

# Service Manual

**PIONEER**  
The Art of Entertainment

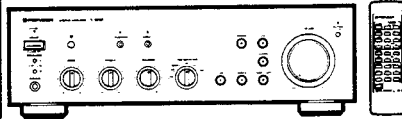

ORDER NO.  
ARP2739

STEREO AMPLIFIER

# A-502R

## A-502R-G

## A-402R

A-502R, A-502R-G AND A-402R HAVE THE FOLLOWING :

Type	Model			Power Requirement	Remarks
	A-502R	A-502R-G	A-402R		
HEWZ	○	-	○	AC 220 V-230 V, 240 V (switchable)*	
HE	○	-	○		
HB	○	-	-		
HEZ	-	○	-		

\* Change the connection of the power transformer's primary wiring.

- This manual is applicable to the following : A-502R/HEWZ, HB, HE; A-502R-G/HEZ; A-402R/HEWZ, HE.
- For the following: A-502R/HB, HE; A-502R-G/HEZ; A-402R/HE, refer to page 24.

## CONTENTS

1. EXPLODED VIEWS, PACKING AND PARTS LIST	2
2. SCHEMATIC AND PCB CONNECTION DIAGRAMS	6
3. PCB PARTS LIST	20
4. FOR A-502R/HB, HE, A-502R-G/HEZ AND A-402R/HE	24
5. IC INFORMATION	26
6. PANEL FACILITIES	28
7. SPECIFICATIONS	31

**PIONEER ELECTRONIC CORPORATION** 4-1, Meguro 1-Chome, Meguro-ku, Tokyo 153, Japan  
**PIONEER ELECTRONICS SERVICE INC.** P.O. Box 1760, Long Beach, California 90801 U.S.A.  
**PIONEER ELECTRONICS OF CANADA, INC.** 300 Allstate Parkway Markham, Ontario L3R 0P2 Canada  
**PIONEER ELECTRONIC [EUROPE] N.V.** Haven 1087 Keetberglaan 1, 9120 Melsele, Belgium  
**PIONEER ELECTRONICS AUSTRALIA PTY. LTD.** 178-184 Boundary Road, Braeside, Victoria 3195, Australia TEL: [03] 580-9911  
 © PIONEER ELECTRONIC CORPORATION 1993

FJ MAY 1993 Printed in Japan

# 1. EXPLODED VIEWS, PACKING AND PARTS LIST

**NOTES:**

- Parts marked by "NSP" are generally unavailable because they are not in our Master Spare Parts List.
- The  $\Delta$  mark found on some component parts indicates the importance of the safety factor of the part. Therefore, when replacing, be sure to use parts of identical designation.
- Parts marked by "☉" are not always kept in stock. Their delivery time may be longer than usual or they may be unavailable.

## 1.1 FRONT VIEW AND REAR VIEW

• Part List (For A-502R/HEWZ and A-402R/HEWZ)

Mark No.	Description	Parts No.	Mark No.	Description	Parts No.
	1 Front panel (A-502R)	ANB1548	$\Delta$	35 AC outlet (A-502R)	AKP-502
	1 Front panel (A-402R)	ANB1550	$\Delta$	35 AC outlet (A-402R)	AKP-508
	2 Panel base (PLS)	AMB2135	$\Delta$	36 AC power cord	ADG1049
	3 Rotary knob L (PLS)	AAB1343		37 AC cord stopper	AEC-882
	4 Rotary knob S (PLS)	AAB1349		38 Pin jack with plug	AKM1061
	5 Power button (PLS)	AAD2421		39 Binder	AEP-215
	6 Screw	ABA1048	$\Delta$	40 Power transformer (A-502R)	ATS1492
	7 LED lens (ABS)	PNW2019	$\Delta$	40 Power transformer (A-402R)	ATS1493
	8 Nut	NK90FUC		41 Screw	ABA1054
	9 LED lens (PLS)	AAK2459		42 TRANS ass'y	AWZ4945
	10 Nut	ABN-065	NSP	43 PC support	AEC1286
	11 Remote sensor	AAK2457		44 INPUT ass'y (A-502R)	AWZ4952
	12 Screw	ABA1011		44 INPUT ass'y (A-402R)	AWZ4955
	13 Screw	VMZ30P060FCU		45 Heat sink (A-502R)	ANH1428
	14 Name plate (MET)	AAM1058		45 Heat sink (A-402R)	ANH1266
	15 Push button (PLS)	AAD2423		46 Screw	ABA1082
	16 SP switch ass'y (A-502R)	AWZ4944	$\Delta$	47 Transistor (Q1, Q2) (A-502R)	2SC3281
	16 SP switch ass'y (A-402R)	AWZ4948	$\Delta$	47 Transistor (Q1, Q2) (A-402R)	2SC3181N
	17 Screw	ABA-298	$\Delta$	48 Transistor (Q3, Q4) (A-502R)	2SA1302
	18 Motor VOL ass'y (A-502R)	AWZ4953	$\Delta$	48 Transistor (Q3, Q4) (A-402R)	2SA1264N
	18 Motor VOL ass'y (A-402R)	AWZ4956		49 Sheet	AEE1014
	19 Nylon rivet	AEC1160	50	.....	
	20 Insulator ass'y	AMR2140		51 Chamber plate (A-502R)	ANG1820
NSP	21 Chassis	ANA1110	NSP	52 Wire clip (A-502R)	AEC1388
	22 VOL board holder plate	ANG1821	NSP	53 Binder (A-502R)	AEF1004
NSP	23 PCB support	AEC1215		54 Holder (A-502R)	ANG1839
NSP	24 PCB support	AEC1232	NSP	55 Tape (A-502R)	AEH1005
NSP	25 PCB support	AEC1231	56	.....	
NSP	26 PCB support	AEC1216		57 Bonnet case	ANE1438
NSP	27 Barrier	AEC1241		58 Function button	AAD2422
NSP	28 Shield ass'y	AWZ4954		59 Screw	BPZ30P080FMC
$\Delta$	29 Fuse (FU2, T500mA) (A-502R)	AEK-505		60 CONTROL ass'y (A-502R)	AWZ4943
$\Delta$	30 Fuse (FU1, T1.6A) (A-402R)	AEK-510		60 CONTROL ass'y (A-402R)	AWZ4947
$\Delta$	30 Fuse (FU1, T2A) (A-502R)	AEK-511		61 Washer	ABE1018
NSP	31 Fuse card (A-502R)	AAX1581		62 Screw	ABA1050
	32 AF ass'y (A-502R)	AWZ4942		63 Screw	ABA1193
	32 AF ass'y (A-402R)	AWZ4946		64 Screw	ABA1192
	33 Rear panel (A-502R)	ANC2074		65 Heat sink holder A	ANG1818
	33 Rear panel (A-402R)	ANC2076		66 Heat sink holder B	ANG1819
NSP	34 Terminal screw	AKE-031		67 Transistor cover LL	ANG1840
				68 Screw	BBZ30P060FZK
				69 PVC washer	ABF1030
				70 Foot	AEC1531
			NSP	71 Spacer	AEB1254

**NOTE:** Screws adjacent to  $\nabla$  mark on product are used for disassembly.

Front view

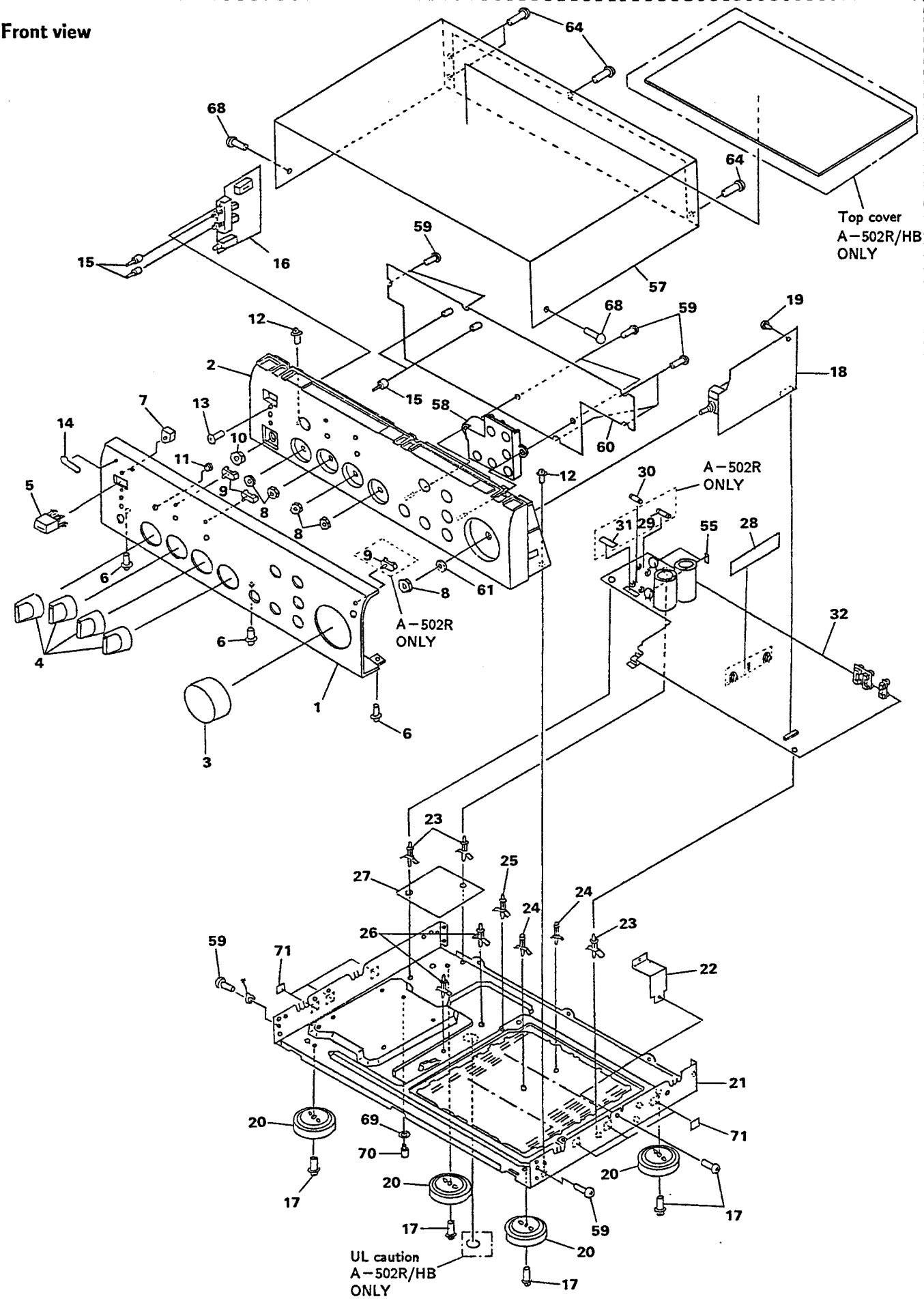

Rear view

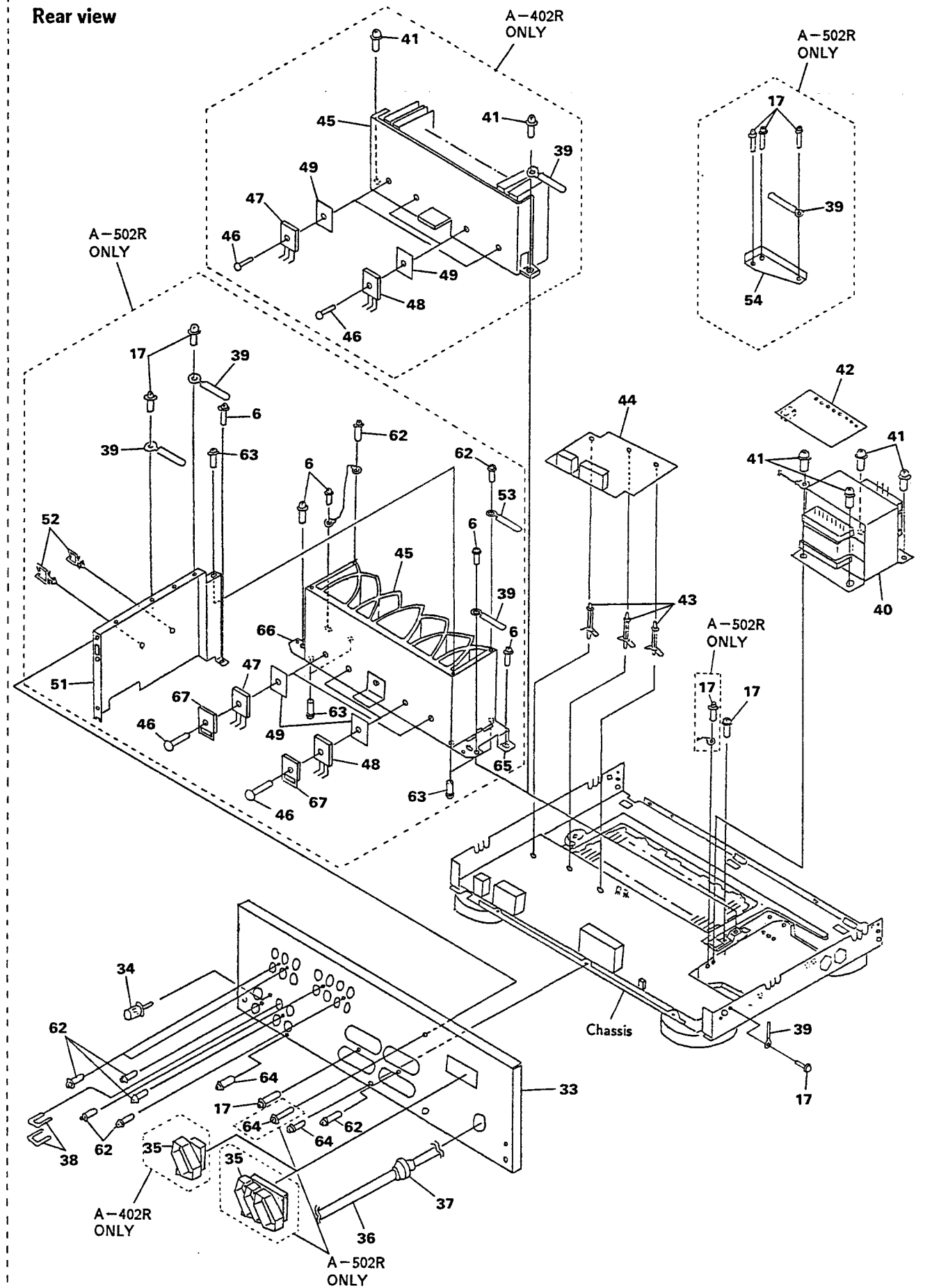

1.2 PACK

Mark No. D

- 1 Fr
- 2 Ra
- 3 Pa
- 3 Pa
- 4 Op
- 5 Pa
- 6 Ra
- 6 Ra
- 7 Ba
- NSP
- 8 Ba

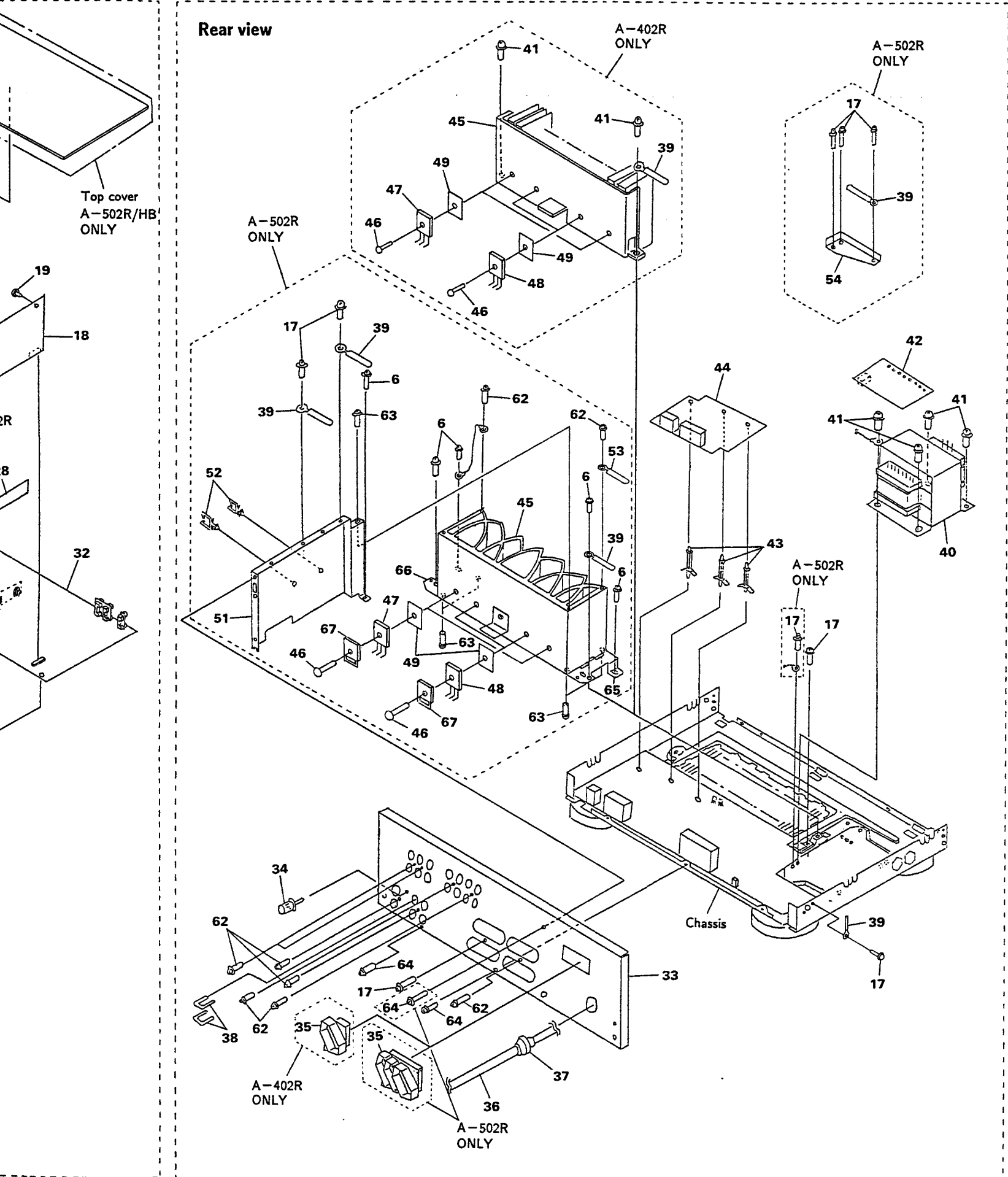

### 1.2 PACKING (For A-502R/HEWZ and A-402R/HEWZ)

Mark No.	Description	Parts No.
1	Front pad	AHA1590
2	Rear pad	AHA1591
3	Packing case (A-502R)	AHD2521
3	Packing case (A-402R)	AHD2523
4	Operating instructions (German)	ARC1416
5	Packing sheet	AHG1016
6	Remote control unit (A-502R)	AXD1354
6	Remote control unit (A-402R)	AXD1343
7	Battery lid	AZA1375
NSP 8	Battery (R03, AAA)	AEX-021

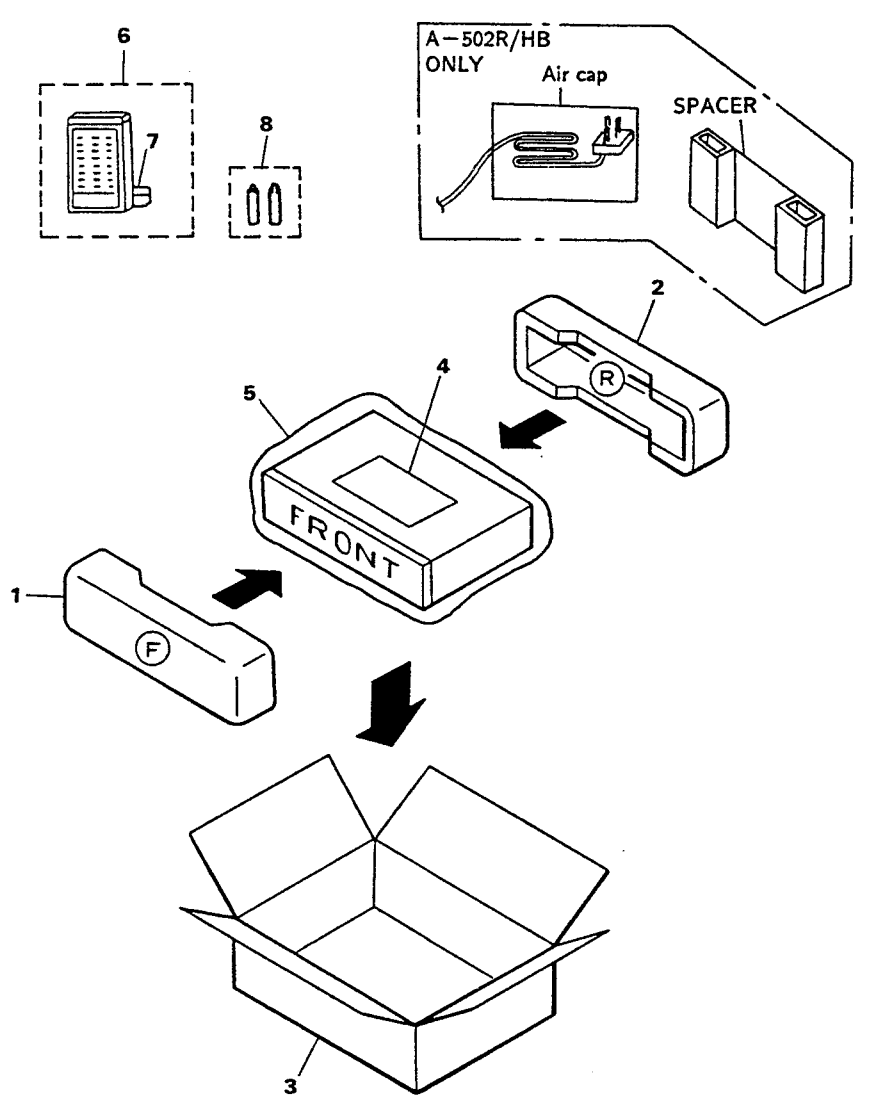

## 2. SCHEMATIC AND PCB CONNECTION DIAGRAMS

### 2.1 OVERALL WIRING DIAGRAM, AF, CONTROL, SP SWITCH AND SHIELD ASSEMBLIES

AF ASS'Y (AWZ4942: A-502R/HEWZ, A-502R/HE AND A-502R-G/HEZ)  
 (AWZ4949: A-502R/HB)  
 (AWZ4946: A-402R/HEWZ AND A-402R/HE)

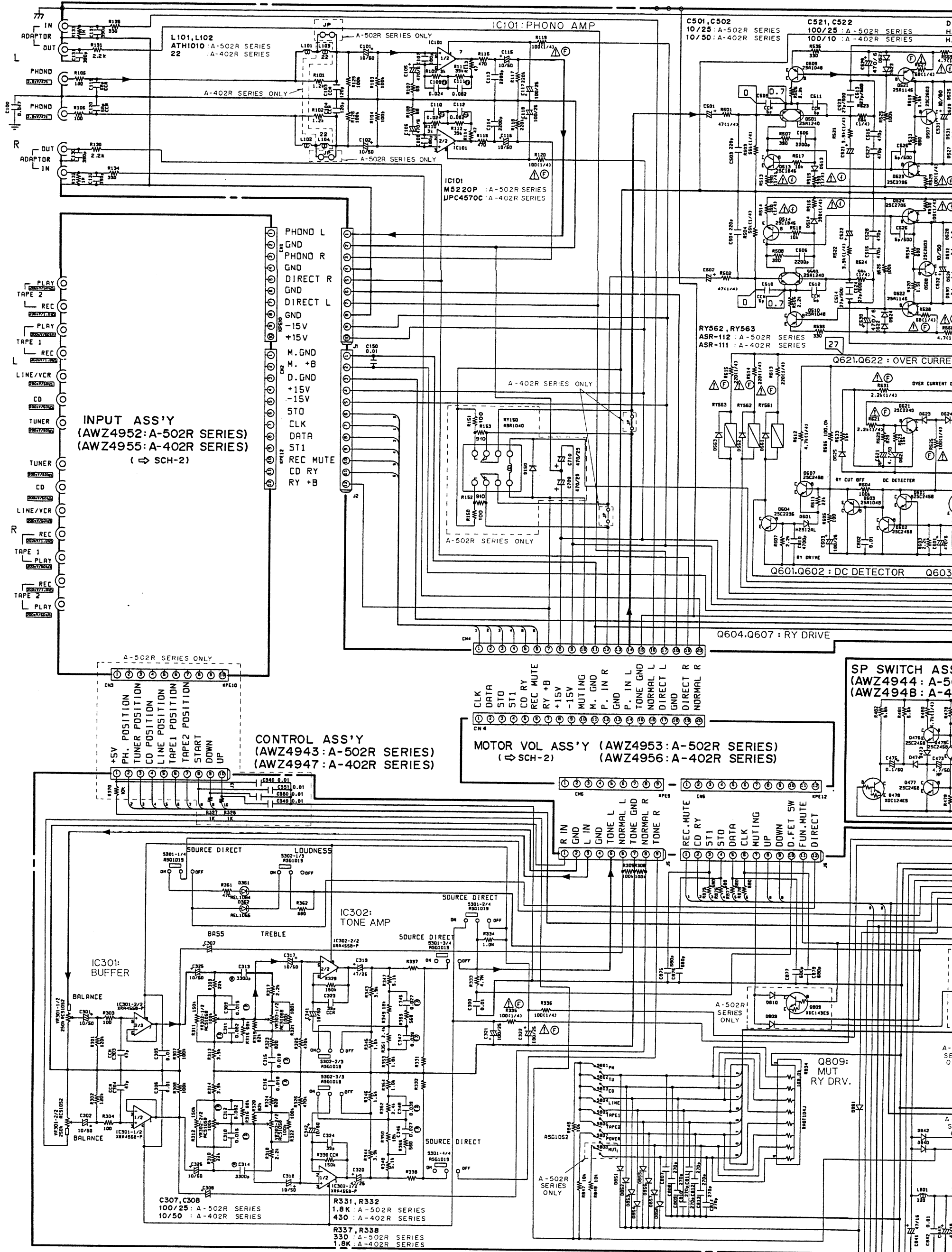

**SCH-1** OVER ALL, AF, CONTROL, SP SWITCH, SHIELD ASSY

RESISTORS Indicated in  $\Omega$ ,  $1/10W$ ,  $\pm 5\%$  unless otherwise noted p:  $\mu F$  tolerance unless otherwise noted k:K, M: M  
 CAPACITORS Indication without Voltage is 50V  
 DIODES Other diodes (not noted) are 1SS252

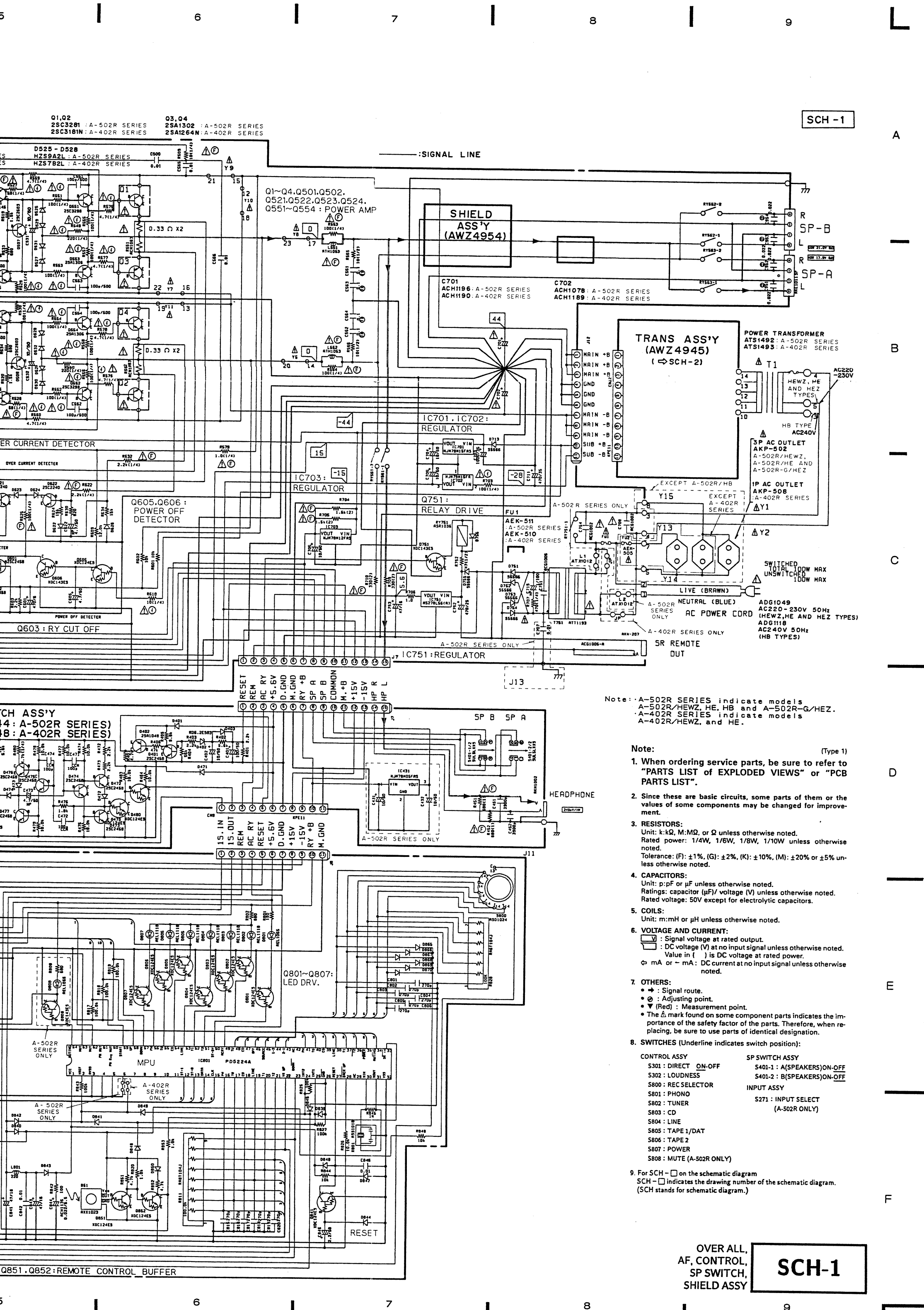

SCH - 1

Note: A-502R SERIES indicate models A-502R/HEWZ, HE, HB and A-502R-G/HEZ. A-402R SERIES indicate models A-402R/HEWZ, and HE.

- Note: (Type 1)
- When ordering service parts, be sure to refer to "PARTS LIST of EXPLODED VIEWS" or "PCB PARTS LIST".
  - Since these are basic circuits, some parts of them or the values of some components may be changed for improvement.
  - RESISTORS:**  
Unit: k: kΩ, M: MΩ, or Ω unless otherwise noted.  
Rated power: 1/4W, 1/6W, 1/8W, 1/10W unless otherwise noted.  
Tolerance: (F): ±1%, (G): ±2%, (K): ±10%, (M): ±20% or ±5% unless otherwise noted.
  - CAPACITORS:**  
Unit: p: pF or μF unless otherwise noted.  
Ratings: capacitor (μF)/ voltage (V) unless otherwise noted.  
Rated voltage: 50V except for electrolytic capacitors.
  - COILS:**  
Unit: m: mH or μH unless otherwise noted.
  - VOLTAGE AND CURRENT:**  
V: Signal voltage at rated output.  
DC: DC voltage (V) at no input signal unless otherwise noted.  
Value in ( ) is DC voltage at rated power.  
mA or -mA: DC current at no input signal unless otherwise noted.
  - OTHERS:**  
→: Signal route.  
⊙: Adjusting point.  
▼ (Red): Measurement point.  
The Δ mark found on some component parts indicates the importance of the safety factor of the parts. Therefore, when replacing, be sure to use parts of identical designation.
  - SWITCHES (Underline indicates switch position):**

<b>CONTROL ASSY</b>	<b>SP SWITCH ASSY</b>
S301: DIRECT ON-OFF	S401-1: A(SPEAKERS)ON-OFF
S302: LOUDNESS	S401-2: B(SPEAKERS)ON-OFF
S800: REC SELECTOR	<b>INPUT ASSY</b>
S801: PHONO	S271: INPUT SELECT
S802: TUNER	(A-502R ONLY)
S803: CD	
S804: LINE	
S805: TAPE 1/DAT	
S806: TAPE 2	
S807: POWER	
S808: MUTE (A-502R ONLY)	

9. For SCH - □ on the schematic diagram  
SCH - □ indicates the drawing number of the schematic diagram.  
(SCH stands for schematic diagram.)

OVER ALL,  
AF, CONTROL,  
SP SWITCH,  
SHIELD ASSY

**SCH-1**



This P.C.B. connection diagram is viewed from the parts mounted side.

HEWZ, A-502R/HE AND A-502R-G/HEZ)  
 B)  
 HEWZ AND A-402/HE)

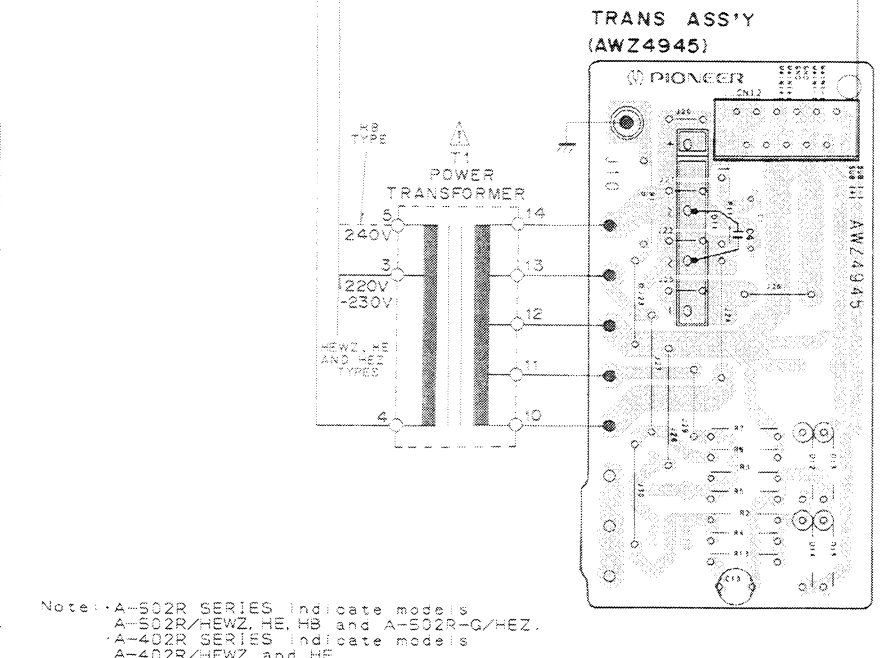
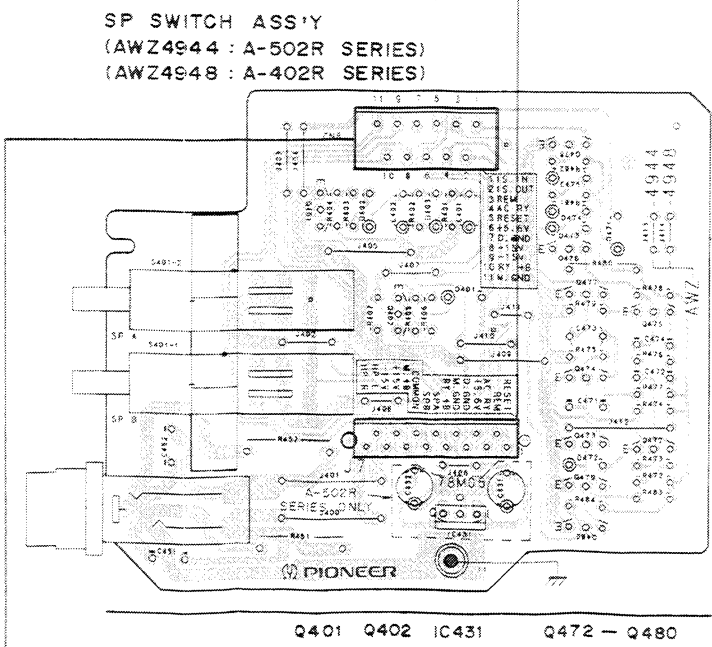
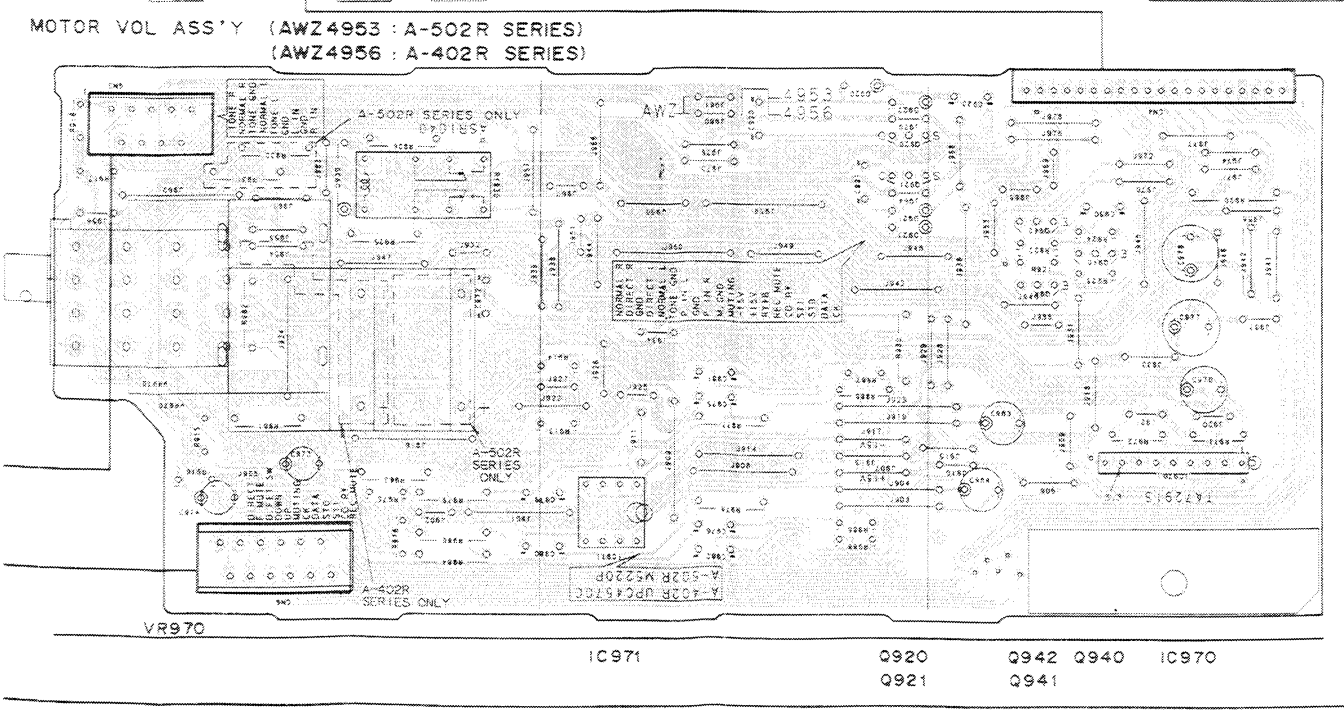
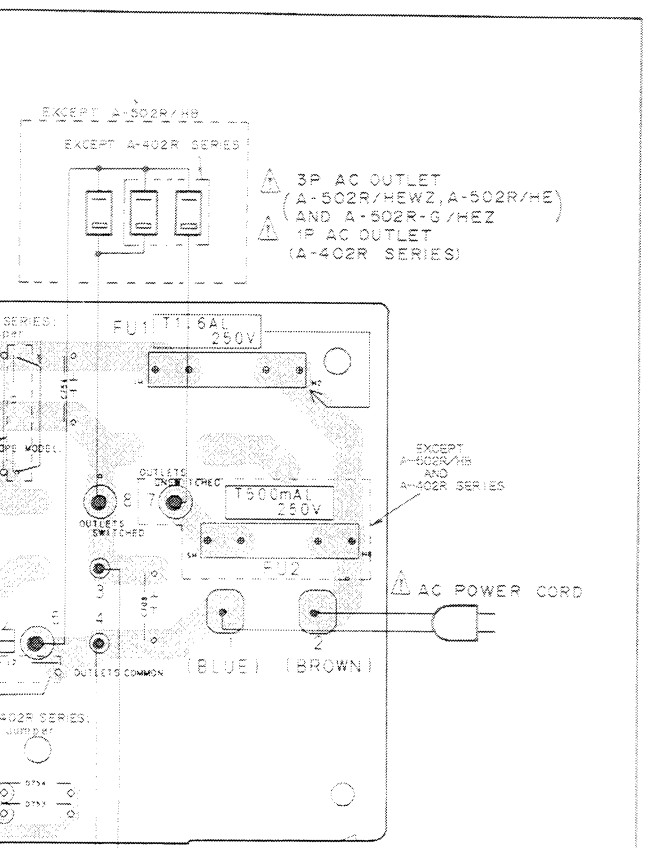
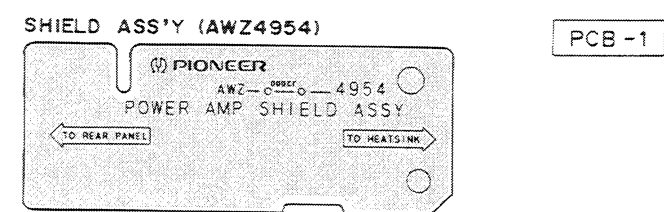
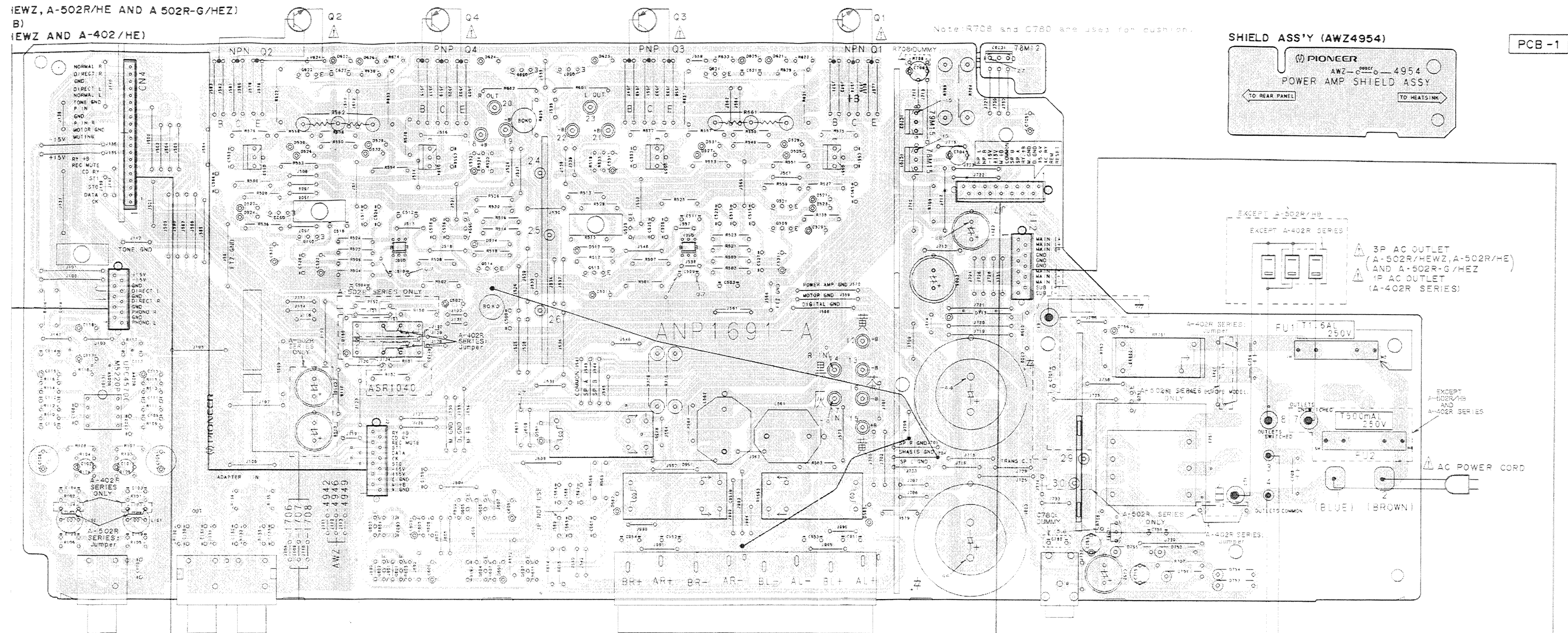

Note: A-502R SERIES indicate models A-502R/HEWZ, HE, HEZ and A-502R-G/HEZ.  
 A-402R SERIES indicate models A-402R/HEWZ, and HE.

NOTE

1. This P.C.B. connection diagram is viewed from the parts mounted side.
2. The parts which have been mounted on the board can be replaced with those shown with the corresponding wiring symbols listed in the following Table

P.C.B. pattern diagram indication	Corresponding part symbol	Part Name
		Transistor
		Radiator type transistor
		Diode
		Resistor
		Capacitor (Polarity)
		Capacitor (Non-polarity)

Others

P.C.B. pattern diagram indication	Part Name
IC	IC
S	Switch
RY	Relay
L	Coil
F	Filter
VR	Variable resistor or Semi fixed resistor

3. The capacitor terminal marked with ⊖ (double circles) shows negative terminal.
4. The diode terminal marked with ⊕ (double circles) shows cathode side.
5. The transistor terminal to which E is affixed shows the emitter.

Line Voltage Selection

Line Voltage can be changed as follows :

1. Disconnect the AC power cord.
2. Remove the top cover.
3. Change the connection of the power transformer primary taps.
4. Stick the line voltage label on the rear panel.

Part No.	Description
AAX-193	220 V label
AAX-192	240 V label

CONTROL ASS'Y (AWZ4943 : A-502R SERIES)  
(AWZ4947 : A-402R SERIES)

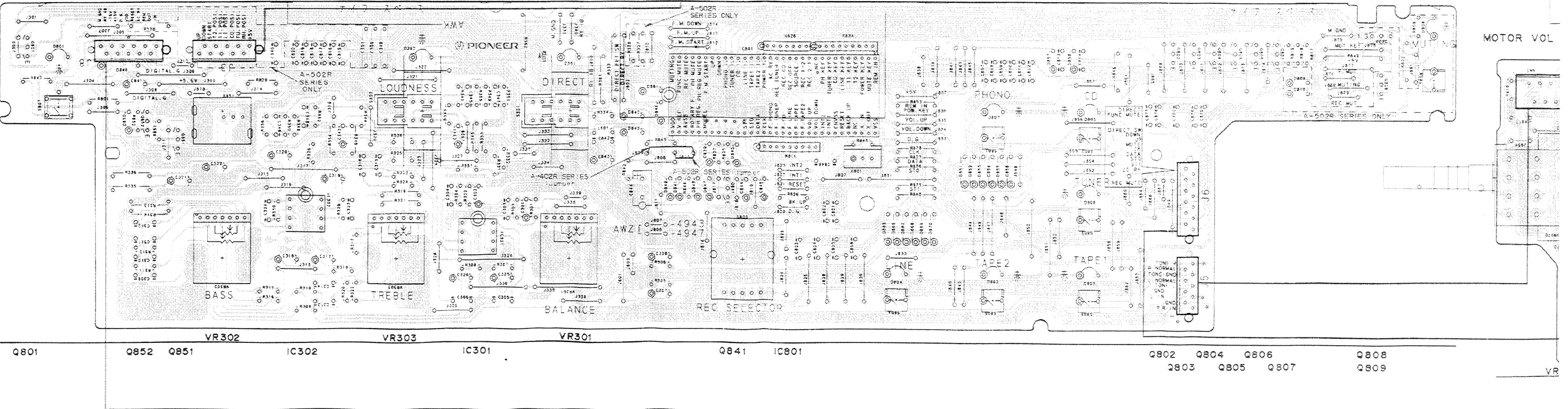

INPUT ASS'Y  
(AWZ4952 : A-502R SERIES)  
(AWZ4955 : A-402R SERIES)

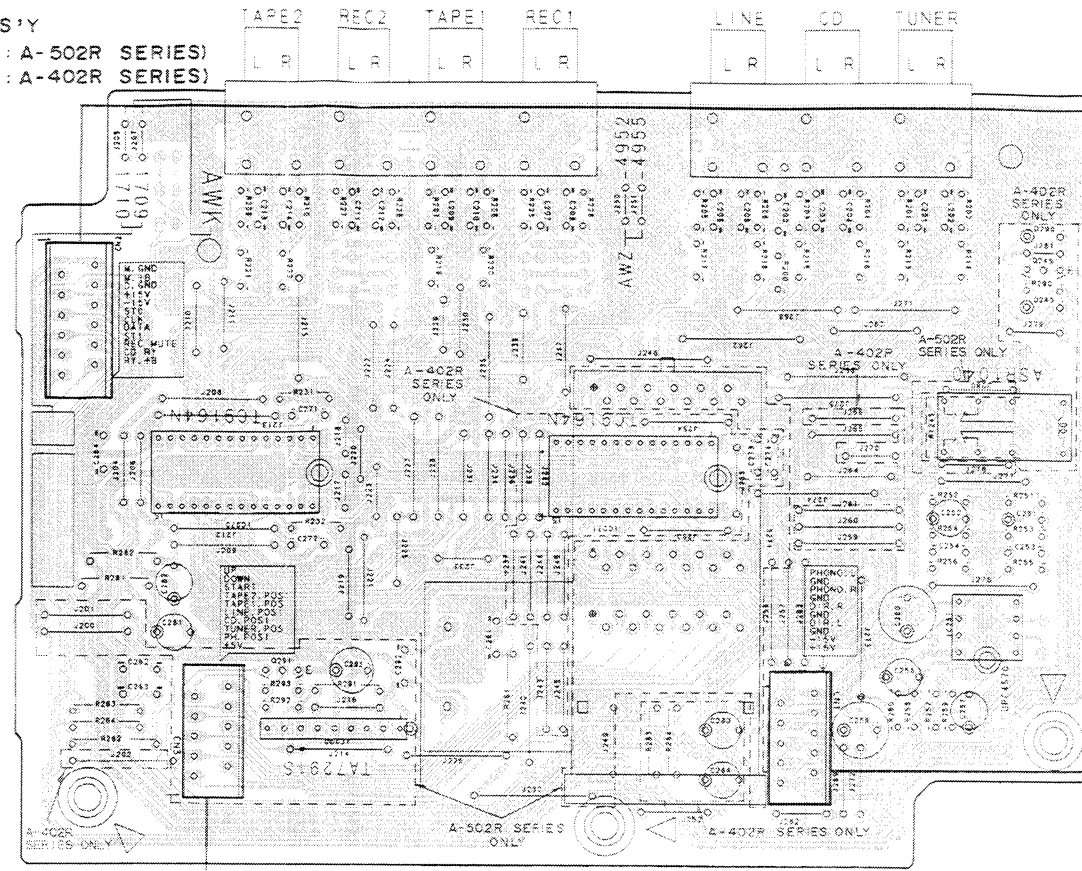

AF ASS'Y  
(AWZ4942 : A-502R/HEWZ, A-502R/  
(AWZ4949 : A-502R/HB)  
(AWZ4946 : A-402R/HEWZ AND A-4

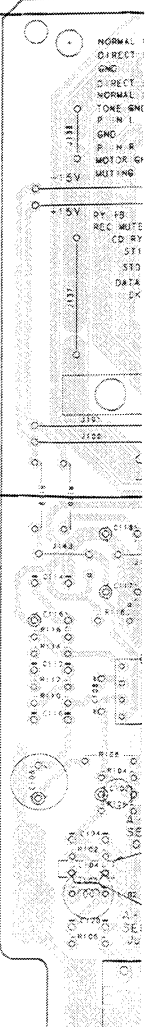
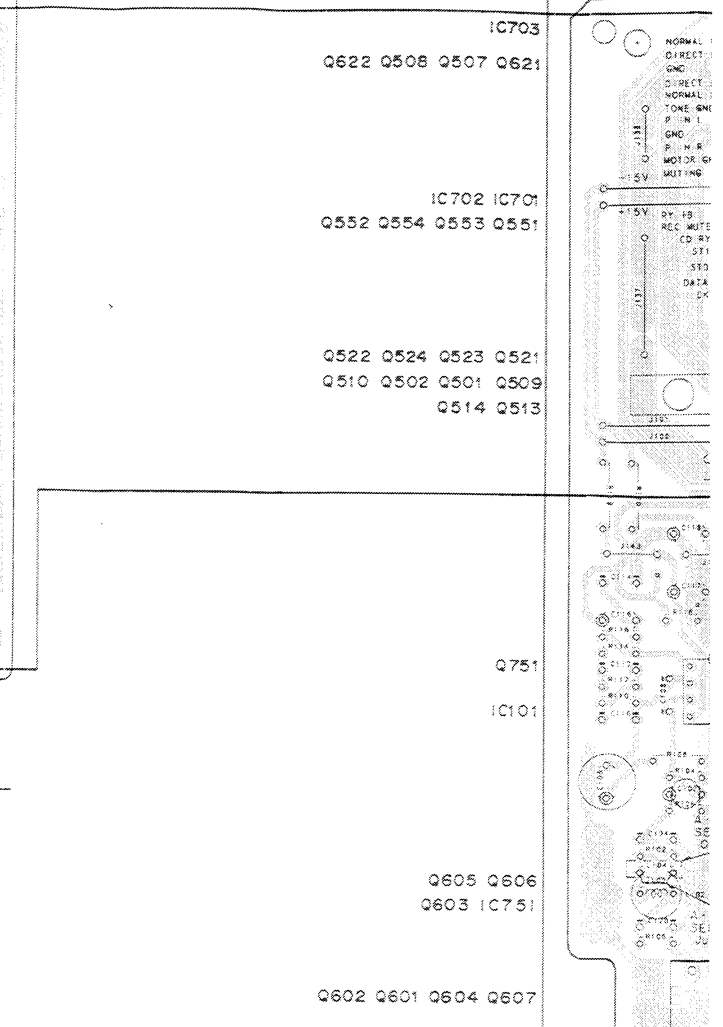

This P.C.B. connection diagram is viewed from the foil side.

HEWZ AND A-402R (HEZ)  
HEWZ, A-202RHE AND A-202R-G (HEZ)

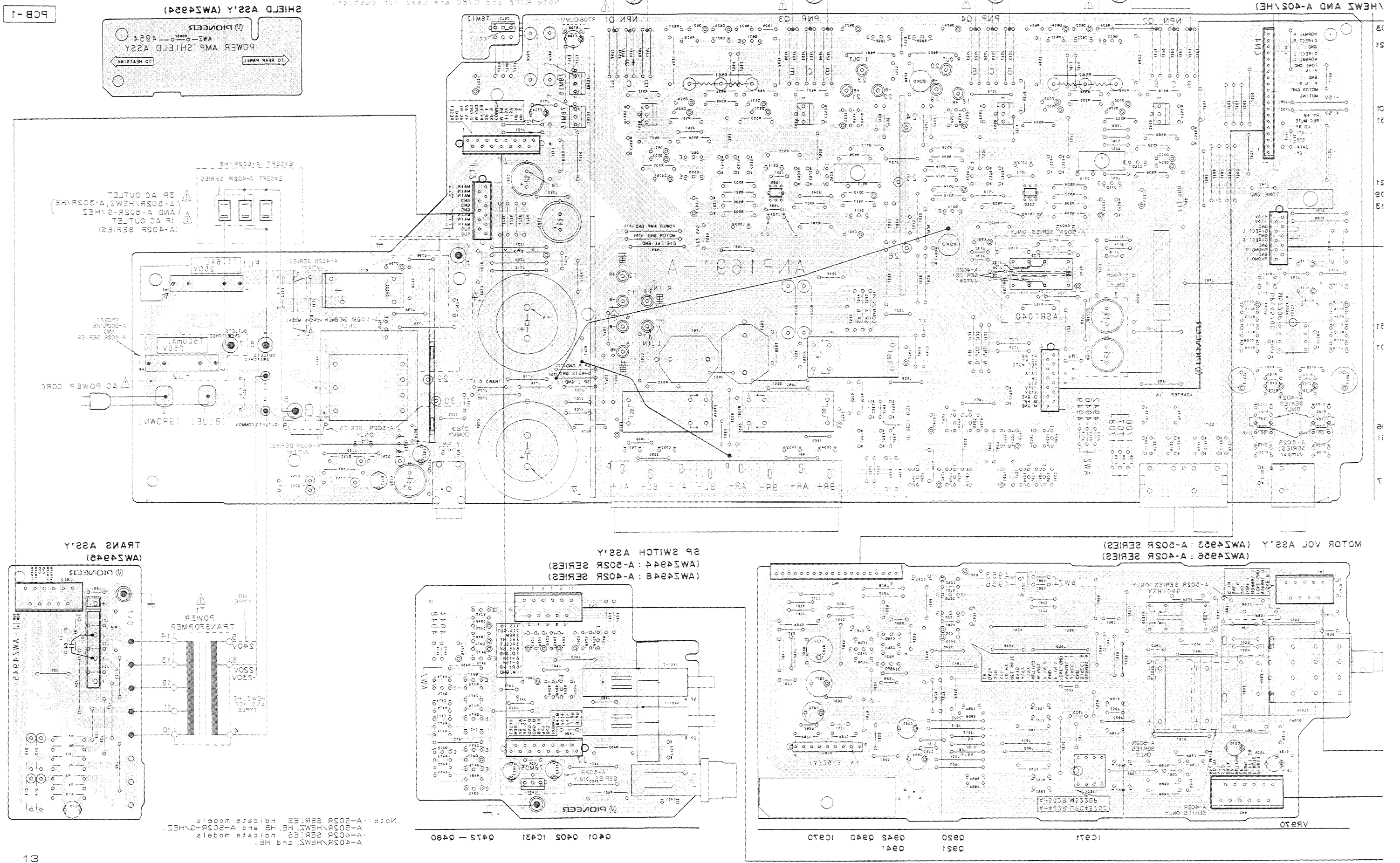

A

B

C

D

10

11

12

13

14

15

16

17

18

19

20

21

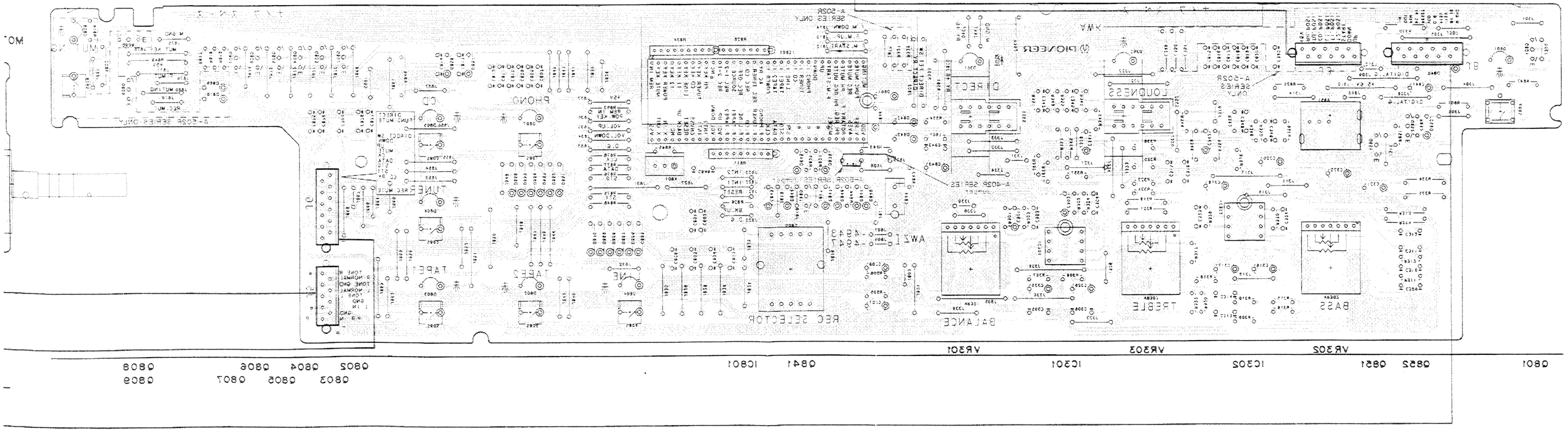

0801 0825 0821 IC305 VR305 VR303 VR301  
 0802 0803 0802 0801 0805 0804 0808  
 0808 0808

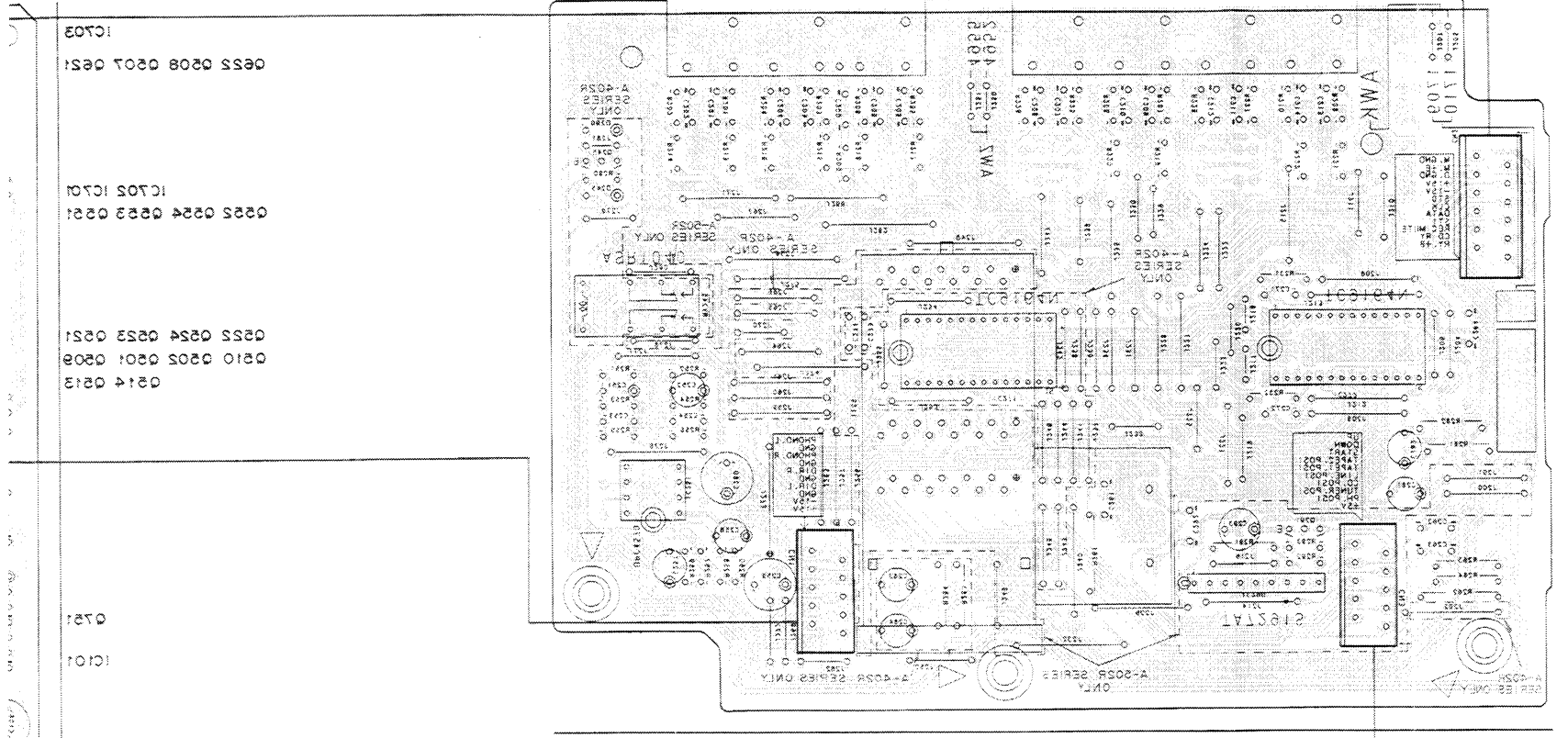

0241 IC580 IC575 IC521 IC521 0248  
 0281 IC101 0281

0214 0213 0210 0205 0201 0208 0253 0254 0253 0251

0253 0254 0253 0251 IC205 IC201

0253 0208 0207 0251 IC203

(AW24955 : A-40SR SERIES)  
 (AW24952 : A-20SR SERIES)  
 (AW24949 : A-20SR/HBW)  
 (AW24946 : A-40SR/HBW)  
 AF ASS'Y

### 2.2 INPUT, MOTOR VOL AND TRANS ASSEMBLIES

A

B

C

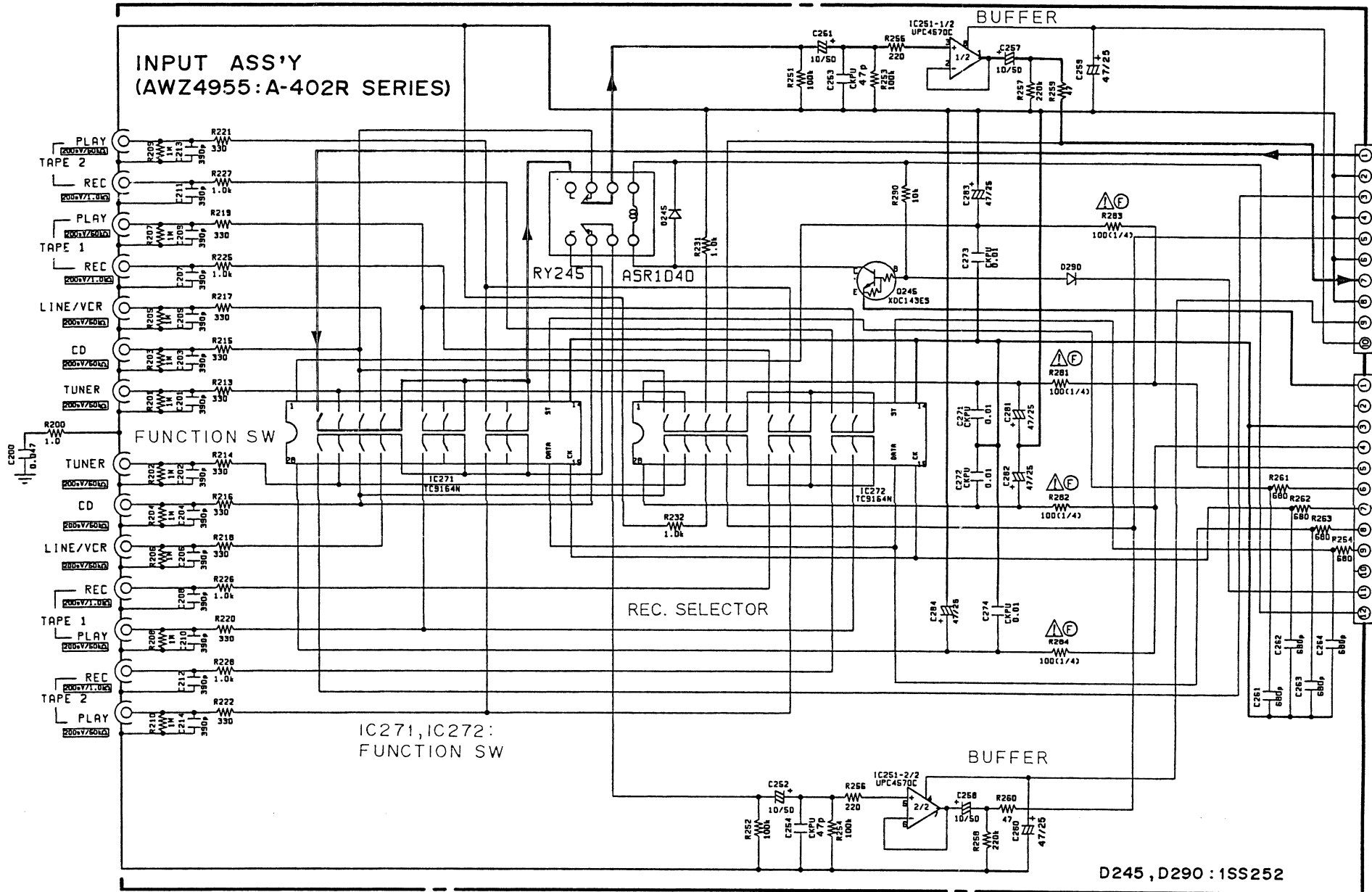

D

E

F

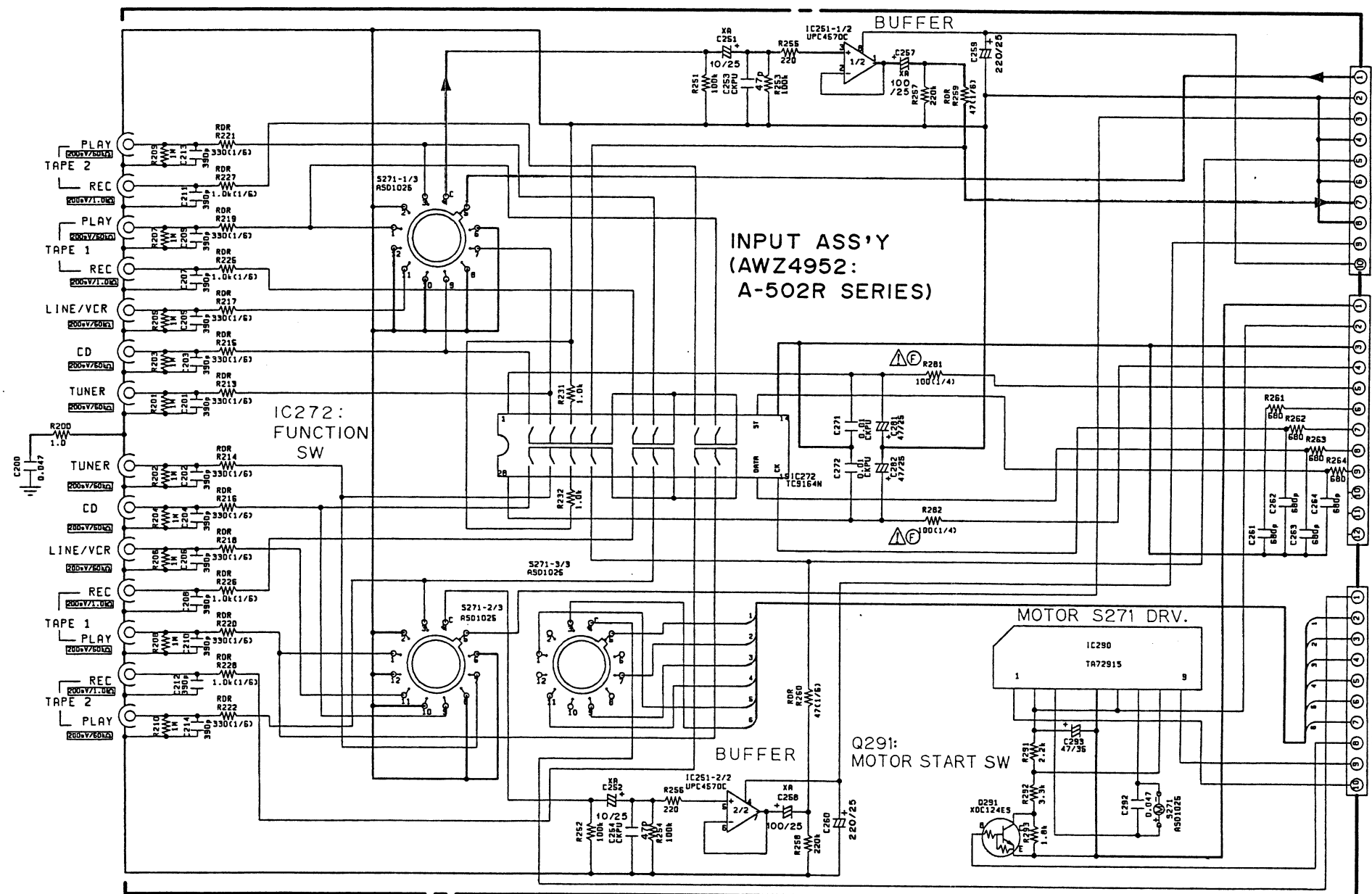

**SCH-2** INPUT, MOTOR VOL, TRANS ASSY

PHONO L  
GND  
PHONO R  
GND  
DIRECT R  
GND  
DIRECT L  
GND  
-15V  
+15V

TO AF ASS'Y J1  
(SCH-1)

M.GND  
M.+B  
D.GND  
+15V  
-15V  
STO  
CLK  
DATA  
ST1  
REC MUTE  
CD RY  
RY +B

TO AF ASS'Y J2  
(SCH-1)

CLK  
DATA  
STO  
ST1  
CD RY  
REC MUTE  
RY +B  
+15V  
-15V  
MUTING  
M.GND  
POWER IN R  
GND  
POWER IN L  
TONE GND  
NORMAL L  
DIRECT L  
GND  
DIRECT R  
NORMAL R

TO AF ASS'Y CN4 (SCH-1)

PHONO L  
GND  
PHONO R  
GND  
DIRECT R  
GND  
DIRECT L  
GND  
-15V  
+15V

TO AF ASS'Y J1  
(SCH-1)

M.GND  
M.+B  
D.GND  
+15V  
-15V  
STO  
CLK  
DATA  
ST1  
REC MUTE  
CD RY  
RY +B

TO AF ASS'Y J2  
(SCH-1)

+5V  
PH.POSITION  
TUNER POSITION  
CD POSITION  
TAPE1 POSITION  
TAPE2 POSITION  
START  
DOWN  
UP

TO CONTROL ASS'Y J3  
(SCH-1)

REC MUTE  
CD RY  
ST1  
STO  
DATA  
CLK  
MUTING  
UP  
DOWN  
D.FET SW  
F.MUTE  
DIRECT

TO CONTROL ASS'Y J6 (SCH-1)

TONE R  
NORMAL R  
TONE GND  
NORMAL L  
TONE L  
GND  
L IN  
GND  
R IN

TO CONTROL ASS'Y J5 (SCH-1)

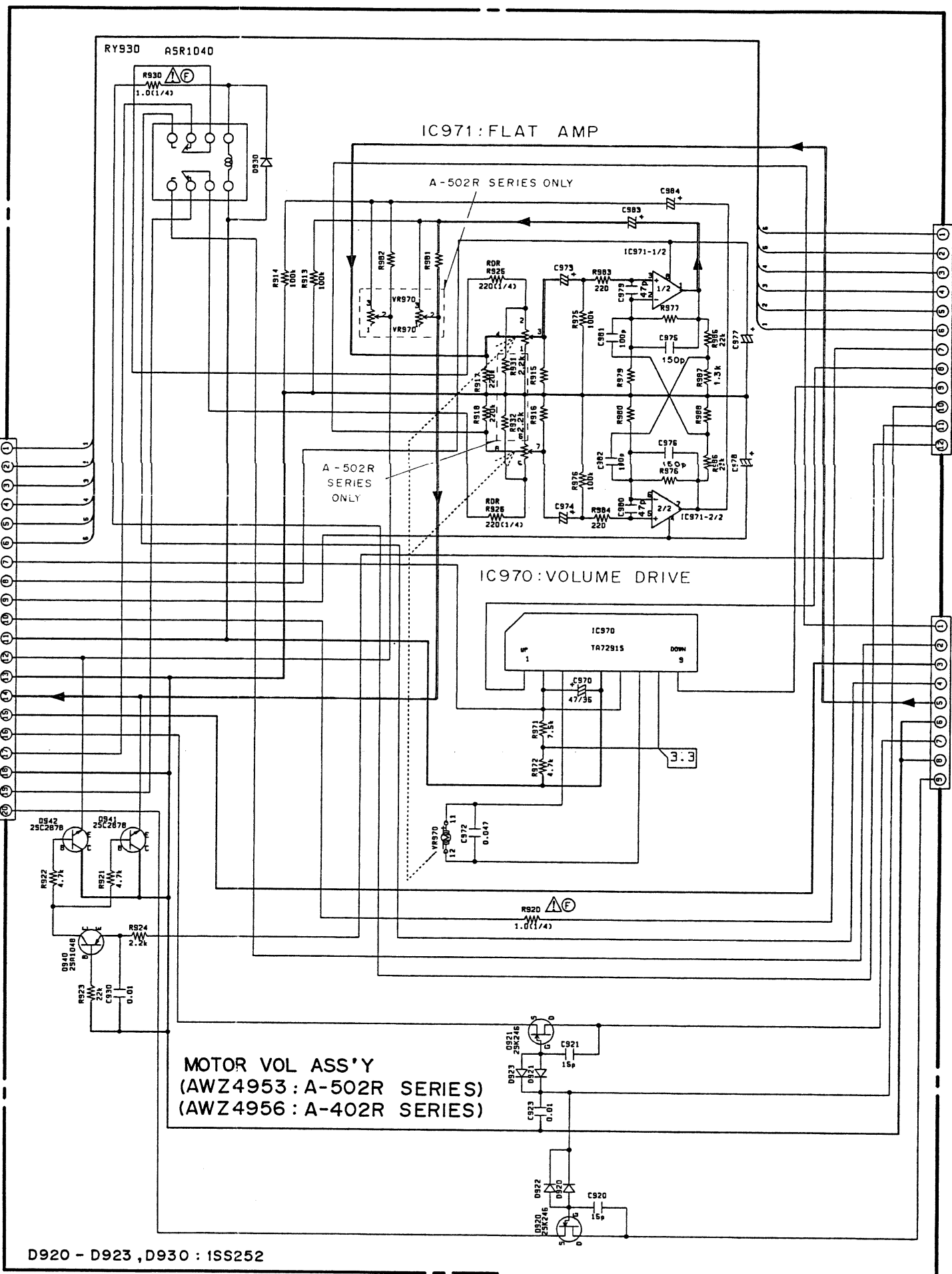

D920 - D923, D930 : 1SS252

	A-502R SERIES	A-402R SERIES
C973, C974	10/25	10/50
C977, C978	220/25	10/50
C983, C984	100/25	10/50
IC971	MS220P	UPC4570C
R915, R916	8.2K	100K
R977, R978	2.7K	2.2K
R979, R980	390	430
R981, R982	3.3K	1K
R988	910	2.2K
VR970	ACX1083	ACX1084

Note: A-502R SERIES indicate models A-502R/HEWZ, HE, HB and A-502R-G/HEZ. A-402R SERIES indicate models A-402R/HEWZ, and HE.

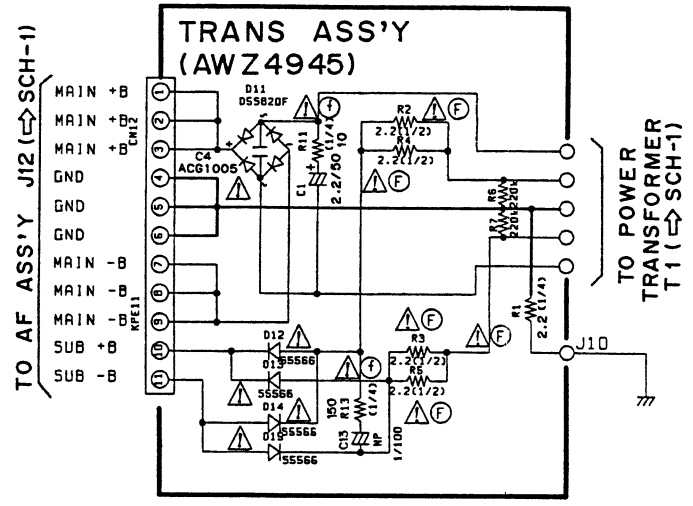

TO POWER TRANSFORMER T1 (SCH-1)

TO AF ASS'Y J12 (SCH-1)

—: SIGNAL LINE

INPUT MOTOR VOL, TRANS ASSY



Mark No.	Description	Parts No.
C509-C512 C103,C104 C119,C120 C715 C621,C622	CCCSL050C500 CCMSL121J50 CCMSL680J50 CEANP010M100 CEANP4R7M50	
C501,C502 (A-402R) C101,C102,C115,C116,C531,C532, C704-C706 C521,C522 (A-402R) C117,C118,C603	CEAS100M50 CEAS100M50 CEAS101M10 CEAS101M25	
C703 C753 C709,C710 (A-502R only) C752 C711	CEAS102M35 CEAS470M16 CEAS471M25 CEAS471M25 CEAS471M35	
C105,C106,C529,C530,C601 C605 C501,C502 (A-502R) C521,C522 (A-502R) C561-C564	CEAS471M6 CEAS4R7M50 CEEA100M50 CEEA101M25 CFTXA104J50	
C951-C954 C109,C110 C111,C112 C113,C114 C515,C516,C527,C528	CFTYA223J50 CFTXA243J50 CFTXA823J50 CKCYB222K50 CKCYB471K50	
C505,C506 C610 C707 (A-502R only) C150,C500,C565,C566,C602 C100	CKCYB222K500 CKCYB472K50 CKCYF103Z50 CKCYF103Z50 CKCYF473Z50	
C107,C108 C130-C133	CKMYB181K50 CKCYB391K500	
<b>RESISTORS</b>		
△ R561,R562 (0.33, 5W) R752	ACN1063 RD1/2PM470J	
△ R565,R566 R612	RD1/2PMF100J RD1/4PM472J	
△ R579	RD1/4PMF010J	
△ R509	RD1/4PMF100J	
△ R119,R120,R563,R564,R625	RD1/4PMF101J	
△ R613-R615	RD1/4PMF221J	
△ R621,R622,R631,R632	RD1/4PMF222J	
△ R527,R528	RD1/4PMF680J	
R150,R151 (A-502R only) R521,R522 R501,R502 R503,R504,R523,R524 R152,R153 (A-502R only)	RD1/4PM101J RD1/4PM392J RD1/4PM470J RD1/4PM563J RD1/4PM911J	
△ R610	RFA1/4PS100J	
△ R529,R530,R551-R558,R703	RFA1/4PS101J	
△ R549,R550	RFA1/4PS221J	
△ R513-R516	RFA1/4PS391J	
△ R707	RFA1/4PS471J	
△ R559,R560,R575-R578	RFA1/4PS4R7J	
△ R704,R705	RS2LMF152J	
△ R709,R710	RS2LMF331J	
Other Resistors	RD1/8PM□□□J	

Mark No.	Description	Parts No.
<b>OTHERS</b>		
PIN JACK(2P) PIN JACK(4P) SPEAKER TERMINAL 8-P JACK	AKB1100 AKB1124 AKE1011 AKN-207	
<b>CONTROL ASS'Y</b>		
<b>SEMICONDUCTORS</b>		
IC801 IC301,IC302 Q801-Q807,Q841,Q851,Q852 Q808,Q809 (A-502R only) D809,D810 (A-502R only)	PD5224A XRA4558-P XDC124ES XDC143ES 1SS252	
D839-D858,D861,D865-D870 D808 (A-502R only) D362,D801 D361 D802-D807	1SS252 AEL1065 AEL1065 AEL1084 AEL1118	
<b>SWITCHES</b>		
S800 S301,S302 S801-S806 S808 (A-502R only) S807	ASD1024 ASG1019 ASG1034 ASG1034 ASG1052	
<b>COIL</b>		
L801	LAU221K	
<b>CAPACITORS</b>		
C844 C323,C324 C303,C304 C307,C308 (A-401R) C301,C302,C317,C318,C325,C326, C341,C342	ACH1135 CCMSL390J50 CCMSL470J50 CEAS100M50 CEAS100M50	
C307,C308 (A-502R) C321,C322 C845 C841,C843 C319,C320	CEAS101M25 CEAS101M25 CEAS2R2M50 CEAS470M16 CEAS470M25	
C309,C310 C315,C316 C345,C346 C347,C348 C311,C312	CFTYA153J50 CFTYA183J50 CFTYA273J50 CFTYA393J50 CFTYA823J50	
C340 (A-502R only) C300,C305,C306,C842,C846 C801-C820 C875-C878 C349-C351 C313,C314	CKCYF103Z50 CKCYF103Z50 CKMYB271K50 CKMYB681K50 CKPUYF103Z25 CQMA332J50	
<b>RESISTORS</b>		
VR301 VR302,VR303 R828 (100K) R811,R834 R335,R336	ACS1052 ACS1058 RA6T104J RA8T104J RD1/4PMF101J	
Other Resistors	RD1/8PM□□□J	

Mark No.	Description	Parts No.
<b>OTHERS</b>		
851 X801	REMOTE RECEIVER UNIT CERAMIC RESONATOR (4.19MHz)	AXX1023 ASS1018
<b>SP SWITCH ASS'Y</b>		
<b>SEMICONDUCTORS</b>		
IC431 (A-502R only) Q402 Q401,Q472-Q477 Q478-Q480 D401,D403,D471-D474	NJM78M05FAS 2SA1048 2SC2458 XDC124ES 1SS252	
D402	RD6.2ESB3	
<b>SWITCH</b>		
S401	SUL5LXXS	
<b>CAPACITORS</b>		
C471,C472,C474 C473 C475 C402 C431,C432 (A-502R only)	CCMSL101J50 CEANP4R7M50 CEAS0R1M50 CEAS100M50 CEAS100M50	
C401 C451,C452	CEAS101M50 CKCYB392K50	
<b>RESISTORS</b>		
R480 △ R451,R452	RD1/4PM472J RS1PMF681J RD1/8PM□□□J	
Other Resistors		
<b>OTHERS</b>		
CN8	JACK CONNECTOR(11P)	AKN1002 KPE11
<b>SHIELD ASS'Y</b>		
SHIELD ASS'Y has no service part.		
<b>TRANS ASS'Y</b>		
<b>SEMICONDUCTORS</b>		
△ D11 △ D12-D15	D5SB20F S5566	
<b>CAPACITORS</b>		
C13 C1 C4	CEANP010M100 ACH1237 ACG1005	
<b>RESISTORS</b>		
△ R1-R5 △ R11 △ R13	RD1/2PMF2R2J RFA1/4PS100J RFA1/4PS151J RD1/8PM□□□J	
Other Resistors		
<b>OTHERS</b>		
CN12	CONNECTOR(11P)	KPE11

Mark No.	Description	Parts No.
<b>INPUT ASS'Y</b>		
<b>SEMICONDUCTORS</b>		
IC290 (A-502R only) IC271 (A-402R only) IC272 IC251 Q245 (A-402R only)	TA7291S TC9164N TC9164N UPC4570C XDC143ES	
Q291 (A-502R only) D245,D290 (A-402R only)	XDC124ES 1SS252	
<b>SWITCH</b>		
S271 (A-502R only)	ASD1025	
<b>RELAY</b>		
RY245 (A-402R only)	ASR1040	
<b>CAPACITORS</b>		
C253,C254 C251,C252,C257,C258 (A-402R) C259,C260 (A-502R) C259,C260 (A-402R) C281,C282	CCPUSL470J50 CEAS100M50 CEAS221M25 CEAS470M25 CEAS470M25	
C283,C284 (A-402R only) C293 (A-502R only) C251,C252 (A-502R) C257,C258 (A-502R) C200	CEAS470M25 CEAS470M35 CEEA100M50 CEEA101M50 CKCYF473Z50	
C292 (A-502R only) C261-C264 C271,C272 C273,C274 (A-402R only) C201,C202,C205,C206,C209, C210,C213,C214 C203,C204,C207,C208,C211,C212	CKCYX473M25 CKMYB681K50 CKPUYF103Z25 CKPUYF103Z25 CKCYB391K50 CKCYB391K500	
<b>RESISTORS</b>		
△ R281,R282 △ R283,R284 (A-402R only) R225-R228 (A-502R only) R213-R222 (A-502R only) R259,R260 (A-502R only)	RD1/4PMF101J RD1/4PMF101J RDR1/6PU102J RDR1/6PU331J RDR1/6PU470J	
Other Resistors	RD1/8PM□□□J	
<b>OTHERS</b>		
CN1,CN3 CN2	PIN JACK(8P) PIN JACK(6P) CONNECTOR(10P) CONNECTOR(12P)	AKB1127 AKB1138 KPE10 KPE12
<b>MOTOR VOL ASS'Y</b>		
<b>SEMICONDUCTORS</b>		
IC971 (A-502R) IC970 IC971 (A-402R) Q940 Q941,Q942	M5220P TA7291S UPC4570C 2SA1048 2SC2878	
Q920,Q921 D920-D923 D930	2SK246 1SS252 1SS252	

<b>Mark No.</b>	<b>Description</b>	<b>Parts No.</b>
<b>RELAY</b>		
RY930		ASR1040
<b>CAPACITORS</b>		
C981, C982		CCMSL101J50
C920, C921		CCMSL150J50
C979, C980		CCMSL470J50
C973, C974, C977, C978 (A-402R)		CEAS100M50
C977, C978 (A-502R)		CEAS221M25
C970		CEAS470M35
C973, C974 (A-502R)		CEEA100M25
C983, C984 (A-502R)		CEEA101M25
C923, C930		CKCYF103Z50
C972		CKCYX473M25
C975, C976		CKMYB151K50
<b>RESISTORS</b>		
VR970 (A-502R)		ACX1083
VR970 (A-402R)		ACX1084
R981, R982 (A-402R)		RD1/4PM102J
R977, R978 (A-402R)		RD1/4PM222J
R979, R980 (A-402R)		RD1/4PM431J
△ R920		RD1/4PMF010J
△ R930		RD1/4PMF010J
R925, R926		RDR1/4PM221J
R931, R932 (A-502R only)		RDR1/4PM222J
R977, R978 (A-502R)		RDR1/4PM272J
R981, R982 (A-502R)		RDR1/4PM332J
R979, R980 (A-502R)		RDR1/4PM391J
Other Resistors		RD1/8PM□□□J
<b>OTHERS</b>		
CN6	CONNECTOR(12P)	KPE12
CN5	CONNECTOR(9P)	KPE9

## 4. FOR A – 502R/HB, HE, A – 502R – G/HEZ AND A – 402R/HE

**NOTES:**

- Parts marked by "NSP" are generally unavailable because they are not in our Master Spare Parts List.
- The  $\Delta$  mark found on some component parts indicates the importance of the safety factor of the part. Therefore, when replacing, be sure to use parts of identical designation.
- Parts marked by "⊙" are not always kept in stock. Their delivery time may be longer than usual or they may be unavailable.

### 4.1 FOR A – 502R/HB, HE AND A – 502R – G/HEZ

#### CONTRAST OF MISCELLANEOUS PARTS

A – 502R/HB, HE, A – 502R – G/HEZ and A – 502R/HEWZ have the same construction except for the following :

Mark	Symbol & Description	Part No.				Remarks
		A – 502R HEWZ	A – 502R HB	A – 502R HE	A – 502R – G HEZ	
	AF assembly	AWZ4942	AWZ4949	AWZ4942	AWZ4942	
$\Delta$	AC power cord	ADG1049	ADG1118	ADG1049	ADG1049	
$\Delta$	Fuse (FU2 T500mA/250V)	AEK – 505	.....	AEK – 505	AEK – 505	
NSP	Fuse card	AAX1581	.....	AAX1581	AAX1581	
$\Delta$	3P AC outlet	AKP – 502	.....	AKP – 502	AKP – 502	
	Rotary knob L (PLS)	AAB1343	AAB1343	AAB1343	AAB1355	
	Rotary knob S (PLS)	AAB1349	AAB1349	AAB1349	AAB1350	
	Power button (PLS)	AAD2421	AAD2421	AAD2421	AAD2450	
	Function button (PLS)	AAD2422	AAD2422	AAD2422	AAD2451	
	Push button (PLS)	AAD2423	AAD2423	AAD2423	AAD2452	
	PIONEER badge	AAM1058	AAM1058	AAM1058	AAM1059	
	Screw	BBZ30P060FZK	BBZ30P060FZK	BBZ30P060FZK	.....	
	Screw	.....	.....	.....	ABA – 274	See P3. For NO.68
	Spacer	.....	AHB1110	.....	.....	See P5.
	Packing case	AHD2521	AHD2522	AHD2521	AHD2554	
	Air cap	.....	AHG1087	.....	.....	See P5.
	Panel base	AMB2135	AMB2135	AMB2135	AMB2156	
	UL caution	.....	AAX – 313	.....	.....	See P3.
	Top cover (PLS)	.....	AME1086	.....	.....	See P3.
	Front panel	ANB1548	ANB1548	ANB1548	ANB1560	
	Rear panel	ANC2074	ANC2075	ANC2074	ANC2074	
	Bonnet (MET)	ANE1415	ANE1436	ANE1415	ANE1432	
	Remote control	AXD1354	AXD1354	AXD1354	AXD1355	
	Battery cover	AZA1375	AZA1375	AZA1375	AZN2243	
	Operating Instructions (German)	ARC1416	.....	.....	ARC1416	
	Operating Instructions (English)	.....	ARB1422	.....	.....	
	Operating Instructions (English/German/French/ Italian/Swedish/Dutch/ Spanish/Portuguese)	.....	.....	ARE1272	.....	

**AF ASSEMBLY**

Although AWZ4949 and AWZ4942 are different in part number, they have the same service parts.

**4.2 FOR A – 402R/HE**

**CONTRAST OF MISCELLANEOUS PARTS**

**A – 402R/HE and A – 402R/HEWZ have the same construction except for the following :**

Mark	Symbol & Description	Part No.		Remarks
		A – 402R/HEWZ	A – 402R/HE	
	Operating Instructions (German)	ARC1416	.....	
	Operating Instructions (English/German/French/ Italian/Swedish/Dutch/ Spanish/Portuguese)	.....	ARE1272	

## 5. IC INFORMATION

● The information shown in the list is basic information and may not correspond exactly to that shown in the schematic diagrams.

■ **IC801 : (PD5224A)**  
 ● **AMP CONTROL  $\mu$  -COM**

**Pin Assignment**

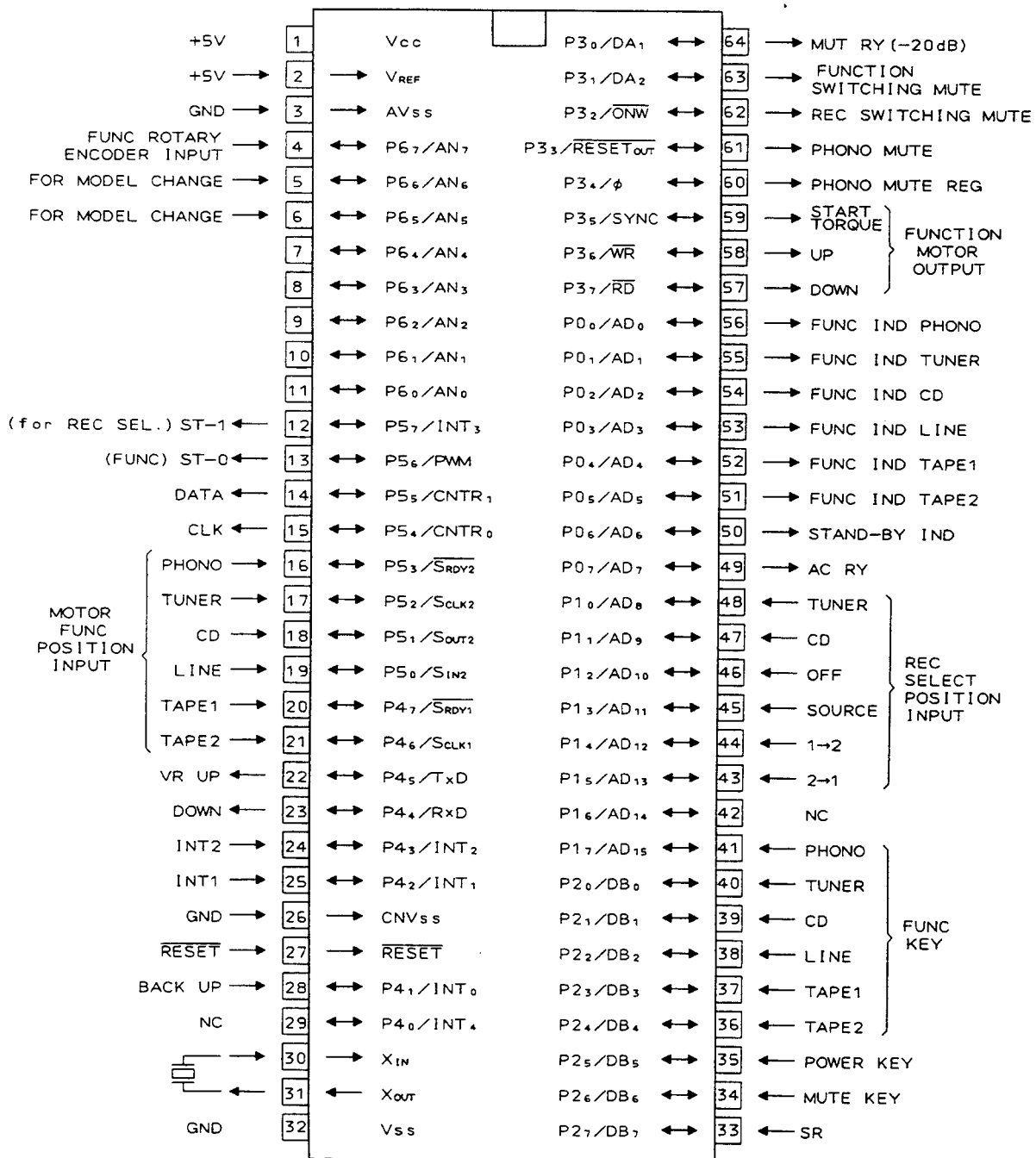

Pin Function

No.	Name	I/O	Function name	Function	Logic
1	V <sub>CC</sub>		V <sub>CC</sub>	Input voltage +5V	-
2	V <sub>REF</sub>	I	-	"H" Pull up	-
3	AV <sub>SS</sub>	I	-	Digital GND	-
4	P67/AN7	I	F-EN	Function Rotary encoder input	Step V input
5	P66/AN6	I		For model change	"H"
6	P65/AN5	I		For model change	"H"
7	P64/AN4				
8	P63/AN3				
9	P62/AN2				
10	P61/AN1				
11	P60/AN0				
12	P57/INT3	O	ST	REC. SEL. SW(TC9164N) ST - 1	
13	P56/PWM	O	ST	FUNCTION REC. SEL. SW(TC9164N) ST - 0	
14	P55/CNTR1	O	DATA	FUNCTION AND REC. SEL. SW(TC9164N) DATA	
15	P54/CNTR0	O	CLK	FUNCTION AND REC. SEL. (TC9164N) CLK	
16	P53/SRDY2	I	F-PHONO	Motor FUNC PHONO POSITION INPUT	"H"
17	P52/SCLK2	I	F-TUNER	Motor FUNC TUNER POSITION INPUT	"H"
18	P51/SOUT2	I	F-CD	Motor FUNC CD POSITION INPUT	"H"
19	P50/SIN2	I	F-LINE	Motor FUNC LINE POSITION INPUT	"H"
20	P47/SRDY1	I	F-TAPE1	Motor FUNC TAPE1 POSITION INPUT	"H"
21	P46/SCLK1	I	F-TAPE2	Motor FUNC TAPE2 POSITION INPUT	"H"
22	P45/TxD	O	V-UP	VR UP	"H"(UP)
23	P44/RxD	O	V-DOWN	VR DOWN	"H"(DOWN)
24	P43/INT2	I	IN T2	Silent mode input (FUNCTION, POWER, MUTE, REC)	"H"(Release)
25	P42/INT1	I	INT1	Silent mode input (SR only)	"H"(Release)
26	CNV <sub>SS</sub>	I	-	(to V <sub>SS</sub> )	-
27	RESET	I	RST	Reset terminal	"L"(Reset)
28	P41/INT0	I	BACK UP	BACK UP detection (Back up mode)	"L"
29	P40/INT4	-	-		-
30	X <sub>IN</sub>	I	XIN	Oscillation (4.19MHz)	-
31	X <sub>OUT</sub>	O	XOUT	Oscillation (4.19MHz)	-
32	V <sub>SS</sub>	-	V <sub>SS</sub>	Digital GND	-
33	P27/DB7	I	SR	Remote controller signal input	-
34	P26/DB6	I	MUT.K	Muting key input	"H"(ON)
35	P25/DB5	I	POW.K	Power key input	"H"(ON)
36	P24/DB4	I	T2.K	FUNCTION TAPE2 key input	"H"(ON)
37	P23/DB3	I	TL.K	FUNCTION TAPE1 key input	"H"(ON)
38	P22/DB2	I	LI.K	FUNCTION LINE key input	"H"(ON)
39	P21/DB1	I	CD.K	FUNCTION CD key input	"H"(ON)
40	P20/DB0	I	TU.K	FUNCTION TUNER key input	"H"(ON)
41	P17/AD15	I	PH.K	FUNCTION PHONO key input	"H"(ON)
42	P16/AD14	-	-		-
43	P15/AD13	I	T2→1	RECEV T2→T1 Copy Position input	"H"(ON)
44	P14/AD12	I	T1→2	RECEV T1→T2 Copy Position input	"H"(ON)
45	P13/AD11	I	SOURCE	Sel.SOURCE Position input	"H"(ON)
46	P12/AD10	I	OFF	Sel. OFF Position input	"H"(ON)
47	P11/AD9	I	CD	sel. CD Position input	"H"(ON)
48	P10/AD8	I	TUNER	sel. TUNER Position input	"H"(ON)
49	P07/AD7	O	AC RY	AC Primary Relay	"H"(ON)
50	P06/AD6	O	ST. IND	STANDBY IND	"H"(ON)
51	P05/AD5	O	T2.IND	FUNCTION IND TAPE2	"H"(ON)
52	P04/AD4	O	TL.IND	FUNCTION IND TAPE1	"H"(ON)
53	P03/AD3	O	LI.IND	FUNCTION IND LINE	"H"(ON)
54	P02/AD2	O	CD.IND	FUNCTION IND CD	"H"(ON)
55	P01/AD1	O	TU.IND	FUNCTION IND TUNER	"H"(ON)
56	P00/AD0	O	PH.IND	FUNCTION IND PHONO	"H"(ON)
57	P37/RD	O	F-DOWN	Motor FUNCTION DOWN	"H"(ON)
58	P36/WR	O	F-UP	Motor FUNCTION UP	"H"(ON)
59	P35/SYNC	O	F-MOTOR	Motor FUNCTION Start Torque	"L"
60	P34/φ	O	P-REG	PHONO POWER ON/OFF	"H"
61	P33/RESET OUT	O	P-MUT	PHONO MUTE except (FUNCTION PHONO)	"H"
62	P32/ONW	O	R-MUT	REC change MUTE	"H"
63	P31/DA2	O	F-MUT	FUNCTION change MUTE	"H"
64	P30/DA1	O	MUT-RY	Muting relay	"H"

## 6. PANEL FACILITIES

### FRONT PANEL 1

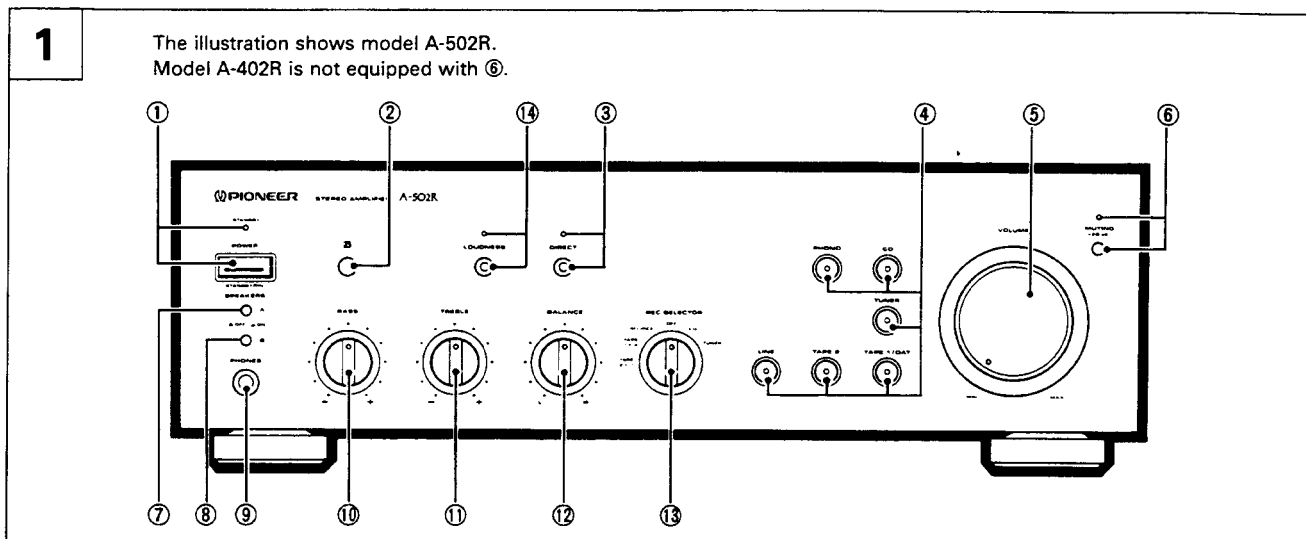

#### ① POWER STANDBY/ON switch/indicator

This is the switch for electric power.

**ON** : When set to the ON position, power is supplied and the unit becomes operational.

**STANDBY** : When set to the STANDBY position, the main power flow is cut and the unit is no longer fully operational. A minute flow of power feeds the unit to maintain operation readiness. When the STANDBY indicator lights, the unit is in STANDBY.

#### ② Remote control sensor window

#### ③ DIRECT button/indicator

Use this button/indicator when you do not wish to pass the output from input terminal equipment through the various frequency adjusting circuits (BASS, TREBLE, BALANCE, LOUDNESS) and adaptor terminals (ADAPTOR).

**On:** The indicator lights: The signals input through the input terminals are reproduced without passing through the various frequency adjusting circuits. This results in flat, pure sound which is a more faithful reproduction of the input source.

**Off:** The indicator goes out: The signal passes through the various frequency adjusting circuits.

#### ④ Input selector buttons/indicators

Use to select the playback source.

**LINE** : For playback with a component connected to LINE terminal.

**TUNER** : For AM or FM broadcast reception with a tuner.

**PHONO** : For record playback with a turntable.

**CD** : For compact disc playback with a CD player.

**TAPE 1/DAT** : For playback with a cassette deck or digital audio cassette deck connected to TAPE 1/DAT terminals.

**TAPE 2** : For playback with a cassette deck connected to TAPE 2 terminals.

#### NOTE:

*Circuit switching is performed by motor-driven rotary switches. Therefore, there is a slight time lag between pressing of the button and switching (A-502R only).*

#### ⑤ VOLUME control

Use to adjust the volume level.

#### NOTE:

*This unit is equipped with a circuit that attenuates LOUDNESS and TONE effects as volume is turned up.*

**⑥ MUTING button/indicator (A-502R only)**

Use to temporarily lower sound volume.

**On:** The indicator lights.

The sound volume is lowered to one-hundredth (-20 dB).

**Off:** The indicator goes off.

The sound will return to its previous volume.

**⑦ SPEAKERS A selector button**

Use this button to listen to the speaker systems connected to SPEAKERS A terminals.

**ON (■)** : Depressed position: Sound is heard from the speaker systems.

**OFF (■)** : Released position: No sound is heard from the speaker systems. Set to this position when listening with headphones.

**⑧ SPEAKERS B selector button**

Use this button to listen to the speaker systems connected to SPEAKERS B terminals.

**ON (■)** : Depressed position: Sound is heard from the speaker systems.

**OFF (■)** : Released position: No sound is heard from the speaker systems. Set to this position when listening with headphones.

**⑨ PHONES jack**

When using headphones, insert the plug into this jack.

**⑩ BASS tone control**

Use to adjust the low-frequency tone. The center position is the flat (normal) position. When turned to the right, low-frequency tones are emphasized; when turned to the left, low-frequency tones are de-emphasized.

**NOTE:**

- This control does not operate when DIRECT button is in the on position.
- When the indicator on the volume knob is positioned before the 11 o'clock position, the set tone control effect is obtained. When the indicator on the volume knob is positioned past the 11 o'clock position, the effect becomes increasingly weaker.

**⑪ TREBLE tone control**

Use to adjust the high-frequency tone. The center position is the flat (normal) position. When turned to the right, high-frequency tones are emphasized; when turned to the left, high-frequency tones are de-emphasized.

**NOTE:**

- This control does not operate when DIRECT button is in the on position.
- When the indicator on the volume knob is positioned before the 11 o'clock position, the set tone control effect is obtained. When the indicator on the volume knob is positioned past the 11 o'clock position, the effect becomes increasingly weaker.

**⑫ BALANCE control**

Should normally be left in the center position. Adjust balance if the sound is louder from one of the speakers. If the right side is louder, turn toward the L position and if the left side is louder, turn toward the R position.

**NOTE:**

This function does not operate when DIRECT button is in the on position.

**⑬ REC SELECTOR switch**

When this switch is set to a position other than SOURCE or OFF, the equipment selected by REC SELECTOR switch can be recorded from, irrespective of the settings of the input selector buttons and DIRECT button.

**TUNER** : To record from the equipment connected to TUNER terminals.

**CD** : To record from the equipment connected to CD terminals.

**OFF** : In this position, nothing from the REC terminals of TAPE 1/DAT and TAPE 2 is output. Set to this position when not recording; the cassette deck will be disconnected, improving sound quality.

**SOURCE** : To record from the equipment selected by input selector buttons.

**TAPE 1 ► 2** : To record (copy) from the cassette deck of TAPE 1/DAT terminals, to the cassette deck of TAPE 2 terminals.

**TAPE 2 ► 1** : To record (copy) from the cassette deck of TAPE 2 terminals, to the cassette deck of TAPE 1/DAT terminals.

**⑭ LOUDNESS button/indicator**

Use when listening at low volume levels.

**On:** The indicator lights: Boosts low and high frequencies to give added punch to playback even at low volume level.

**Off:** The indicator goes off: Should normally be left in this position.

**NOTE:**

This button does not operate when the DIRECT button is in the on position.

**REAR PANEL 2**

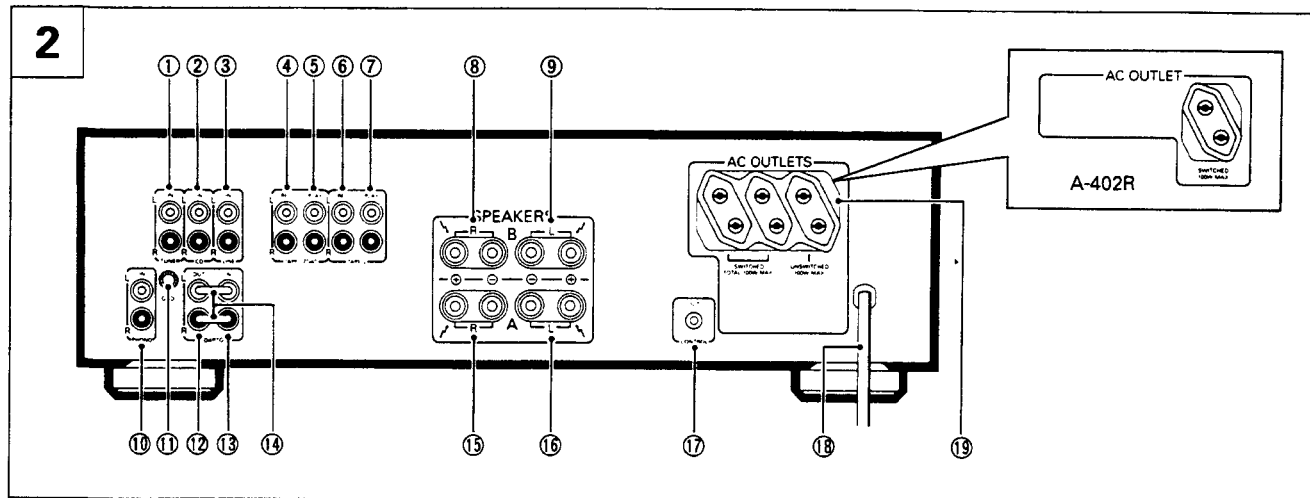

- ① **TUNER terminals**
- ② **CD terminals**
- ③ **LINE terminals**
- ④ **TAPE 1/DAT REC terminals**
- ⑤ **TAPE 1/DAT PLAY terminals**
- ⑥ **TAPE 2 REC terminals**
- ⑦ **TAPE 2 PLAY terminals**
- ⑧ **SPEAKERS B terminals (right channel)**
- ⑨ **SPEAKERS B terminals (left channel)**
- ⑩ **PHONO terminals**
- ⑪ **Turntable ground terminal (GND)**
- ⑫ **ADAPTOR OUT terminals**
- ⑬ **ADAPTOR IN terminals**
- ⑭ **Shorting bars**
- ⑮ **SPEAKERS A terminals (right channel)**
- ⑯ **SPEAKERS A terminals (left channel)**
- ⑰ **CONTROL OUT jack**  
This jack is for output of control signals when operating other components bearing the  mark with the attached remote control unit.
- ⑱ **Power cord**  
Connect this cord to an AC wall socket, or the AC outlet of an audio timer.
- ⑲ **AC OUTLETS**

## 7. SPECIFICATIONS

### [A-502R]

#### Amplifier Section

DIN Continuous power output (both channels driven at 1 kHz)	
T.H.D. 1 %, 4 Ω	100 W + 100 W*
T.H.D. 1 %, 8 Ω	70 W + 70 W*
Continuous power output (both channels driven at 20 Hz to 20 kHz)**	
T.H.D. 0.05 %, 4 Ω	75 W + 75 W*
T.H.D. 0.03 %, 8 Ω	55 W + 55 W*
Dynamic power output (on EIA dynamic test signal)	
4 Ω/2 Ω	110 W/135 W
Total harmonic distortion**	
20 Hz to 20 kHz, 30 W, 8 Ω	0.01 %*

• The above values are applicable when AC 230 V power is supplied.

Input sensitivity/impedance	
PHONO (MM)	2.8 mV/50 kΩ
CD, TUNER, LINE, TAPE	200 mV/50 kΩ
PHONO overload level	
1 kHz, T.H.D. 0.1 %	150 mV
Output level/impedance	
TAPE REC	200 mV/1 kΩ
Frequency response	
PHONO (MM)	20 Hz to 20 kHz ±0.5 dB
CD, TUNER, LINE, TAPE	5 Hz to 100 kHz, ±3 dB*
Tone control (volume control set at -30 dB position)	
BASS	±8 dB (100 Hz)
TREBLE	±8 dB (10 kHz)
Loudness contour (volume control set at -30 dB position)	
	+6 dB (100 Hz)/+3 dB (10 kHz)
Signal-to-Noise ratio (IHF short circuit, A network)	
PHONO (MM, 5 mV input)	89 dB*
CD, TUNER, LINE, TAPE	107 dB*
Signal-to-Noise ratio (DIN, continuous power/50 mW)	
PHONO (MM)	72 dB/70 dB*
CD, TUNER, LINE, TAPE	95 dB/80 dB*
MUTING	-20 dB

#### Power Supply/Miscellaneous

Power requirements	a.c. 220 — 230 Volts, 50/60 Hz
Power consumption	500 W
Dimensions	420 (W) x 360 (D) x 125 (H) mm
Weight (without package)	8.4 kg

#### Accessories

Remote control unit	1
Batteries (IEC R03, AAA)	2
Operating instructions	1

#### NOTE:

Specifications and design are subject to possible modifications without notice, due to improvements.

\*Measured with DIRECT button set to on.

\*\*Measured by Audio Spectrum Analyzer.

### [A-402R]

#### Amplifier Section

DIN Continuous power output (both channels driven at 1 kHz)	
T.H.D. 1 %, 4 Ω	70 W + 70 W*
T.H.D. 1 %, 8 Ω	55 W + 55 W*
Continuous power output (both channels driven at 20 Hz to 20 kHz)**	
T.H.D. 0.05 %, 4 Ω	50 W + 50 W*
T.H.D. 0.03 %, 8 Ω	40 W + 40 W*
Dynamic power output (on EIA dynamic test signal)	
4 Ω/2 Ω	85 W/95 W
Total harmonic distortion**	
20 Hz to 20 kHz, 20 W, 8 Ω	0.01 %*

• The above values are applicable when AC 230 V power is supplied.

Input sensitivity/impedance	
PHONO (MM)	2.8 mV/50 kΩ
CD, TUNER, LINE, TAPE	200 mV/50 kΩ
PHONO overload level	
1 kHz, T.H.D. 0.1 %	150 mV
Output level/impedance	
TAPE REC	200 mV/1 kΩ
Frequency response	
PHONO (MM)	20 Hz to 20 kHz ±0.5 dB
CD, TUNER, LINE, TAPE	5 Hz to 100 kHz, ±3 dB*
Tone control (volume control set at -30 dB position)	
BASS	±8 dB (100 Hz)
TREBLE	±8 dB (10 kHz)
Loudness contour (volume control set at -30 dB position)	
	+6 dB (100 Hz)/+3 dB (10 kHz)
Signal-to-Noise ratio (IHF short circuit, A network)	
PHONO (MM, 5 mV input)	84 dB*
CD, TUNER, LINE, TAPE	106 dB*
Signal-to-Noise ratio (DIN, continuous power/50 mW)	
PHONO (MM)	71 dB/67 dB*
CD, TUNER, LINE, TAPE	95 dB/71 dB*

#### Power Supply/Miscellaneous

Power requirements	a.c. 220 — 230 Volts, 50/60 Hz
Power consumption	440 W
Dimensions	420 (W) x 360 (D) x 125 (H) mm
Weight (without package)	6.7 kg

#### Accessories

Remote control unit	1
Batteries (IEC R03, AAA)	2
Operating instructions	1

#### NOTE:

Specifications and design are subject to possible modifications without notice, due to improvements.

\*Measured with DIRECT button set to on.

\*\*Measured by Audio Spectrum Analyzer.