

# POWER AMP ASS'Y (717-0074-00-R)

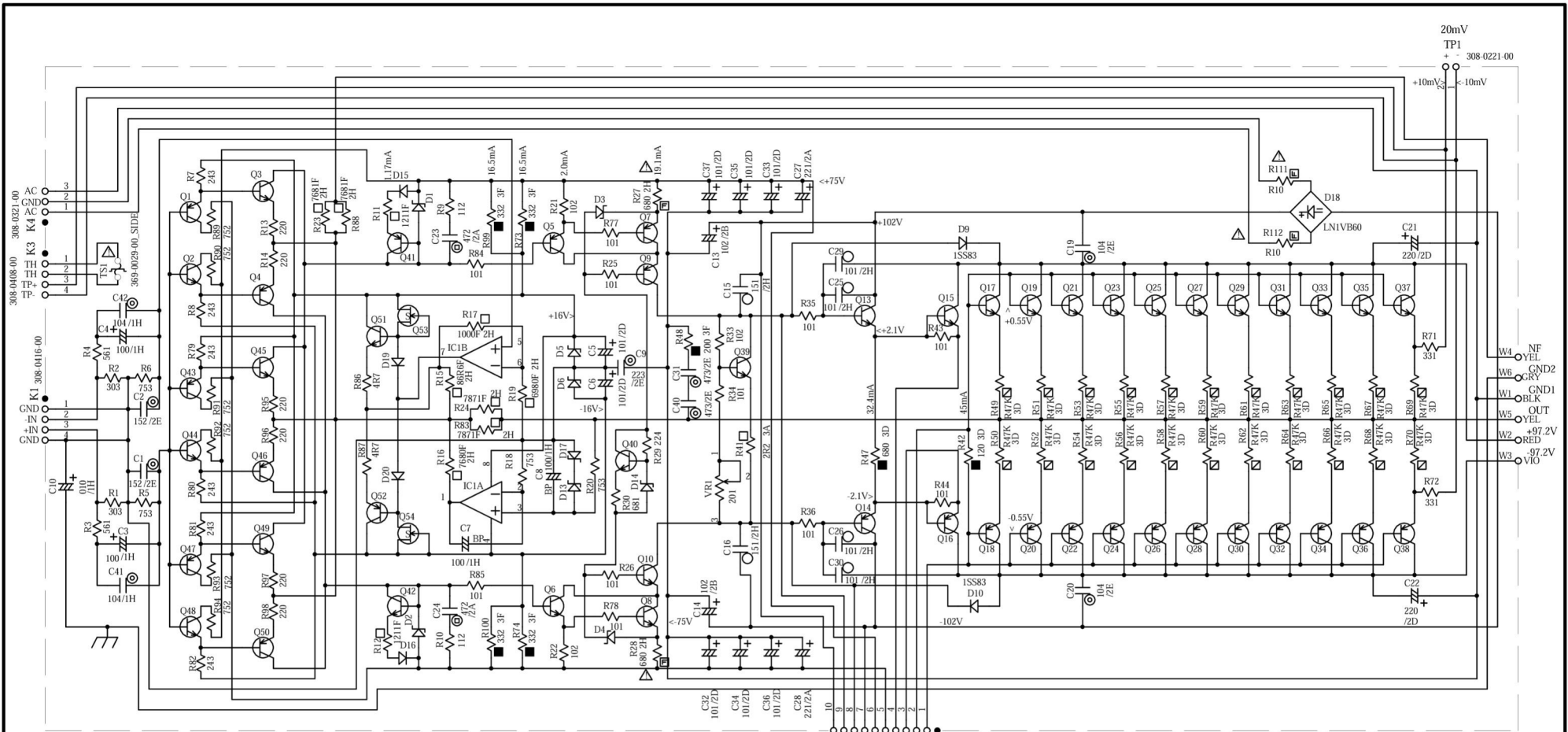

### SEMICONDUCTORS

IC1	NJM4580D-D	Q9	2SA1480-E/F	Q16	2SA1986-O	Q51	2SC2547-D/E	D1,2	HZ153L	D13,17	HZ6C2L
Q1,4,43,46,47,50	2SA1376A-K	Q10,40	2SC3790-E/F	Q17,19,21,23,25		Q52	2SA1085-D/E	D3,4	HZ6A1L	D14	HZ2ALL
Q2,3,44,45,48,49	2SC3478A-K	Q13	2SC4793	27,29,31,33,35,32	2SC5358-O/R	Q53,54	2SK330-Y	D5,6	1Z15A	D15,16	MA167
Q5,7,41	2SA1145-Y	Q14	2SA1837	Q18,20,22,24,26	2SA1986-O/R			D9,10	1SS83	D18	LN1VB60
Q6,8,42	2SC2705-Y	Q15	2SC5358-O	Q39	2SC4685					D19,20	MA165

### CAUTION

⚠ Attention mark indicating critical components for safety.  
Replacement must be made with identical parts of specified part number.