

diyAudio Tube Constant Current Source Board Project

The diyAudio.com CCS PCB is an array of circuit boards for constructing various constant current sources/sinks for prototypes or as modules in a final design. The topology of all the circuits is the same- a cascode bipolar with an LED reference. I've found these to work really well and they are simple and inexpensive to build. There are three versions of this circuit – Low Voltage NPN, High Voltage NPN, & High Voltage PNP – with 2 instances of each on the circuit board array.

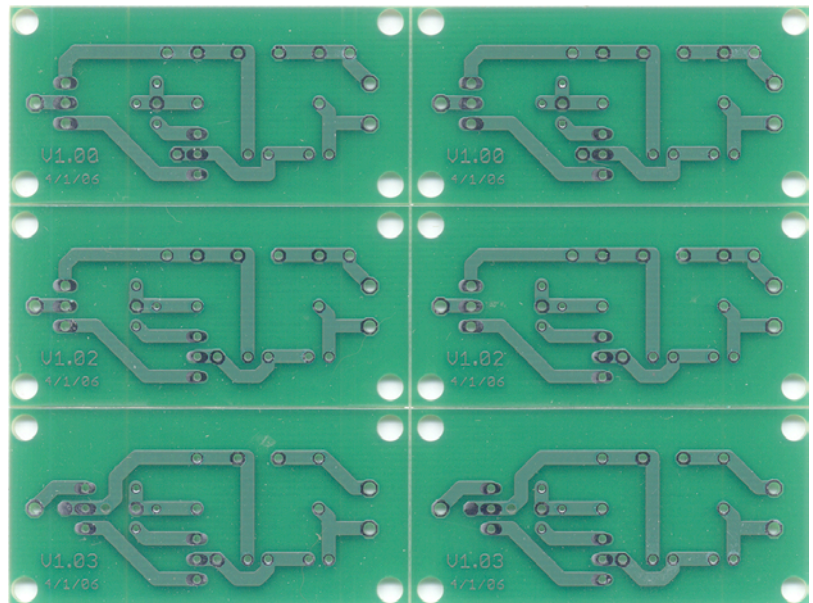
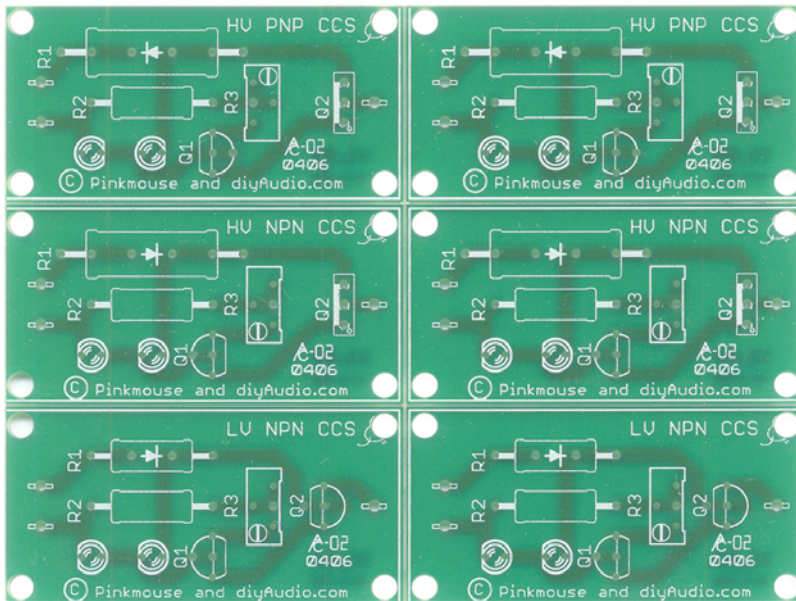

This project came about when planet10 contacted Morgan Jones (of Valve Amplifier fame) about using a 317 for a CCS. He said that wasn't good enough. With his permission pinkmouse came up with circuit boards for the constant current sources in Valve Amplifiers. Input & assistance from SY, EC81010, & Gregg-the-Geek.

board layout © 2006 diyAudio.com + Al Crooks
documentation © 2006 diyAudio.com + Stuart Yaniger + David Dlugos
circuit design from Valve Amplifiers, Morgan Jones, Newnes, VA3 ISBN is 0-7506-6594-8

LV NPN CCS: This is a useful current sink for cathode followers or long-tailed pairs where the voltage/power requirements are not too steep. It can also be used in solid state amps as an emitter load for a differential pair or for level shifting. You can use very fast, high hfe transistors and get excellent performance.

HV NPN CCS: This version will allow for a bigger transistor to handle most of the voltage. It will typically be useful for cathode followers or long-tailed pairs where there is a significant voltage drop and consequent power dissipation requirement.

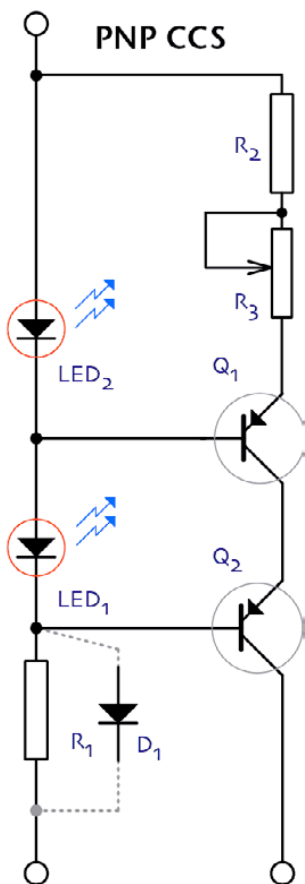
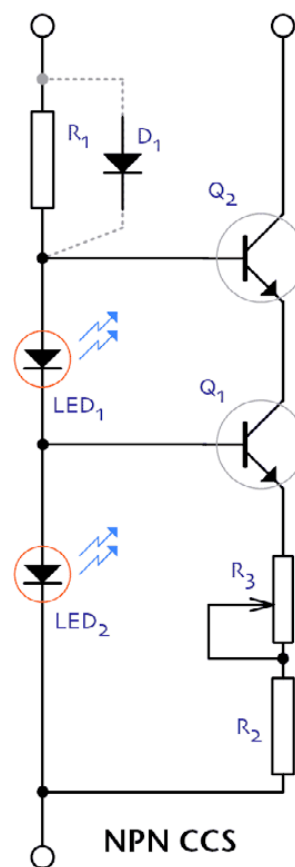

HV PNP CCS: This version is useful for plate loads in tube circuits. (figure 2)

Each version has three external connections: supply voltage, output, and return, and is adjustable via a trim-pot.

Theory of Operation:

The LED sets a 1.7V reference between the base of Q₁ and the return. Since the V_{be} drop of Q₁ is about 0.7V, there must be about 1.0V across the series combination of R₂ and R₃. Thus, the current is constant. Q₂ buffers Q₁'s collector from the voltage swings at the output. R₁ sets the current through the reference LED; the second LED is used to bias the upper transistor Q₂. Output impedance is approximately:

$$R_{out} = (h_{oe}(Q_2))^{-1} + (R_2 R_3) h_{fe}(Q_1) h_{fe}(Q_2)$$

The first term is usually negligible compared with the second term.

There is a much more complete treatment of this in "Valve Amplifiers" by Morgan Jones, along with worked examples and application data. I would recommend reading through his treatment very carefully.

Parts calculation and examples:

LV NPN CCS: This is the easiest and capable of the best performance of the bunch. Good choices for the NPN transistors are high h_{fe} , high f_t units, but there's nothing exotic or critical needed. Availability should guide you.

The reference LED should be a cheap red unit. Surplus is a good thing here. Although high efficiency or high intensity LEDs will work here, they're not optimum. The series LED is very noncritical; it can be whatever color strikes your fancy. Its effect is to set the base-collector voltage of Q_1 , so the adventurous might want to experiment a bit here. It can even be a resistor (1k would be a typical value).

The current through the reference string is set by R_1 . 5mA is a good minimum for low noise performance; more wouldn't hurt. All this current does is light up the LEDs so that they can set the proper internal voltages- its exact value is not critical.

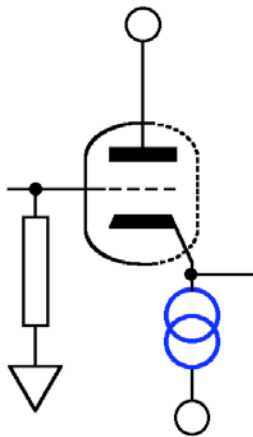

Let's look at an example use. We need to bias up a cathode follower using an ECC88. We want to run 10mA current through the tube. We have $\pm 12V$ supplies.

With those requirements in hand, we pull out a red LED for a reference, a green LED for the series unit, and proceed to calculate R_1 on the assumption that we'll use the +12V as our supply and the -12V as the return. So there's 24V across the CCS circuit. The sum of the drops across the LEDs is about 3.7V. So the voltage across R_1 is $24 - 3.7 = 20.3V$. Call it 20V (this is NOT a critical value!). For a 5mA current, $R_1 = 20V/5mA = 4k$. Anything near that (3k9 is a standard value) will work fine. The power across the resistor is $(20V)(5mA) = 100mW$. So a resistor rated at 1/4W or better will work.

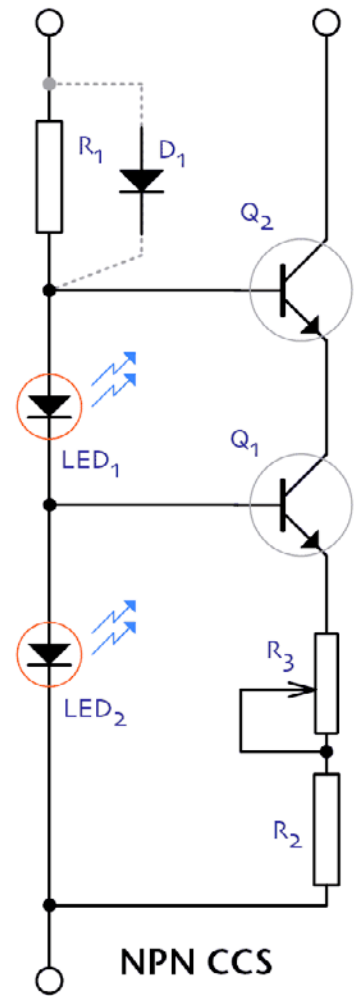

The transistors can be any general purpose NPN with a high f_t and h_{fe} with a 30V or greater breakdown; Jones recommends BC549 or a 2N3904, I've been using PN2222. Now, the emitter resistance (series combination of $R_2 + R_3$) may be calculated. The reference LED has a 1.7V drop. The forward V_{be} of Q_1 is 0.7V. So the voltage across $R_2 + R_3$ is then approximately 1.0V. For the desired 10mA set current, $R_2 + R_3 = 1.0V/10mA = 100\Omega$, or 100R. With this value of emitter resistance and assuming that Q_1 and Q_2 have h_{fe} s of 300, the output impedance of this CCS is about 10M. Not bad!

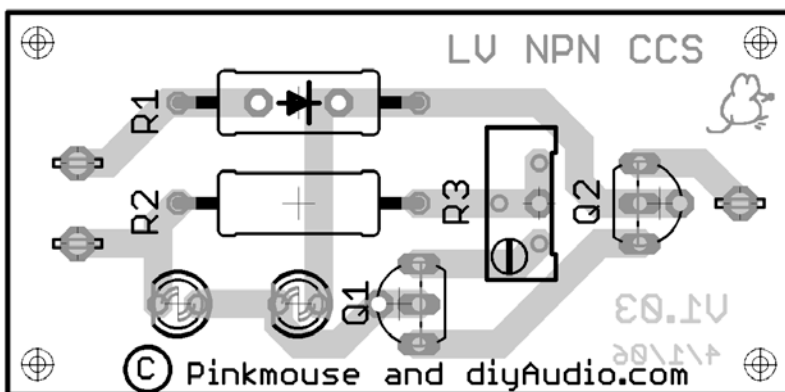

To choose values for R_2 and R_3 , it's best to have adjustability up and down by 20% or so. So R_2 could be 82R, R_3 a 50R trimpot. For a non-critical application (like the assumed cathode follower, which will be just as happy at 10mA or 9.7mA as at 10.0mA exactly), you could just use a 100 ohm fixed resistor and short out the R_3 trace.

HV NPN CCS: Just about everything said previously is the same here. The only difference is that R_1 will probably have to be larger and Q_2 will need to hold off more voltage and dissipate more power. To this end, the board is designed to accept a TO220/202 type package with a small heatsink. Q_1 , as before, can be a small-signal low voltage NPN.

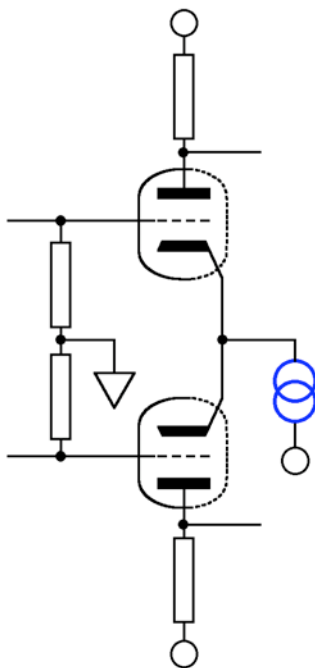

Let's look at a typical example. We have a Mullard-type amplifier with an input voltage amplifier direct-coupled to a long-tailed pair. We wish to convert the long-tailed pair to constant current operation, allowing us to have balanced plate resistors and a much more symmetric drive. We will assume that the LTP is a 6SN7 with 8mA per section current (16mA total). There is a 400V supply, and the grid voltage due to the direct coupling from the voltage amp is about 100V. That means that the cathode voltage will be slightly higher than that, perhaps 104V.

R_1 will now connect to the 400V rail, the return to ground. So the voltage across R_1 will be $400 - 3.7V$, which can be approximated as still 400V. To get 5mA for the reference string current, we calculate $R_1 = 400V/5mA = 80k$. That's close to 82k, a standard value, so we'll use that number. The power dissipated is $P = (400V)(5mA) = 2W$. For reliability, you'll want to use at least a 3 or 4W wirewound, and stand it away from the board a bit to let it have some air for cooling.

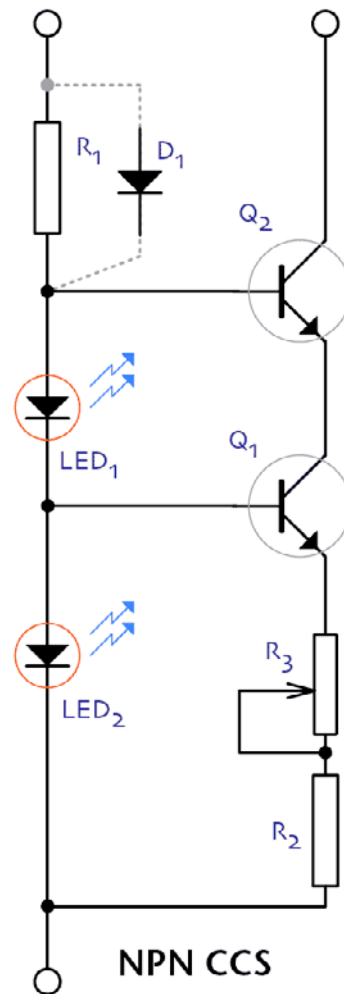

Now to the emitter resistances. Desired set current was specified at 16mA, the voltages are just as in the last example, so $R_2 + R_3 = 1.0V/16mA = 62R5$. As before, if we want this to be adjustable, we can use a 47R fixed resistor in series with a 25R trimpot. Output impedance is less impressive than before; the lower h_{fe} of Q_2 is mostly responsible for this. Nonetheless, with typical h_{fe} values for an MJE340 and PN2222, we have an output impedance of about 650k, at least an order of magnitude better than the long-tail resistor the CCS replaces. If this is not enough, you can kludge things by increasing the reference voltage and the emitter resistance. For example, if you tie two red LEDs in series for a 3.4V reference, the emitter resistor drop will be 2.7V, so the emitter resistance would increase to $R = 2.7V/16mA = 169R$. This would give an output impedance of about 1M6, a pretty hefty number. See the "Enhancements" section.

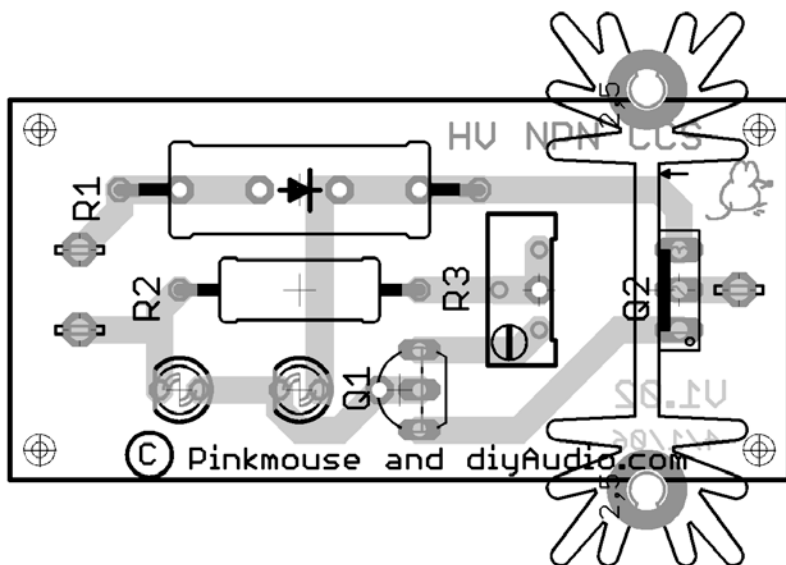

The upper transistor, Q_2 , will need to be a medium power, high voltage type like a TIP50 or MJE340. For the estimated 100V drop across the CCS, power will be $P = 100V * 16mA = 1.6W$. You might get by without a heat-sink, but a small one would reduce any chances of thermal damage. The lower transistor, Q_1 , can be as before, a BC549, 2N3904, PN2222, or the equivalent, since the voltage across it will never exceed 2 or 3V.

HV PNP CCS: This circuit is really just the same as the last ones, but turned upside down. The performance will be slightly worse than the NPN versions because of the lower h_{fe} of high voltage PNP transistors. Because this board will usually be used in applications requiring some power dissipation and voltage (plate loads), again provision is made for power devices in TO202/220 packages, along with space for a small heat-sink.

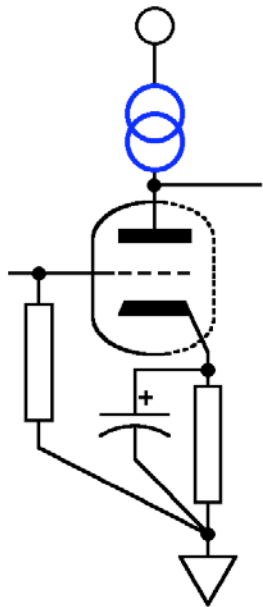

As our example, we will consider a 12AT7 grounded cathode voltage amplifier running at 2mA plate current with a 350V rail. The CCS will minimize distortion and maximize gain when used as a plate load. Now in this case, the return is connected to the high voltage supply and the supply lead is grounded. As before, the voltage across R_1 is approximately the HV rail voltage (350V). For 5mA reference string current, R_1 would then be $R_1 = 350V/5mA = 70k$. A close standard value is 75k. Power dissipated is about $P = (350V)(5mA) = 1.75W$. Again, a 3W minimum rating should be used.

The emitter resistors can be calculated as before. With a 1.7V reference and a 0.7V V_{be} drop, the resistors have approximately 1.0V across them. For our desired 2mA set current, $R = 1.0V/2mA = 500\Omega$ or 500R. This can be made from a series combination of 450R and a 100R trimpot.

Transistor selection is a bit more limited than before. Q_2 is likely to have something like 200V across it, so we need to consider dissipation. Power would be roughly $P = 200V * 2mA = 400mW$. That's barely within the capability of most TO92-packaged transistors (remember de-rating!), so we should look to something a little bigger. The only high voltage PNP with moderately large dissipation that's generally available is the MJE350; it's overkill for this application, but at least we won't need a heat-sink. What the world needs is a 1 or 2W PNP with a 400-500V breakdown voltage and a high h_{fe} . If anyone knows of such a beast, please tell us about it! For Q_1 , we can look to small, low voltage units like 2N3906, BC558, or the like.

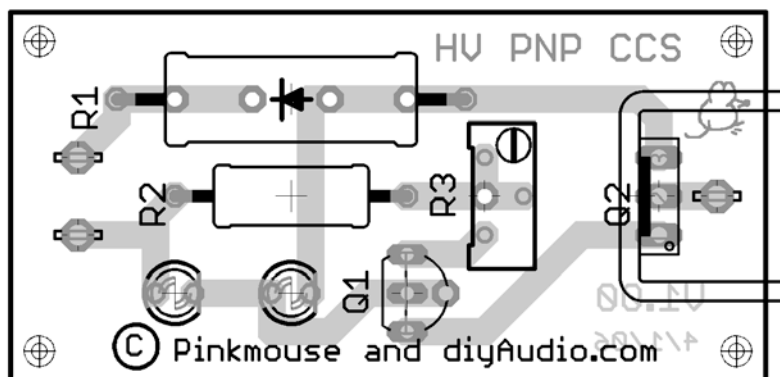
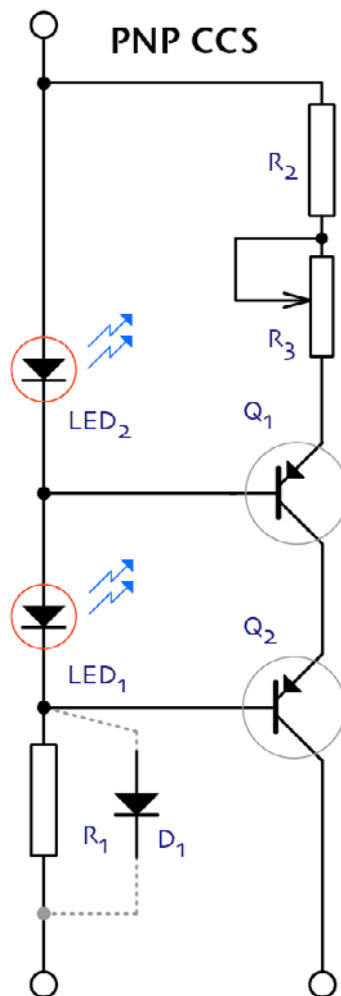

For this example, and assuming 2N3906 ($h_{fe}(typ) = 200$) and MJE350 ($h_{fe}(typ) = 40$, $1/h_{oe} = 50k$), the output impedance is about 4M.

Enhancements

The use of a CCS in many circuits is a lovely way of gilding the lily. A true diyAudio obsessive will wonder what can be done to plate it with rhodium.

One way is to use a CCS in place of R_1 . This minimizes any current changes through the reference LED, making the reference voltage a bit more stable. Additionally, it prevents any power supply noise from coupling into the reference node at Q_1 's base. For the LV NPN, you can use a two-terminal current source diode like the Siliconix CR470. For higher voltages, a discrete CCS would be needed (the two terminal CCS diodes have a low maximum voltage), but gives the improvement is smaller than the LV case because the resistor it replaces is larger.

A significant enhancement results from increasing the reference voltage. This will cause the emitter resistor to be larger, and thus the CCS impedance will rise proportionately. One example was mentioned in the HV NPN examples, connecting two LEDs in series. Another nifty way to increase the reference voltage is to substitute a low noise reference like LM329 for the reference LED. The LM329 gives a 6.9V reference, so that value must be substituted into the equations for calculating the resistor values, replacing the 1.7V red LED voltage. For example, in the HV NPN circuit (which had a source resistance of 650k), changing the reference to an LM329 requires that $R_2 + R_3 = (6.9V - 0.7V) / 16mA = 390R$. Plugging that into the output impedance formula, we find that it has increased from 650k to 4M7, a factor of eight improvement.

Master Equations

$$R_1 = (V_{\text{supply-return}} - V_{\text{LED}_1} - V_{\text{LED}_2}) / 5mA \quad (\text{At high supply voltages, the LED terms can be ignored})$$

$$R_2 + R_3 = (V_{\text{ref}} - 0.7) / i_{\text{set}}$$

Appendix A: Suitable Devices for Q₁ & Q₂

A list of some parts to look for:

LV NPN		HV NPN		HV PNP	
Q ₁	Q ₂	Q ₁	Q ₂	Q ₁	Q ₂
BC549		BC549	MJE340	2N3906,	MJE350
2N3904		2N3904	PN2222	BC558	MPSA92
PN2222		PN2222	TIP50	BC557C	
			MPSA42		

The important thing is that the transistor associated with the reference voltage LED doesn't have much voltage across it no matter which circuit it's in, so it can always be optimised for high h_{fe} . In Europe, that means BC549C (NPN, $h_{fe} > 400$) and BC557C (PNP, $h_{fe} > 400$) are my favourites. There's no point in buying such transistors in quantities of less than 100 – they're so cheap when you buy 100. The transistor nearest the load needs to be more robust and there are very few choices, for NPN it's between MPSA42 (625mW) and MJE340 (20W), for PNP it's between MPSA92 (625mW) and MJE350 (20W). Don't use the bigger transistor when the little one will do, not only will h_{fe} be lower, but C_{out} will be higher, so HF performance will be poorer.