



For more Hi-Fi manuals and set-up information  
please visit [www.hifiengine.com](http://www.hifiengine.com)

# **ARCAM**

## **DELTA 290 AMPLIFIER SERVICE MANUAL**

# ARCAM DELTA D290 SERVICE MANUAL

Issue 1 Serial No. 001 -

(Paul Newton April 93)

Arcam Drawing No. H04/0018

## Contents

### Circuit Description

Input/Output Selection .....	2
Tone Control & Preamp Out/Power Amp In .....	2
Power Amplifier .....	2
Power Supplies .....	2
Protection/Mute circuit .....	3
Disc Stage (optional) .....	3
Change of Mains Voltage .....	4
Service Notes .....	5
List of Circuit Diagrams .....	7

## **Circuit Description**

### **Input/Output Selection** (circuit diagram sheet 1)

The D290 has 6 line level inputs as standard selected by use of the motorised listen switch, SW201.

The use of the 'record' switch SW202 allows recording of one source whilst listening to another.

### **Tone Control & Preamp Out/Power Amp In** (circuit diagram sheet 3)

The tone control stage on the D290 is based around a dual op-amp IC2. The first half provides a buffer stage for the tone controls and the second one with its frequency dependent feedback is used as the tone control itself.

The output of the tone control then passes through the balance control RV201 and then onto the power amp stages and the preamp out buffer stage formed by IC203.

The tone controls and balance pot can be bypassed by use of the 'direct' switch SW205.

The D290 can be driven from an external preamplifier source by moving the internal switch SW206 to disconnect the D290 preamp from the power amp.

### **Power Amplifier** (circuit diagram sheet 4 & 7)

The signal from either the D290 input sockets or an external preamp enters the power amp stage via C12 and R35.

Q10, 11 form a long, tailed pair driven by the current source formed by Q12 and 13.

Q6 is the Class A stage driving the Quasi complementary output stage of Q4 and Q5, and mosfet's Q1, 2.

IC1 is a d.c. servo used to maintain a low d.c. offset at the speaker outputs.

### **Power Supplies** (circuit diagram sheets 2 & 4)

The D290 is powered by a toroidal transformer with 2 sets of secondary windings.

The main windings are used to provide +/-44V D.C. after rectification and smoothing by diodes D201-204 inc. reservoir capacitors C201, 202.

The second winding is rectified to provide an unregulated supply voltage for the motor driver ics, IC402, 403 and is also smoothed and regulated with a zener diode (D402 and associated components) to provide a stable voltage for the micro controller IC401.

**Protection/Mute circuit** (circuit diagram sheet 5)

The protection and mute functions are carried out by IC501. This performs turn on delay, d.c. offset detection and thermal cutout and with use of a bicolour LED displays the status of the amplifier 'Green' for ready and 'Amber' for when the speakers are disconnected internally because of a fault condition or on initial power up whilst the 5 second switch on delay mute is operating.

The thermal cut out is set at 80° C by the thermistor TH501 mounted close to the output device heatsinks.

**Disc Stage (optional)** (circuit diagram sheet 6)

The optional phono stage board available for the D290 provides amplification and RIAA equalization for both moving coil (MC) and moving magnet (MM) cartridges.

Transistors Q2-5 and their associated components provide the extra gain required for moving coil cartridges when required Z1 forms a flat response gain stage with the gain set by R3 and R4. R5 and C2 provide a low pass filter used as the high frequency part of the RIAA de-emphasis. The negative feedback loop around IC2, R7,8,9,10 and C3 provides the active low frequency RIAA de-emphasis.

The pcb mounted switch selects between MM or MC. The board is powered by +/-15V regulated rails from the main pcb and the +15V rail is then regulated to 6.3V by Q1 and D1, D2 to power the moving coil stage.

**NOTE.**

When the phono option is fitted the 'AUX' inputs become 'outputs' from the phono stage and could be used to feed direct to a tape recorder.

## Change of Mains Voltage

**WARNING** - the unit **must** be unplugged from the mains when replacing the fuse or rewiring the transformer as the mains inlet and fuse are at mains potential even with the unit switched off.

### Units with PCB less than Issue 7 (Serial No. < 2401)

To rewire the D290 for use at different voltages rewire the primary of the transformer by referring to the pcb and the table below and fit the appropriate fuse. The only wires that move are the brown and orange ones. The black wire does not move.

#### 230V WIRING (1.6A ANTI-SURGE FUSE)

<b>BROWN</b>	<b>BLACK</b>
<b>SPARE WIRE</b>	<b>ORANGE</b>

#### 115V WIRING (3.15A ANTI-SURGE FUSE)

<b>ORANGE</b>	<b>BLACK</b>
<b>SPARE WIRE</b>	<b>BROWN</b>

### Units with PCB Issue 7 or greater (Serial No. > 2401)

These D290's can be set for use on 230v or 115v mains supplies.

There are 2 mains fuseholders in the unit - one marked 230v & the other 115v and the fuseholder with the fuse fitted to it determines the working voltage.

To change voltage remove the fitted fuse and fit the correct fuse to the other fuseholder.

The correct fuses are:     1.6A antisurge for 230v  
                                  3.15A antisurge for 115v

## Service Notes

Various running changes were incorporated on the D290 culminating in the issue 7 pcb. The changes are listed below with approximate serial numbers.

1. Serial No. 464 onwards  
10nF capacitor added across R506 to prevent speaker protection cutting in if SP1 button was switched in/out quickly several times.  
C601 on the remote receive pcb changed to 220pF polystyrene to improve reliability of the remote receiver when the remote control was used close to the unit.
2. Serial No. 761 onwards  
Mains fuse value updated from 1.25A to 1.6A antisurge.
3. Serial No. 1345 onwards  
R4, 104, 6, 106 replaced with fusible resistors.
4. Serial No. 1444 onwards  
Microprocessor software updated to Version 7. This prevents problems with random selection of the listen selector and also misalignment of this switch causing loss of channels which can be regained by putting switch in between its click stop positions.
5. Serial No. 1607 onwards  
R4, 104, 6, 106 fitted under pcb closer to the output devices.  
Transistor/resistor added across R1,101.  
C1, 101, 7, 107, 5, 105, Q13, 113 removed.  
R22, 122 changed to 3K3 MF & C6, 106 changed to 22pF polystyrene.
6. Serial No. 1925 onwards  
C5,105 replaced with 10pF polystyrene in series with 33K MF.

Changes 5 and 6 above were done to reduce the failure rate of the output devices due to occasional instability.

7. Serial No. 2401 onwards  
Issue 7 pcbs in production and incorporate the above changes plus adding a relay to the preamp output, to prevent switch on thumps if using these sockets, and some track layout revisions.
8. Serial No. 2674 onwards  
The SM042 output devices became obsolete so IRFP240 devices were used to replace them involving modification to the underside of the pcb, (see service note 1 18/11/93), as they are a different transistor package.  
Any units requiring replacement output devices will require this modification.

### D290 SERVICE NOTE 1 Issue 2 18/11/93

The MOSFET devices used on the D290 amplifier have become obsolete and it has been necessary to find a replacement device. The replacement device is a TO3-P plastic package and requires modification to the pcb underneath as shown below.

From serial number 2674 onwards all D290's will have the new type devices.

It is advisable to replace all 4 devices to this new type and at the same time the following items should be checked and replaced if the IQ will not adjust.

Change R16,116 to 56K from 100K.

Change R17,117 to 4K7 from 3K3.

These changes give a slightly wider range for the IQ (quiescent current) setting required with these devices. The IQ should be checked after replacing the output devices and set to 4mV across R1,101 with the unit cold.

Check that R55,155 are 100K and *not* 120K.

Remove C5,105 (33pF) and replace with 10pF polystyrene in series with 33K metal film resistor.

Remove C7,107 (220pF)

Change C6,106 to 22pF from 10pF polystyrene capacitor.

Change R22,122 to 3K3 from 4K7 metal film resistor.

These changes should prevent any tendency for instability which has caused sudden and unexplained failure of the output stage.

If you order D290 output devices from us you will be sent these new devices as a kit of parts, listed below, to enable all of the above to be carried out.

2 x 22pF polystyrene capacitor	2E022
2 x 10pF polystyrene capacitor	2E010
2 x 3K3 metal film resistor	1H233
2 x 100K metal film resistor	1H410
2 x 33K metal film resistor	1H333
2 x 56K metal film resistor	1H356
4 x IRFP 240 Plastic MOSFET	4K240
6 x rubber sleeving	K5340
4 x mica washer	F088

NOTE: The extra pieces of sleeving should be cut into 8 pieces and fitted into the holes that the MOSFET legs go through to prevent them shorting to the heatshunt. The mica washers have to be trimmed to fit and should be smeared with heatsink compound on both sides to ensure good thermal conductivity. Links must be fitted under the pcb as shown below otherwise the devices will not receive their supply voltage.

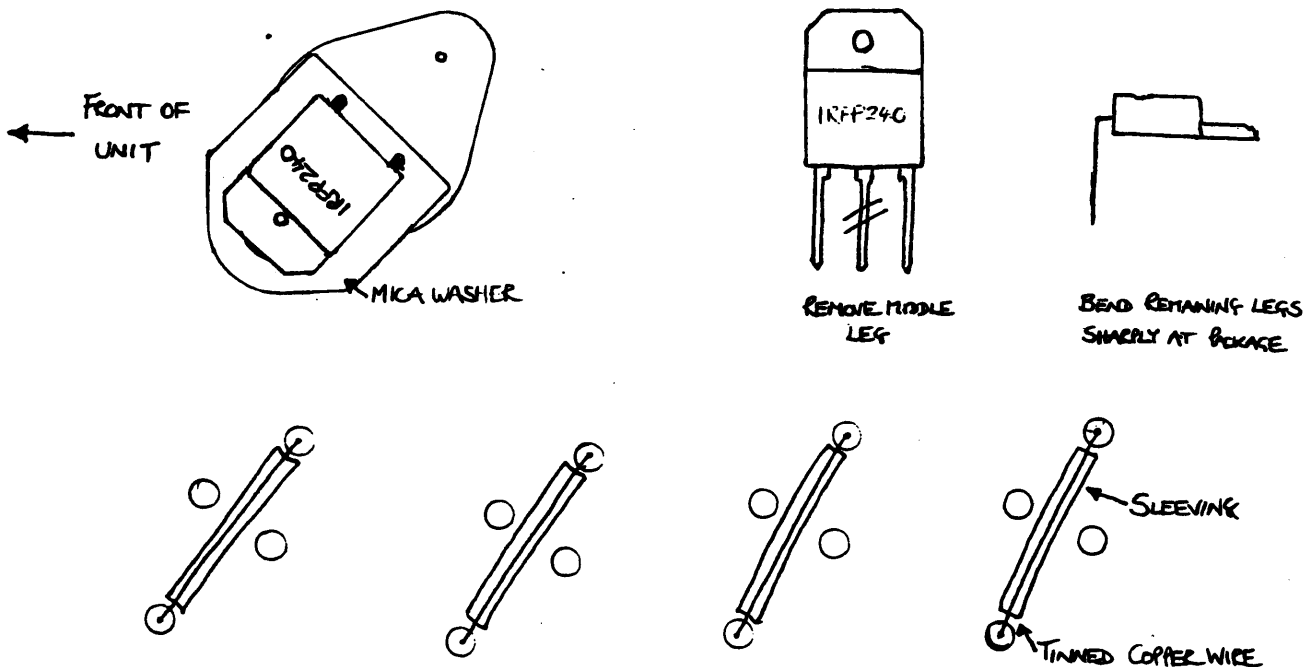

<b>Circuit Diagrams</b>
Input Selection
Remote Receive & Control Circuit
Tone Controls & Preamp Out
Power Amplifier Issue 7
Protection & Mains Input
MM/MC Phono Stage
Power Amplifier < Issue 7

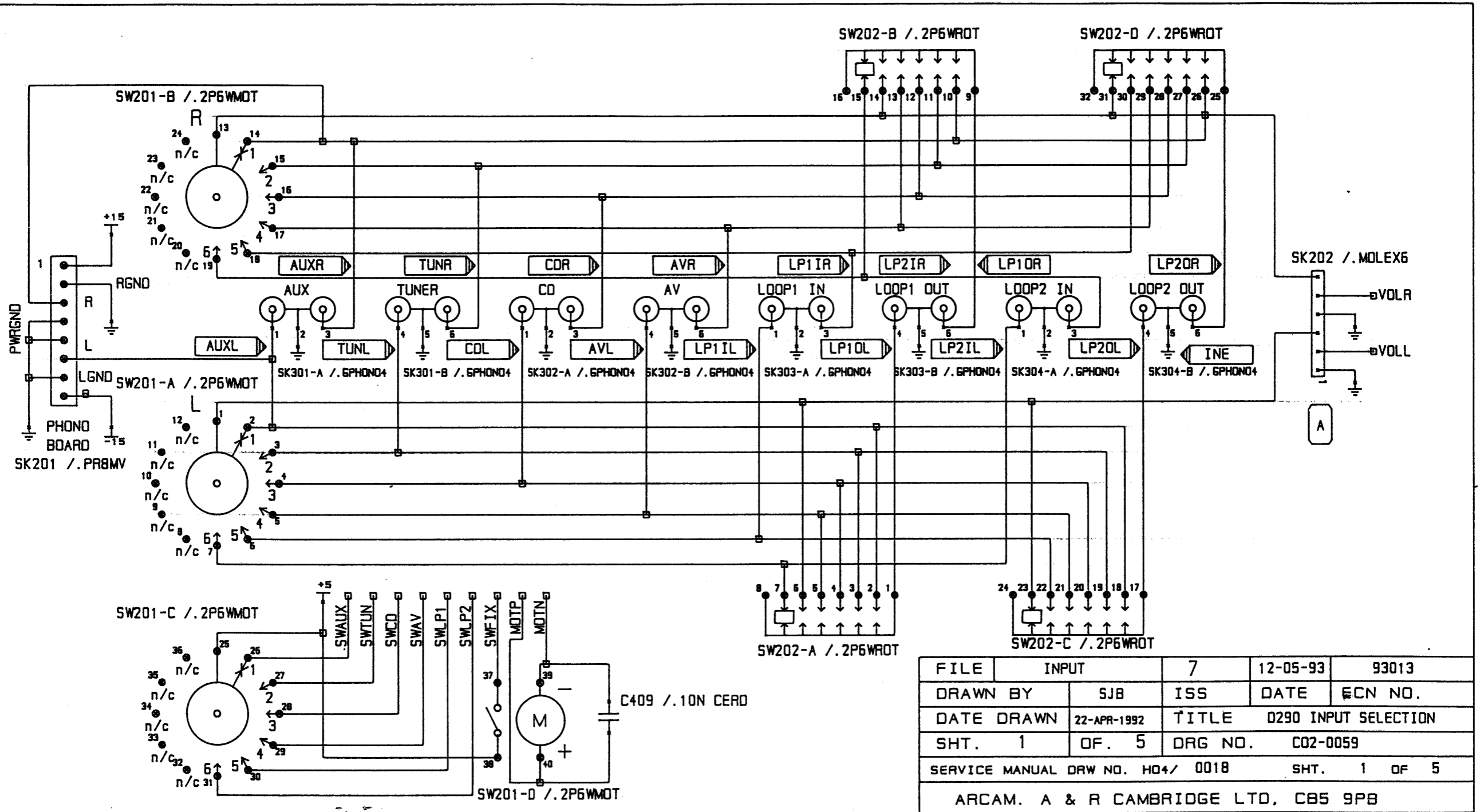

FILE	INPUT	7	12-05-93	93013
DRAWN BY	SJB	ISS	DATE	ECN NO.
DATE DRAWN	22-APR-1992	TITLE	D290 INPUT SELECTION	
SHT.	1	OF.	5	DRG NO. C02-0059
SERVICE MANUAL DRW NO. HO4/ 0018			SHT. 1 OF 5	
ARCAM. A & R CAMBRIDGE LTD, CB5 9PB				

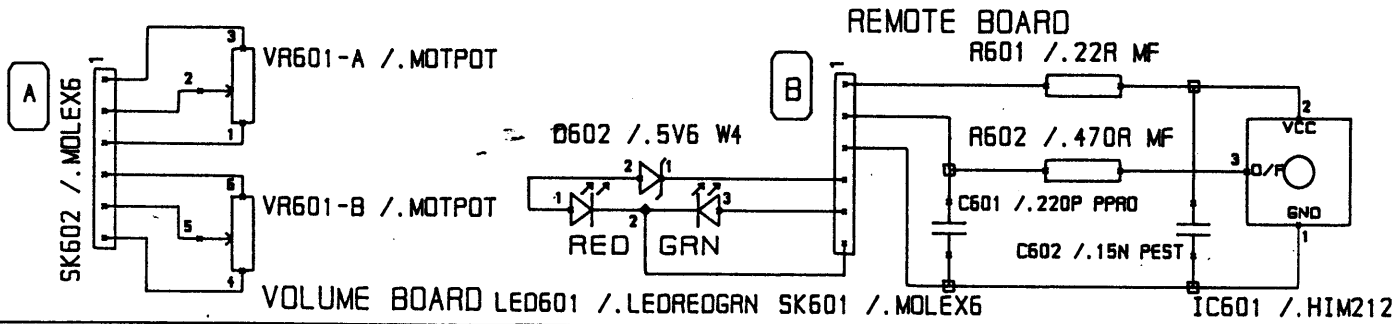
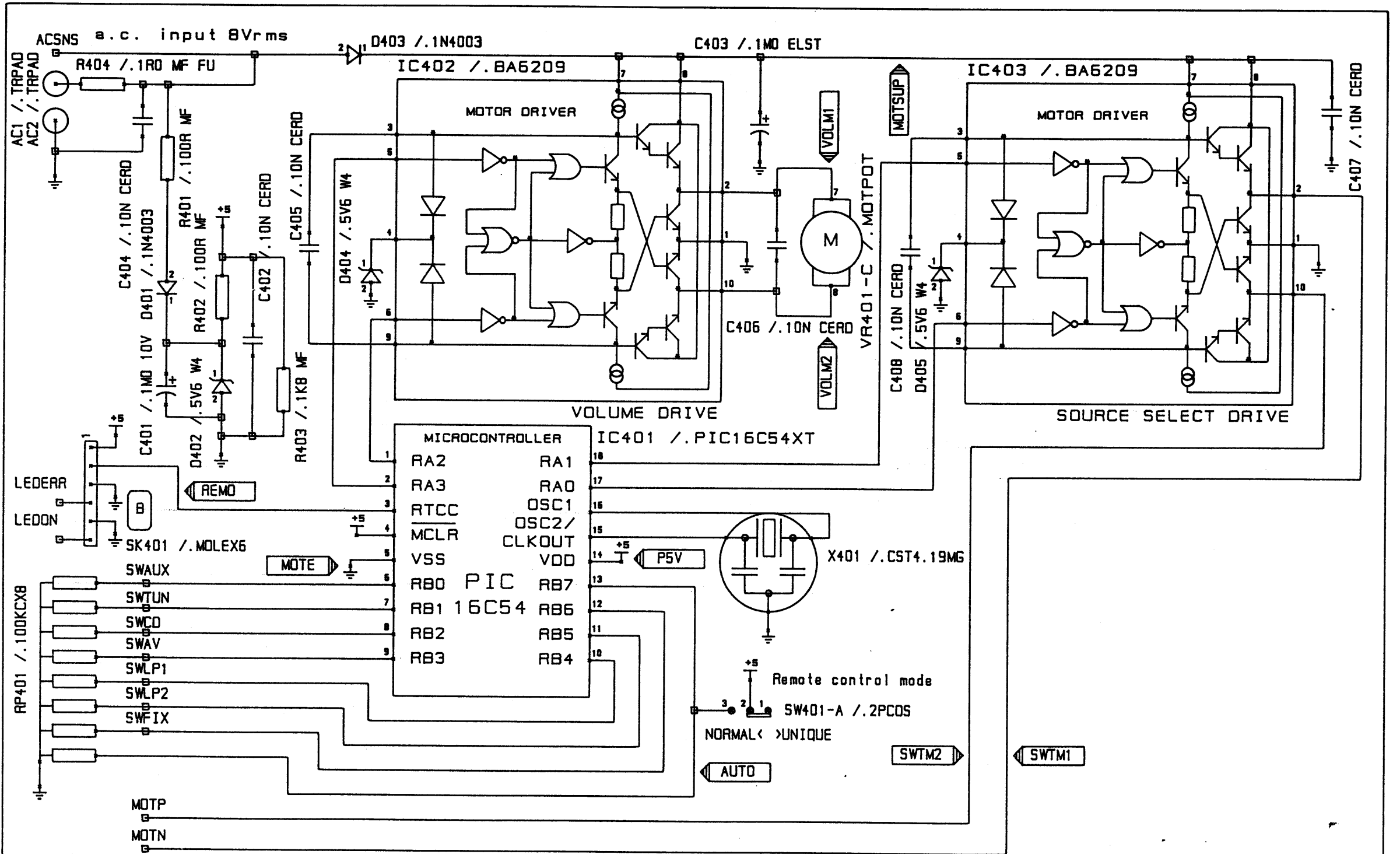

FILE	REMOTE	7	12-05-93	93013
DRAWN BY	SJB	ISS	DATE	ECN NO.
DATE DRAWN	23-APR-1992	TITLE	D290 REMOTE CONTROL	
SHT. 2	OF. 5	DRG NO.	C02-0059	
SERVICE MANUAL DRW NO. HQ4/ 0018			SHT. 2	OF 5
ARCAM. A & R CAMBRIDGE LTD, CB5 9PB				

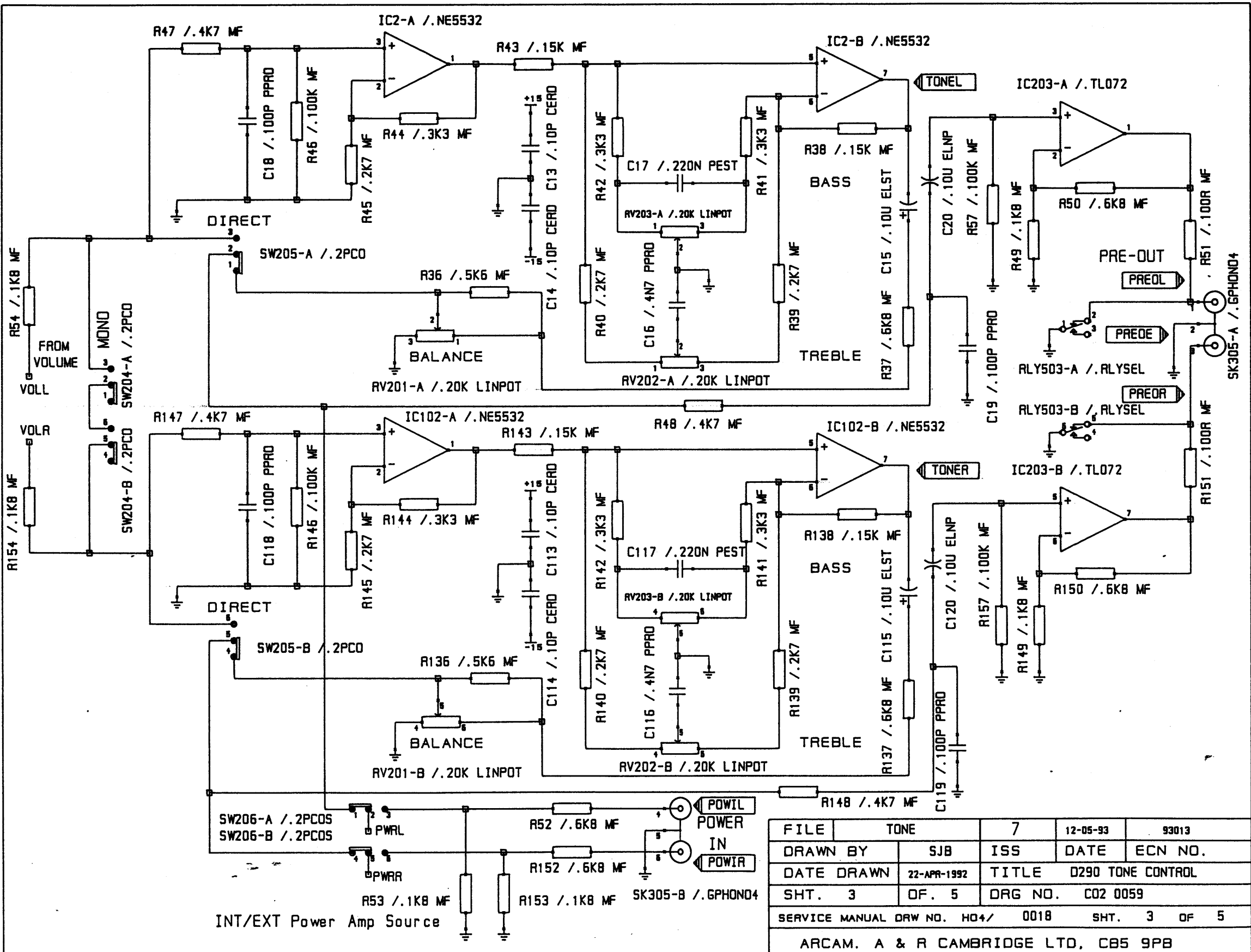

INT/EXT Power Amp Source

FILE	TONE	7	12-05-93	93013
DRAWN BY	SJB	ISS	DATE	ECN NO.
DATE DRAWN	22-APR-1992	TITLE	D290 TONE CONTROL	
SHT. 3	DF. 5	DRG NO.	C02 0059	
SERVICE MANUAL DRW NO. HO4/		0018	SHT. 3	OF 5
ARCAM. A & R CAMBRIDGE LTD, CB5 9PB				

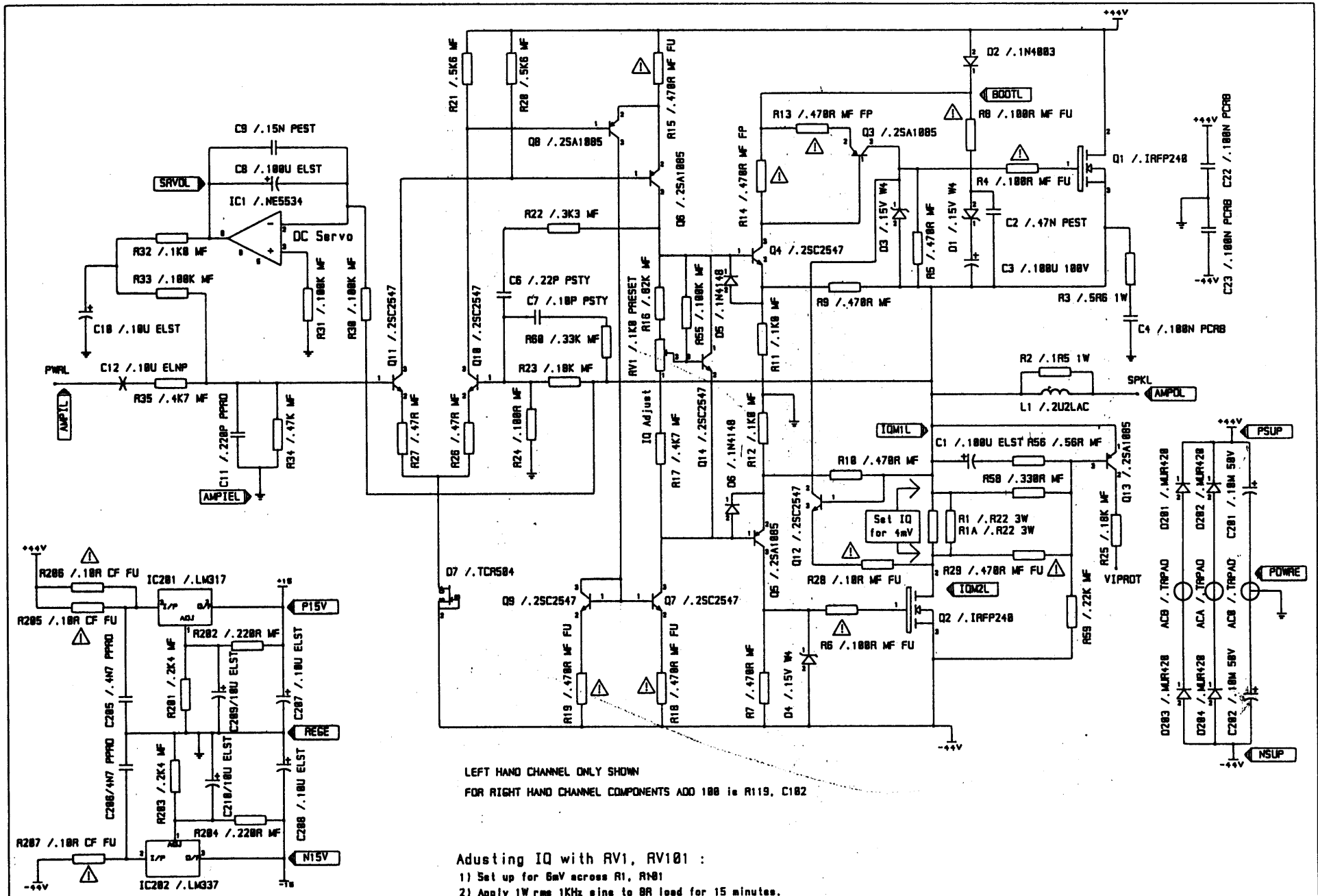

LEFT HAND CHANNEL ONLY SHOWN  
 FOR RIGHT HAND CHANNEL COMPONENTS ADD 100 to R119, C102

- Adjusting IQ with RV1, RV101 :
- 1) Set up for 6mV across R1, R01
  - 2) Apply 1W rms 1KHz sine to 8R load for 15 minutes.
  - 3) Re-set for 4mV across R1, R01

Safety  $\triangle$ : Replace only with same type component.

FILE NAME	MOSFET	8	11-May-1993	93057
DRAWN BY	S.J.Blandford	ISS	DATE	ECN NO.
DATE DRAWN	17-Nov-1991	TITLE	D298 Power Amp & Amp PSU	
SHT.	4	OF.	5	DRG NO. C02 0059
SERVICE MANUAL DRW. NO. H04/ 0018 SHEET 4 OF 7				
ARCAM. A & R CAMBRIDGE LTD, CB5 9PB				

NOTE: For 230V operation fit FS501, T1A6.  
For 115V operation fit FS502, T3A15.  
Only fit ONE fuse.

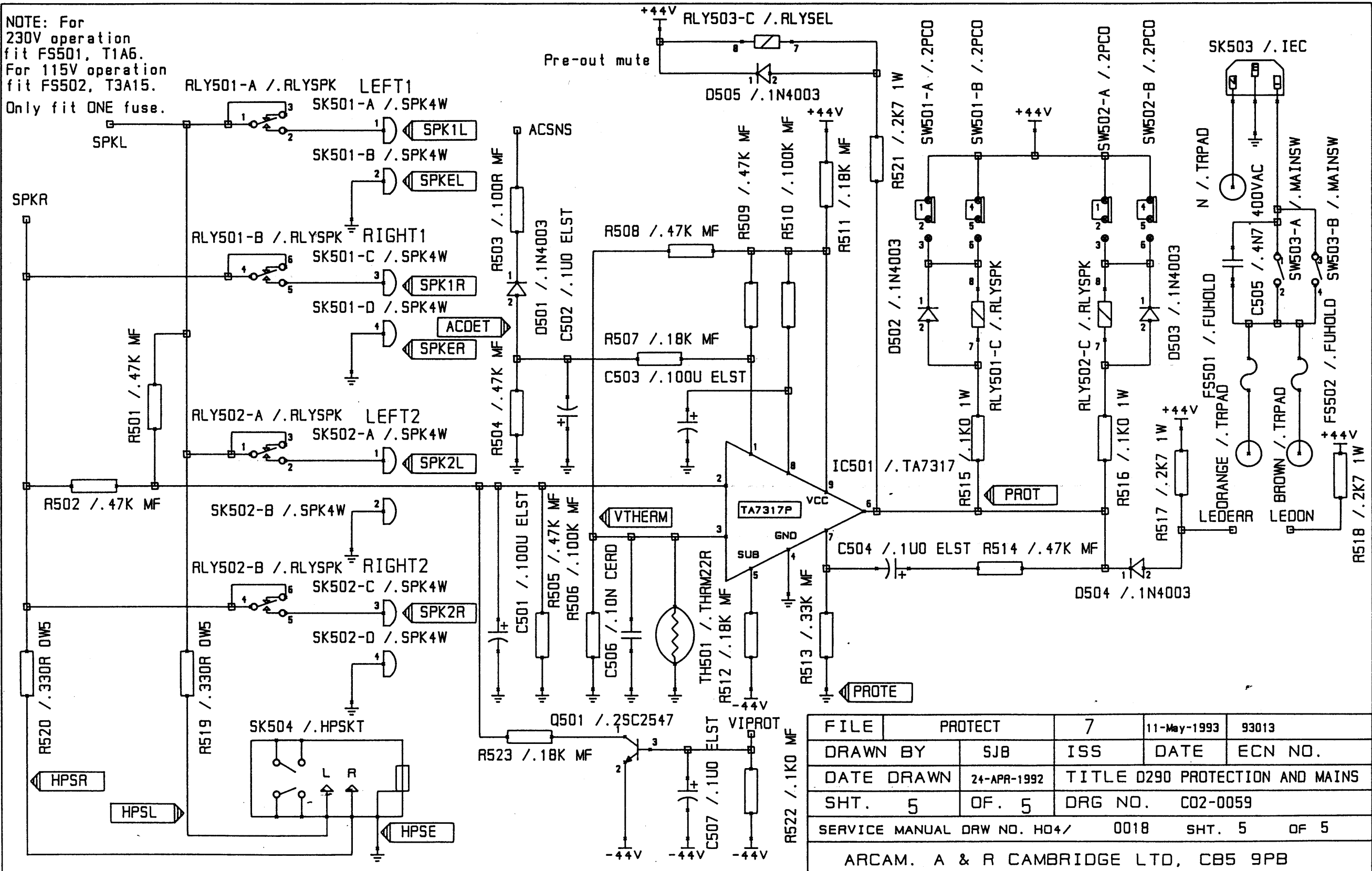

FILE	PROTECT	7	11-May-1993	93013
DRAWN BY	SJB	ISS	DATE	ECN NO.
DATE DRAWN	24-APR-1992	TITLE	D290 PROTECTION AND MAINS	
SHT. 5	OF. 5	DRG NO.	C02-0059	
SERVICE MANUAL DRW NO. HO4/		0018	SHT. 5	OF 5
ARCAM. A & R CAMBRIDGE LTD, CB5 9PB				

# D290 MM / MC PHONO AMPLIFIER

9E0105

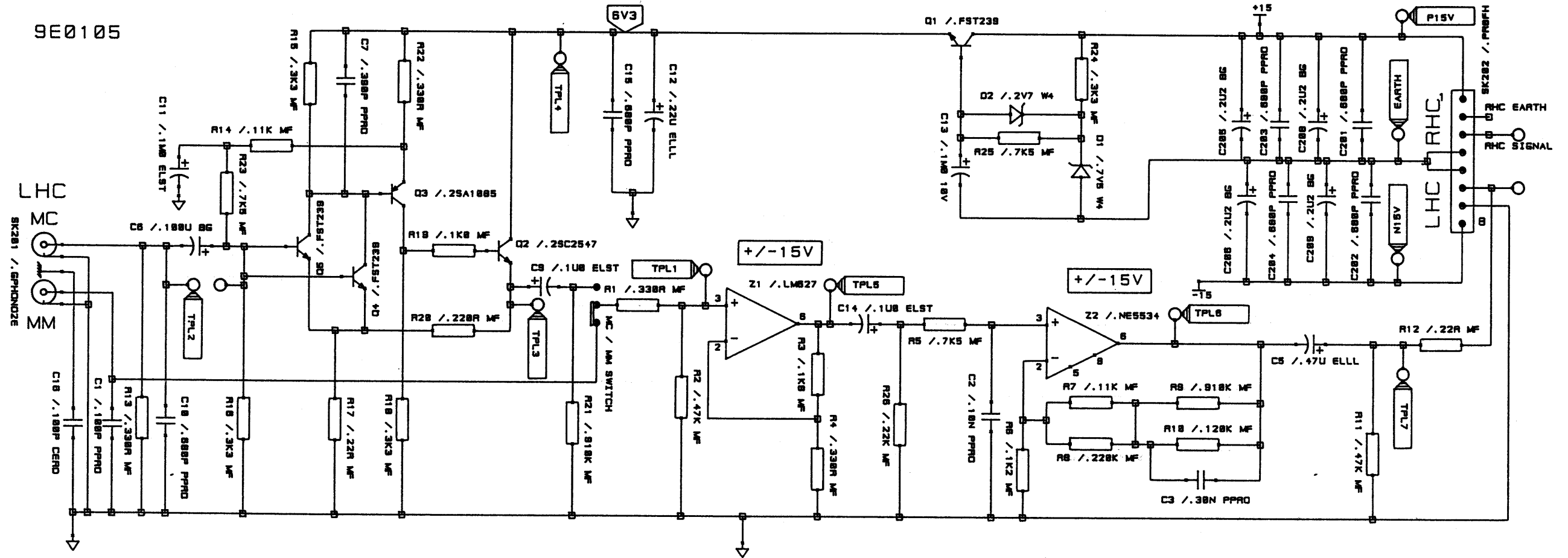

RHC MM / MC DISC AMPLIFIER  
 (RHC ADD 100 ie R101, C101)  
 TEST POINTS = TPR1 etc

FILE NAME	D90MAG1	4	4-1-93	93002
DRAWN BY	JMG	ISS	DATE	ECN NO.
DATE DRAWN	22-4-92	TITLE D90 PHONO AMP STAGE		
SHT.	OF.	DRG NO. CO2_0061		
SERVICE MANUAL DRW. NO. H04/0017 SHEET OF				
ARCAM. A & R CAMBRIDGE LTD, CB5 9PB				

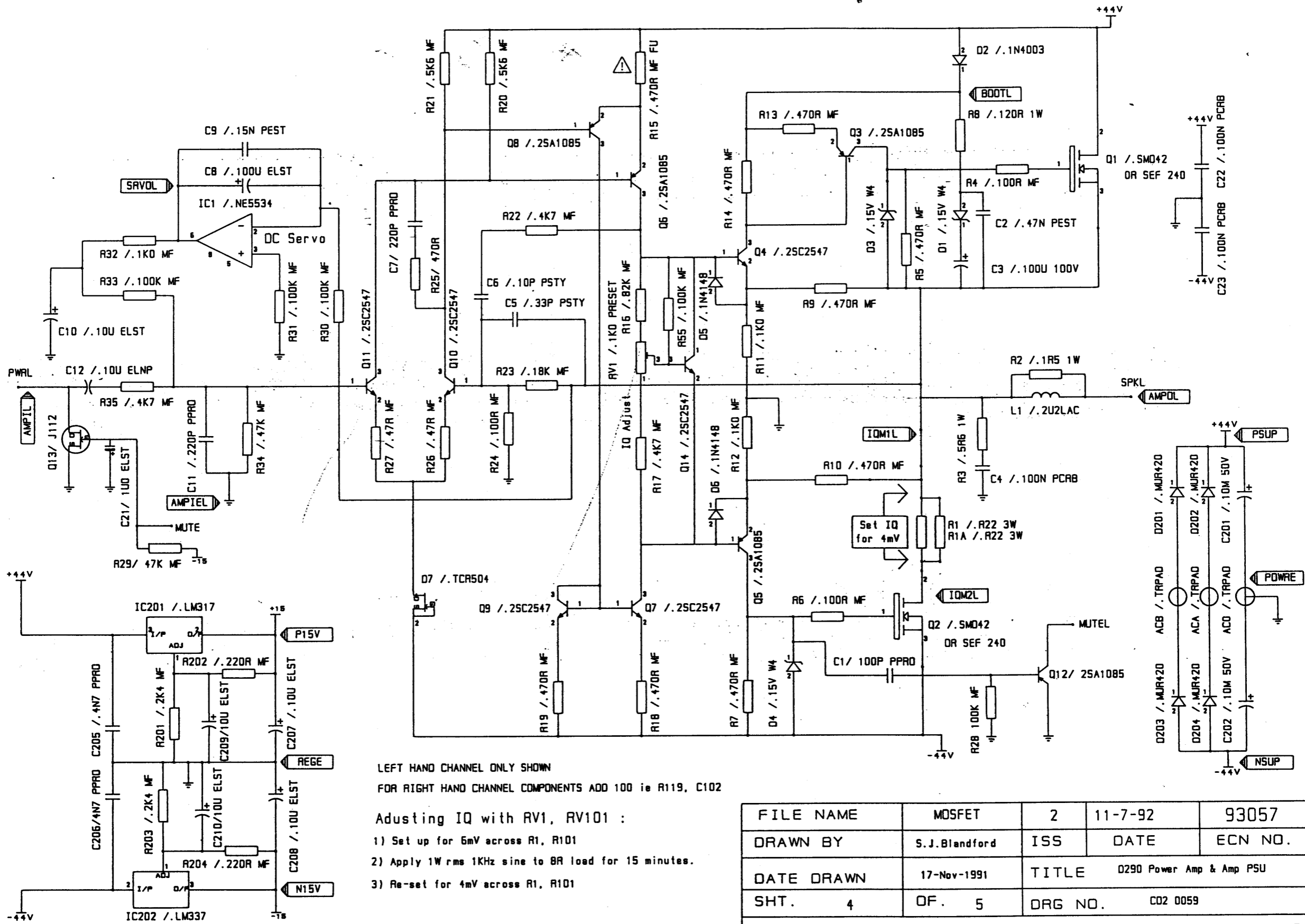

LEFT HAND CHANNEL ONLY SHOWN  
 FOR RIGHT HAND CHANNEL COMPONENTS ADD 100 ie R119, C102

- Adjusting IQ with RV1, RV101 :
- 1) Set up for 5mV across R1, R101
  - 2) Apply 1W rms 1KHz sine to BR load for 15 minutes.
  - 3) Re-set for 4mV across R1, R101

FILE NAME	MOSFET	2	11-7-92	93057
DRAWN BY	S.J.Blandford	ISS	DATE	ECN NO.
DATE DRAWN	17-Nov-1991	TITLE D290 Power Amp & Amp PSU		
SHT. 4	OF. 5	DRG NO.	C02 0059	
SERVICE MANUAL DRW. NO. H04/ 0018 SHEET 7 OF 7				
ARCAM. A & R CAMBRIDGE LTD, CB5 9PB				