

SERVICE MANUAL

XP308I

MODEL NO.: XP308I

Contents

<i>Specification</i>	1-2
<i>Block Diagram</i>	3
<i>Packing View</i>	4
<i>Packing View Part List</i>	5
<i>Point To Point Wiring Diagram</i>	6
<i>Exploded View</i>	7
<i>Exploded View Part List</i>	8-10
<i>Electrical Part List</i>	11-19
<i>Schematic Diagram</i>	20-23
<i>Printed Circuit Board Diagram</i>	24-28
<i>IC Block Diagram</i>	29-34

MIXER PART

NORMAL

LIMIT

*MAXIMUM VOLTAGE GAIN

;MIC IN TO MONITOR L/R		62±3dBm
;MIC IN TO MONITOR L/R(MIC/LINE WITHIN)		32±3dBm
;MIC IN TO AMP OUT (MIC/LINE WITHIN,LIMITER LED JUST LIGHT)		58±3dBm
;MONO LINE IN TO MONITOR L/R		20±3dBm
;ST LINE IN TO MONITOR L/R		28±3dBm
;MONO MIC IN TO REC OUT		38±3dBm

*FREQUENCY RESPONSE (20HZ~20KHZ)

(LEVER VR NORMAL, MONITOR VR NORMAL OUTPUT LEVEL +4dBm)

;MIC IN TO MONITOR L/R		±2dB
;LINE IN TO MONITOR L/R		±2dB
;LINE IN TO REC L/R		±2dB

*MAXIMUM OUTPUT LEVEL

(OUTPUT LOAD 10K ohm,Before just clipping)

;MIC IN TO MONITOR L/R	21 dBm	more than 20dBm
------------------------	--------	-----------------

*T.H.D

(LEVEL , MONITOR VR NOMINAL, OUTPUT +14dBm, OUTPUT LOAD 10K ohm 80KHz LPF)

;MIC IN TO MONITOR L/R		LESS than 0.1%
;LINE IN TO MONITOR L/R		LESS than 0.1%

*HPF

(SPEECH/MUSIC ON 75Hz MONITOR OUTPUT)

-3dB±1

*TONE CONTROL

(CH LEVEL ,MONITOR VR NORMINAL,OUTPUT +4dBm)

;10KHZ	±12dB	±12±3dB
;100HZ	±12dB	±12±3Db

NORMAL **LIMIT**

***RESIDUAL NOISE**

(20KHz LPF , AVG)

A) INPUT,OUTPUT LEVEL VR MINIMUM
MONITOR OUT

LESS THAN -90 dBm

B) ONLY MONITOR VR MAXIMUM
MONITOR OUT

LESS THAN -70 dBm

***CROSSTALK**

(CH LEVEL VR & MONITOR VR NORMAL,OUTPUT 20dBm , FREQ 1KHz , 80KHz LPF)

CH VS CH

LESS THAN -67 dB

INPUT VS OUTPUT

LESS THAN -70 dB

***LEVEL METER (0VU)**

21±2dBm

***PHANTOM POWER**

15±1V

***ECHO**

AMP PART

***RATED OUTPUT POWER (MASTER VR NORMAL, CH LEVEL VR TO RATED POWER,600Ω LOAD)**

; 8 OHM @ 1KHZ, 5%THD (LPF 20KHz) (ONE CH)

100W

More than 95W(no clipping)

***LIMITER (CH LEVEL VR & MASTER VR NORMAL)**

(AMP OUTPUT)

105W

LESS than 110W,no clipping

RATED Ouput,Again add 20dBm,Amp Output No Clipping

***FREQUENCY RESPONSE**

8ohm load,Output 1W

6dB±2@50Hz, ±3dB@20kHZ

Remark:

1. If check we want to output test signal from the analyzer(VP-7723B),please parallel a 600 ohm Load from the output signal.
- 2.. The low pass filter should be 20KHz while testing the part of Amp.

3

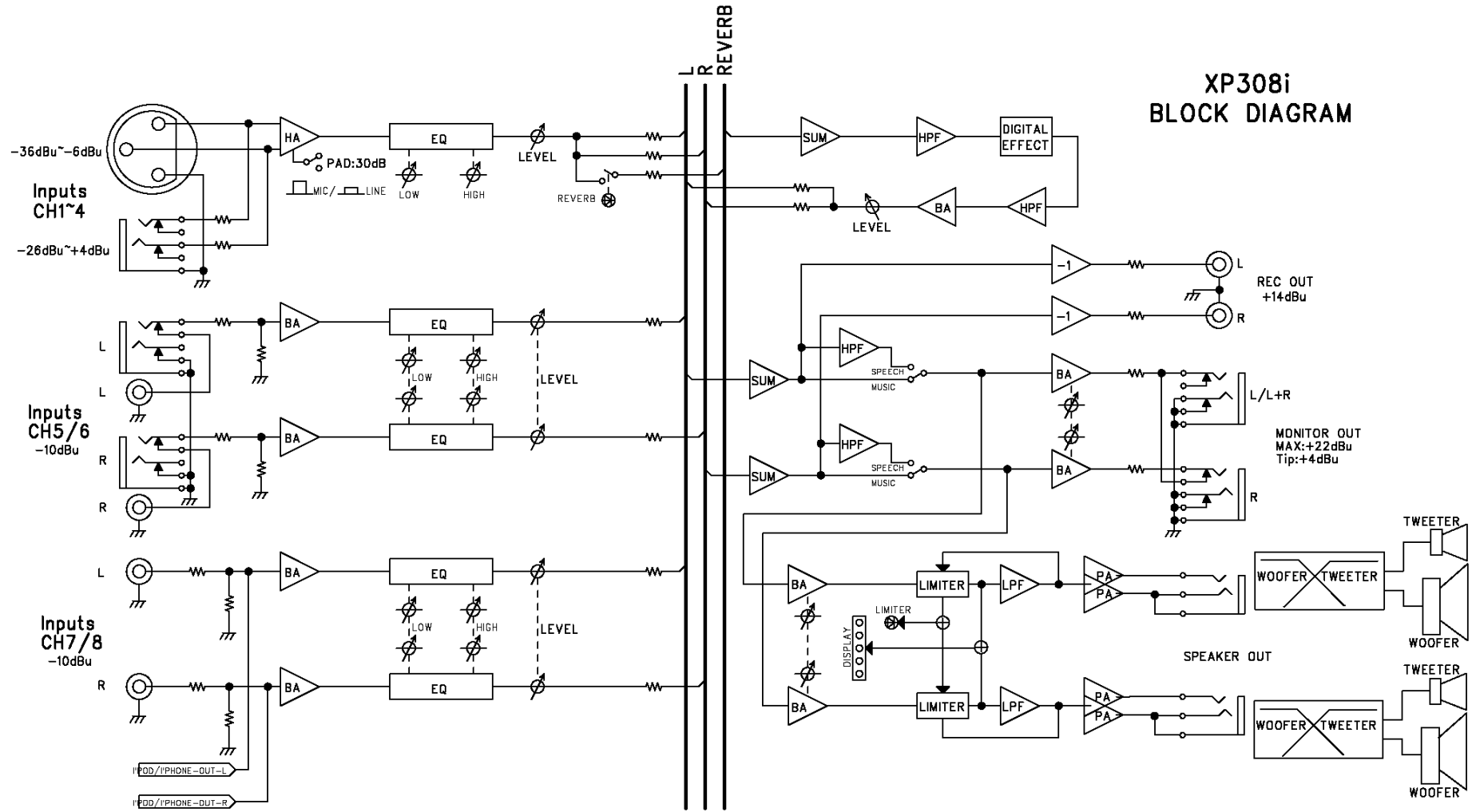

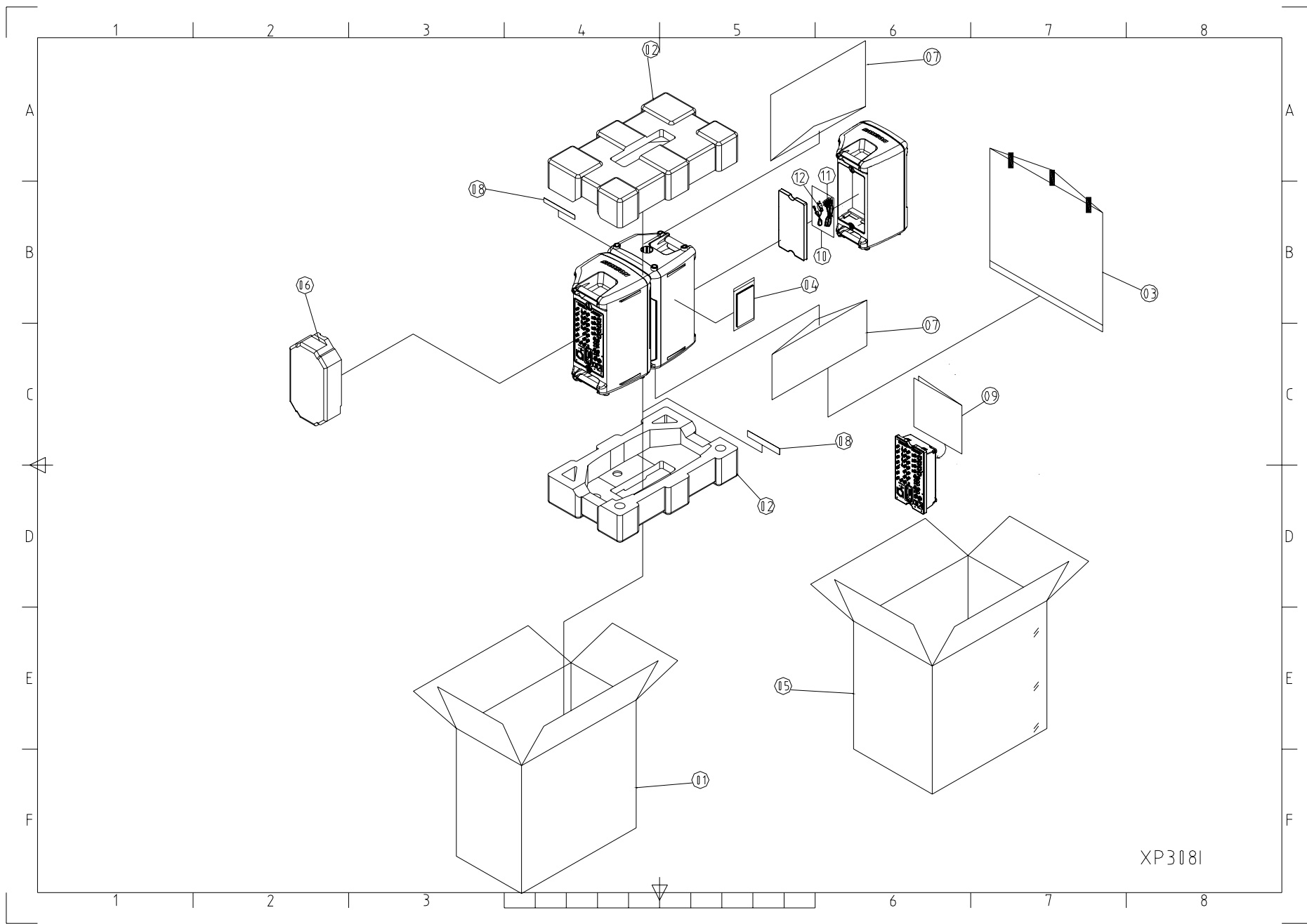

XP3181

Point To Point Wiring Diagram

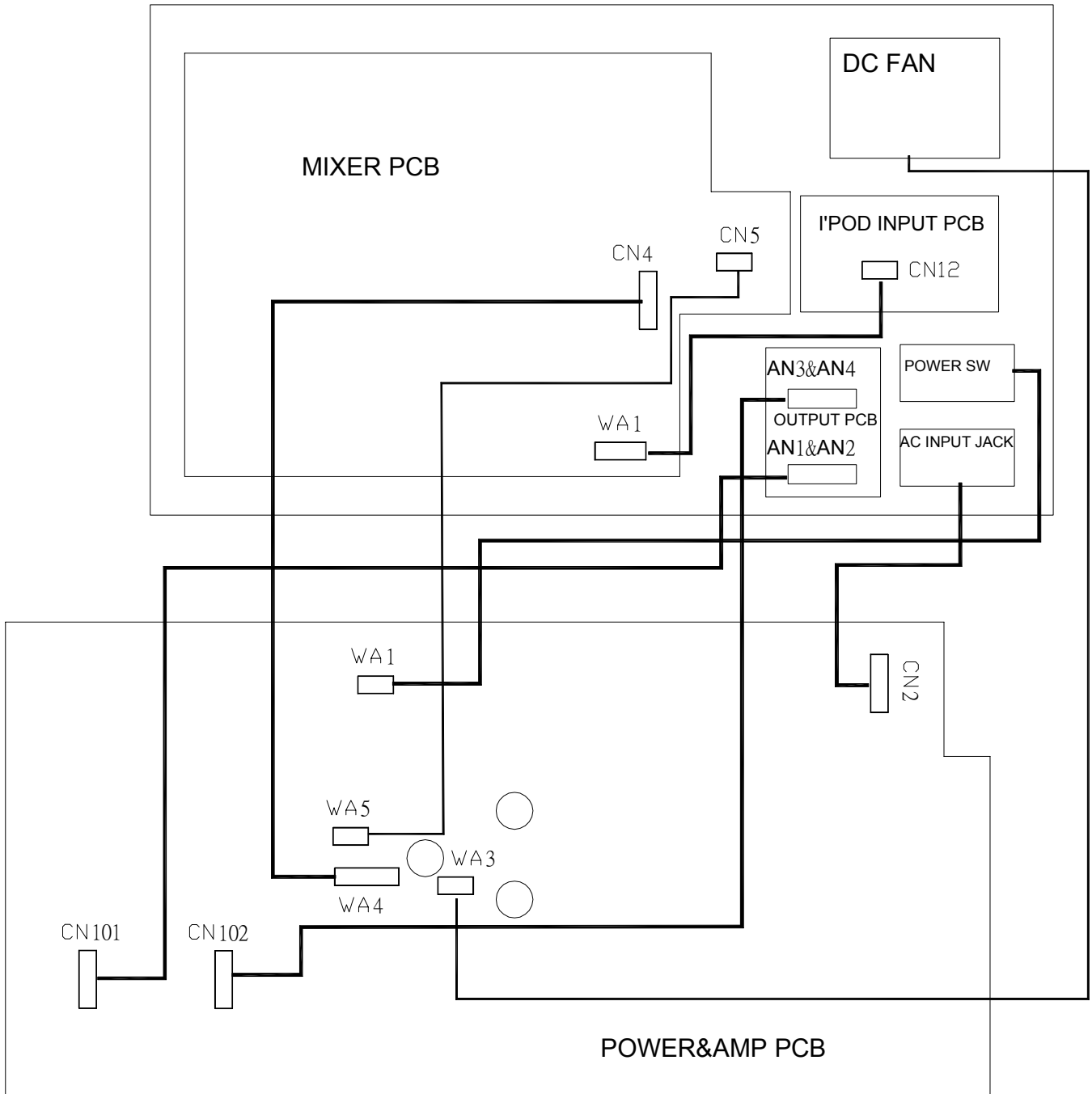

Exploded View

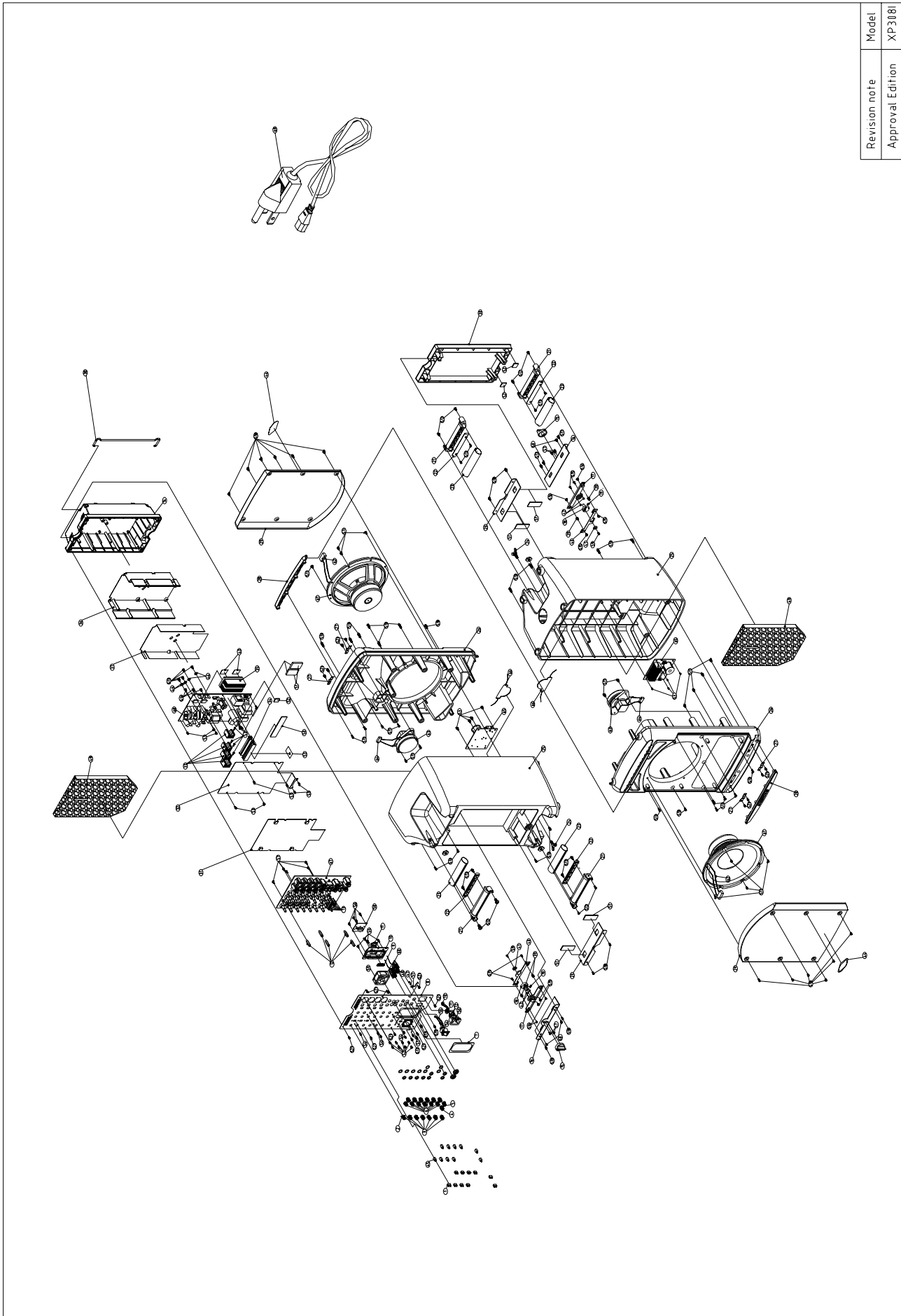

Revision note	Model
Approval Edition	XP3181

Exploded View Part List

REF NO.	DESCRIPTION	PART NO.	Q'TY	REMARK
1	PUSH KNOB	100-L2400-2569	10	
2	CONTROL KNOB(B)	100-XM610-2217	21	
3	KNOB CAP(WHITE)	100-XM610WHT-2218A	7	
4	KNOB CAP(RED)	100-XM610RED-2218A	1	
5	KNOB CAP(BLU)	100-XM610BLU-2218A	1	
6	KNOB CAP(SLIVE)	100-XM610SIL-2218A	12	
7	INLAY	501-STAGE-2167	1	
8	PANEL ASS'Y	703-STAGE-1235	1	
9	CARD CHASSIS	100-XP300-2517	1	
10	TOP DOCK	100-XP300-2503	1	
11	IPOD BUTTON	100-XP300-2504	1	
12	SUPPORT	200-L1200-589	5	
13	LED HOLDER	504-BD1550-067	12	
14	AMPLIFIER CASE ASS'Y	701-XP308I-1243S	1	
15	CONTROL KNOB	100-STAGE-2625	2	
16	REAR PAD(A)	300-STAGE-1672	2	
17	REAR BRACKET	300-STAGE-1674	2	
18	SHAFT	200-SP300-583	2	
19	WASHER	606-B300-030	2	
20	REAR PAD(B)	300-STAGE-1673	2	
21	HANDLE	100-STAGE-2623	4	
22	HANDLE COVER	100-STAGE-2624	4	
23	HANDLE PAD	604-STAGE-496	4	
24	SCREW THUMB	601-EX250-038	2	
25	REAR CASE ASS'Y	701-STAGE-4438	2	
26	FRONT CASE	100-STAGE-2630	2	
27	SPRING SHEET	300-XP308I-1706	4	
28	SLIDE	100-STAGE-2622	2	
29	GRILL	300-STAGE-1675	2	
30	REAR COVER	100-STAGE-2628	1	
31	INSULATION SHEET	501-SP300-2182	1	
32	SHIELD FENCE	300-SP300-1685	1	
33	HEATSINK	425-KMD3500-016A	4	
34	HEAT SINK ASS'Y	703-SP308-1240	1	
35	HEAT SINK	425-STAGE-123	1	
36	BOTTOM INLAY	300-SP300-1684	1	
37	INSULATION SHEET	501-SP300-2181	1	
38	FILP FOOT	603-SP300-377	1	
39	HOOK GUIDE	200-STAGE-578	4	
40	HOOK	300-SP300-1683	2	
41	BOTTOM BRASS	200-SP300-582	2	
42	CAM GUIDE	200-XP308I-586	4	
43	MICA	501-TST4-2028	2	

Exploded View Part List

REF NO.	DESCRIPTION	PART NO.	Q'TY	REMARK
44	SAMSON LOGO	501-XP308I-2205	2	
45	KNOB NECK	100-XP308I-2649	10	
46	WASHER	606-LC58FA-130	4	
47	TOOTH WASHER	606-F200-002	1	
48	NUT	601-F200-001	1	
49	COTTON	509-XP308I-252	2	
50	EVA	612-XP308I-322	1	
51	EVA	612-XPL200-293	6	
52	EVA	612-XP308I-323	3	
53	SILICONE SHEET	612-XP308I-324	1	
54	POWER SW	403-DJ1-107A	1	
55	2P 3.96CON ASS'Y(UL1007#18,RED*2,L=200mm)	404-XPL200-2679	1	
56	AC INPUT JACK	420-SX1800-195	1	
57	1P CONNECTOR WIRE(L=80MM,UL1015#18)	406-XP308I-1088	1	TO AC INPUT JACK "GND"
58	I'POD INPUT PCB ASS'Y	704-XPL300-7193	1	
59	DC FAN	401-XP308I-076	1	
60	OUTPUT PCB ASS'Y	704-XP308I-8289	1	
61	WOOFER SPEAKER(WOOFER 8Ω/75W,8")	419-XP308I-065	2	
62	3P CONNECTOR WIRE(L=550mm,UL1430#18 TS RED/BLACK)	404-XPL200-2775	2	
63	TWEETER SPEAKER(8Ω 20W ∅ 25)	419-XP308I-066	2	
64	3P CON ASS'Y(UL1430#18,BULE BLACK,L=550mm)	404-XPL100-2676	2	
65	SPEAKER TWO FREQUENCY PCB ASS'Y	704-XP308I-8251	2	
66	SPEAKER INPUT PCB ASS'Y	704-XP308I-8347	2	
67	MIXER PCB ASS'Y	704-XP308I-8285	1	
68	POWER& PCB ASS'Y	704-XP308I-8286	1	
69	AC CORD(L=1900 18AWG LP-31 SJT LS-13)	409-XM910-121	1	
70	2P CONNECTOR(L=170mm UL1617#18 P=3.96mm)	404-XP308I-3148A	1	TO AC INPUT JACK "N"
71	FERRITE CORE	415-F806-264	1	
72	SAFETY CAPACITOR(2200pF/250VAC,M,Y5U,Y2,TAPING)	413-XP308I-1148	2	
S1	SCREW TTB 4*10	602-PTPB4010-665	2	
S2	SSCREW(3*8mm TTB)	602-2002-077	8	
S3	SCREW TTB3*8	602-XM610-528	24	
S4	SCREW M2.6*6	602-XM610-514	5	
S5	SCREW M2*5	602-DD2220-301	4	
S6	SCREW 2.6*6	602-KMD510-158	4	
S7	SCREW 2.6*6	602-ISOB2606-654	9	
S8	SCREW M3*6	602-SX1200-544	4	
S9	SCREW BM4*8	602-CDVD2001-351	2	
S10	SCREW	602-TTB5024-668	22	
S11	SCREW TTB 4*16	602-BTTB4016-676	20	
S12	SCREW M6*16	602-PISO6016-667	8	

Mixer PCB Ass'y Part List

REF NO.	DESCRIPTION	PART NO.	Q'TY	REMARK
	MIXER PCB ASS'Y	704-XP308I-8285	1	
	SUPPORT(BRASS)	200-L1200-589	5	
SW1,SW2,SW3,SW4,SW5,SW6,SW7,SW8,SW9,SW10	PUSH SW(SPPH2-001-E)	403-XM910-203	10	
WA1	7P SOCKET(CKM2501WV-7P 180°WHITE)	404-DV300-507A	1	
CN4	7P CON ASS'Y(P=2.0mm L=350mm UL1007#26,+/+)	404-XP308I-3145	1	
CN5	2P ASS'Y CON (P=2.0mm L=350mm UL1007#26,+/+)	404-XP308I-3163	1	
LD6,LD6H	LED (6224-10ID-A,RED)	410-CD6000-122	2	
LD3H,LD4H,LD5H	LED (YELLOW)	410-CD6000-123	3	
LD1H,LD2H,LD1A,LD1B,LD1C,LD1D	LED (GREEN)	410-CD6000-124	6	
LD7H	LED(BLUE)	410-HPA5000-274	1	
R23G	METAL RES(330OHM,1W,J,T-63)	412-CS8011B-415	1	
R67H	METAL OXIDE RESISTOR(180 OHM,1W J AXIAL TAPING 74mm)	412-XM910-870	1	
SVR2,SVR3	VRES(TB655MCL-1K/NP 6ψ)	412-XP200-1227	2	
C31H,C40H,C21H,C22H,C25H	ELEC. CAPACITOR(100uF/25V,M,105°C,TAPING 6.3*11)	413-HS100-180	5	
C48H,C19H,C29H,C37H	ELEC. CAPACITOR (47uF/25V M 105°C, TAPING 5*11)(Cd,Pb,Hg,Cr)	413-HS100-181	4	
C23H,C24H	ELEC.CAP(22uF/50V,NP,M,TAPING 8*12)	413-SX2800-910	2	
U18	IC(KA2284B)	417-XM910-779	1	
VR1,VR2,VR4,VR5,VR7,VR8,VR10,VR11	VR(XV09213YNPV30F1B50KCC(50K*1))	418-TXM20-359	8	
VR3,VR6,VR9,VR12,VR21	VR(XV09213YNPV30F15A20K(20K*1))	418-TXM20-362	5	
VR13,VR14,VR17,VR20	VR(XV012313YGPV30F(20K*2))	418-TXM20-363	4	
VR15,VR16,VR18,VR19	VR(XV012313YGPV30F1B50KCC(50K*2))	418-TXM20-365	4	
JK15	4P RCA JACK(RCA-406B/P)	420-TXM20-236	1	
JK2,JK4,JK6,JK8,JK10,JK13,JK11,JK12	PHONE JACK(JY-6351G*02-250)(Cd,Pb)	420-XM910-178A	8	
JK9	RCA JACK/2P/VERTICAL(AV2-8.2-32B SONGCHENG)	420-XM910-180	1	
JK1,JK3,JK5,JK7	3P MIC JACK FEMALE(JY-5033*030)	420-XP200-275	4	
	LED HOLDER(LED-21,H=21mm)	504-BD1550-067	12	
	SCREW(M2.6,L=6mm,C-1018)	602-ISOB2606-654	5	
TO CN4,CN5 WIRE	HEAT-SHRINKABLE TUBE	605-HDJ201F-050	0	
R11H,R16H,R17H,R2H	CHIP RESISTOR(18K OHM 1/8W 0805 J TP 150V)	412-AMC110D-5057	4	
R29H,R35H,R75H	CHIP RESISTOR(1.8K OHM,1/8W,0805,J,TP ,150V)	412-AMC110D-5061	3	
R18G	CHIP RESISTOR(5.6K OHM,1/8W, 0805,J,TP 150V)	412-CDMIX1-456	1	
R24H,R38H	CHIP RESISTOR(680K OHM,1/8W,0805,J,TP ,150V)	412-CDN88-024	2	
R1E,R1F,R25H,R2E,R2F,R48H,R7H,R9H	CHIP RESISTOR(100 OHM,1/8W,J,0805,150V)	412-DV330-304	8	
R69H,R71H	CHIP RESISTOR(1K OHM,1/8W, 0805,J,TP 150V)	412-DV330-305	2	

Mixer PCB Ass'y Part List

REF NO.	DESCRIPTION	PART NO.	Q'TY	REMARK
R11E,R11F,R16F,R17F,R18F,R18H,R20A,R20B,R20C,R20D,R20G,R21A,R21B,R21C,R21D,R22A,R22B,R22C,R22D,R2G,R3E,R3F,R3G,R44H,R4E,R4F,R5E,R5F,R9G,R12F,R13E,R13F,R14E,R14F,R16A,R16B,R16C,R16D,R17A,R17B,R17C,R17D,R18A,R18B,R18C,R18D,R7E,R8E,R8F,R9E,R24G,R16E,R12E,R7F,R9F,R6E,R6F,R76H,R77H,R78H,R79H,R80H,R81H,R21H,R40H	CHIP RESISTOR(10K OHM,1/8W,0805,J,TP 150V)	412-DV330-306	65	
R23H,R27H,R33H,R47H,R7G,R61H	CHIP RESISTOR(100K OHM,1/8W, 0805,J,TP 150V)	412-DV330-307	6	
R13H,R5H,R22G,R22H,R46H,R14H,R42H,R1G	CHIP RESISTOR(20K OHM,1/8W,0805,J,TP ,150V)	412-DV330-311	8	
R12H,R4H	CHIP RESISTOR(22K OHM,1/8W, 0805,J,TP 150V)	412-DV330-314	2	
R17G	CHIP RESISTOR(3K OHM,1/8W, 0805,J,TP 150V)	412-DV330-316	1	
R12G,R14G,R4G,R6G	CHIP RESISTOR(3.3K OHM,1/8W, 0805,J,TP,150V)	412-DV330-317	4	
R15E,R15F,R17E,R19A,R19B,R19C,R19D,R19F,R26H,R39H,R11G	CHIP RESISTOR(4.7K OHM,1/8W,0805,J,TP 150V)	412-DV330-320	11	
R12,R13G,R3H,R5G,R57H,R51H,R15G,R16G	CHIP RESISTOR(47K OHM,1/8W,0805,J,TP 150V)	412-DV330-321	8	
R31H,R37H	CHIP RESISTOR(680 OHM,1/8W, 0805,J,TP 150V)	412-DV330-323	2	
R10G,R30H,R36H	CHIP RESISTOR(12K OHM,1/8W, 0805,J,TP,150V)	412-DV330-330	3	
R19G,R21G,R8G,R59H	CHIP RESISTOR(15K OHM,1/8W,0805,J,TP 150V)	412-DV330-331	4	
R52H,R53H,R56H,R58H	CHIP RESISTOR(560 OHM,1/8W, 0805,J,TP,150V)	412-DV330-336	4	
R50H,R55H	CHIP RESISTOR(56K OHM,1/8W,0805,J,TP ,150V)	412-DV330-337	2	
R20H,R41H	ROHS,CHIP RESISTOR(75K OHM,1/8W,J,TP 0805,150V)	412-HP6000-851	2	
JR1,JR2,JR3,JR4,JR5,JR6	CHIP RESISTOR (0 OHM,1/8W,0805,J,TP 150V)	412-HV3500K-367	6	
R49H,R54H	CHIP RESISTOR(9.1K OHM,1/8W,J,TP 0805,150V)	412-M5-574	2	
R3A,R3B,R3C,R3D,R4A,R4B,R4C,R4D	CHIP RESISTOR(10 OHM 0805 1/8W +/-1%)	412-MX1436-786	8	
R19H,R45H	CHIP RESISTOR((68 OHM,1/8W,J,TP 0805,150V)	412-PS2-659	2	
R32H,R62H,R63H,R64H,R65H,R66H,R72H,R70H,R68H	CHIP RESISTOR (1.5K OHM,1/8W, 0805,J,TP,150V)	412-QMX1-035	9	
R74H	CHIP RESISTOR(5.1K OHM,1/8W, 0805,J,TP,150V)	412-QMX2-188	1	
R15H,R43H	CHIP RESISTOR(39K OHM,1/8W,0805,J,TP 150V)	412-QMX2-192	2	
R60H,R1H,R10H	CHIP RESISTOR(43K OHM,1/8W,J,TP 0805,150V)	412-SA12-657	3	
R7A,R7B,R7C,R7D,R8A,R8B,R8C,R8D	CHIPRESISTOR(2.4KOHM,1/8W,F,0805,150V,TP)	412-XP308I-1377	8	
R5A,R5B,R5C,R5D,R6A,R6B,R6C,R6D	CHIPRESISTOR(47KOHM,1/8W,F,0805,150V,TP)	412-XP308I-1378	8	
R25A,R25B,R25C,R25D,R26A,R26B,R26C,R26D	CHIPRESISTOR(4.7KOHM,1/8W,F,0805,150V,TP)	412-XP308I-1379	8	

Mixer PCB Ass'y Part List

REF NO.	DESCRIPTION	PART NO.	Q'TY	REMARK
R9A,R9B,R9C,R9D,R10A,R10B,R10C,R10D	CHIPRESISTOR(1.8KOHM,1/8W,F,0805,150V,TP)	412-XP308I-1380	8	
R11A,R11B,R11C,R11D,R12A,R12B,R12C,R12D	CHIPRESISTOR(3.9KOHM,1/8W,F,0805,150V,TP)	412-XP308I-1381	8	
R13A,R13B,R13C,R13D,R14A,R14B,R14C,R14D,R15A,R15B,R15C,R15D,R24A,R24B,R24C,R24D	CHIPRESISTOR(220KOHM,1/8W,F,0805,150V,TP)	412-XP308I-1382	16	
C34H,C39H	CHIP CAPACITOR(47pF/50V,J,0805 TYPE,NPO)	413-AMC110D-5094	2	
C18H,C26H,C7A,C7B,C7C,C7D,C8A,C8B,C8C,C8D	CHIP CAPACITOR(220pF/50V,J,0805 TYPE,NPO)	413-AMC110D-5104	10	
C2G,C17H,C27H,C60H,C61H	CHIP CAPACITOR(22pF/50V,J,0805 TYPE,NPO)	413-CDN88-080	5	
C11E,C11F,C14A,C14B,C14C,C14D,C15A,C15B,C15C,C15D,C16E,C16F,C20A,C20B,C20C,C20D,C3G,C3H,C9H	CHIP CAPACITOR(10pF/50V,J,0805 TYPE,NPO)	413-DV330-309	19	
C1E,C1F,C20H,C2E,C2F,C30H,C5E,C6E,C6F,C36H,C41H,C46H,C47H,C5F	CHIP CAPACITOR(100pF/50V,J,0805 TYPE,NPO)	413-DV330-310	14	
C33H,C38H	CHIP CAPACITOR(1000pF/50V,J,0805 TYPE,NPO)	413-DV330-311	2	
C21A,C21B,C21C,C21D	CHIP CAPACITOR(0.01uF/50V,K,0805 TYPE,X7R)	413-DV330-312	4	
C28G,C29G,C20G,C21G,C23G,C19E,C20E,C21E,C22E,C23C,C24C,C50H	CHIP CAPACITOR(0.1uF/50V,Z,0805 TYPE,Y5V)	413-DV330-313	12	
C10E,C10F,C13E,C13F,C14E,C14F,C17A,C17B,C17C,C17D,C18A,C18B,C18C,C18D,C9E,C9F	CHIP CAPACITOR(0.022uF/50V,K,0805 TYPE,X7R)	413-DV330-317	16	
C15G	CHIP CAPACITOR(0.033uF/50V,K,0805 TYPE,X7R)	413-DV330-321	1	
C7G	CHIP CAPACITOR(5600pF/50V,K,0805 TYPE,X7R)	413-DV330-324	1	
C1A,C1B,C1C,C1D,C2A,C2B,C2C,C2H,C42H,C2D	CHIP CAPACITOR(330pF/50V,J,0805 TYPE,NPO)	413-DV330-328	10	
C16G,C17G,C8G	CHIP CAPACITOR(560pF/50V,J,0805 TYPE,NPO)	413-DV330-331	3	
C18G,C19G	CHIP CAPACITOR(0.047uF/50V,K,0805 TYPE,X7R)	413-HDJ9500-458	2	
C10A,C10B,C10C,C10D,C13A,C13B,C13C,C13D,C9A,C9B,C9C,C9D	CHIP CAPACITOR(150pF/50V,J,0805 TYPE,NPO)	413-HV3500K-353	12	
C27A,C27B,C27C,C27D,C27E,C27F,C28A,C28B,C28C,C28D,C28E,C28F,C29E,C29F,C30E,C30F	CHIP CAPACITOR(4700PF/50V,1206,K,5%,X7R,TAPING)	413-XP308I-1150	16	
D513,D514,D515,D518,D519,D520,D1A,D1B,D1C,D1D,D2A,D2B,D2C,D2D,D3A,D3B,D3C,D3D,D4A,D4B,D4C,D4D	SMD DIODE(LL4148 AXIAL TYPE L=3.8mm)	414-CDVD2003-139	22	

Power & Amp PCB Ass'y Part List

REF NO.	DESCRIPTION	PART NO.	Q'TY	REMARK
	POWER& PCB ASS'Y	704-XP308I-8286	1	
WA4	7P SOCKET(P=2.0mm, JAE)	404-CDN34A-702	1	
WA5	2P SOCKET(CKM2001WV-2P, 180°WHITE)	404-HP1010K-257A	1	
CN2	3P SOCKET(CKM3962WV-3P, 180°WHTIE PIN2 NC)	404-Q2131-2218	1	
CN101,CN102,WA1	2P BASE(P=3.96mm CKM3962WV-2P)	404-XM610-1788	3	
WA3	2P BASE(CKM2503WV-2P, 180°WHITE)	404-XM910-1833	1	
T3	Transformer(XH11-A19001-851)	411-XP308I-742	1	
T1	Transformer	411-XP308I-743	1	
T2	Transformer(ERL-3541B7 6000WH±10%)	411-XP308I-744	1	
R16,R17	CARBON FILM RESISTOR(82K OHM, 1/4W, J, T-26)	412-3113-081	2	
R71,R72,R54,R55	METAL FILM RESISTOR(10 OHM, 1W J T-73)	412-DCM280-720	4	
R2,R3	CARBON FILM RESISTOR(620K OHM J 1/6W BULK M-TYPE)	412-HMA2200-5008	2	
R99,R100,R109,R110	CARBON FILM RESISTOR(22 OHM, 1W, J, T-73)	412-HV3363K-350	4	
R97,R98,R107,R108	CARBON FILM RESISTOR(10 OHM, 1/2W, J, T-52)	412-SA12-566	4	
R1	METAL OXIDE RESISTOR(180 OHM, 1W J AXIAL TAPING 74mm)	412-XM910-870	1	
R10	Resistor(0.12OHM 1W J)	412-XP308I-1354	1	
R19,R32	Resistor(47KΩ, 1W, J, T-73/BOX)	412-XP308I-1358	2	
VR1	TVR(TVR10471 THINKING)	412-XP308I-1361	1	
TH1	NTC(10Ω, SCK15105MIY)	412-XP308I-1367	1	
C20,C18	E.C(1000uF/50V Z, 105°C, 10*26mm BULK)(Cd,Pb,Hg,Cr)	413-EG110-630	2	
D101 -	POLYESTER CAPACITOR(0.1uF/100V, J, TAPING)	413-KT350-089	1	
C38	METAL POLYESTER CAPACITOR(0.12uF/50V, J, TAPING)	413-M2-763	1	
CA,CB,CC,CD	POLYESTER CAPACITOR(0.1uF/63V, J, TAPING)	413-SPPW3-083	4	
C162	METAL POLYESTER CAPACITOR(0.68uF/100V J TAPING)	413-SZ480-1031A	1	
C19,C21	ELEC. CAPACITOR(470uF/50V 105°C 10*21)	413-TXM20-988	2	
C136,C178	E.C(470uF/63V M 105°C BULK 13*25mm)	413-XM910-923	2	
C11	ELEC CAPACITOR(120uF/450V, M, 35*22)	413-XP308I-1127	1	
C3,C4	Safety CAPACITOR(0.1uF, K, 400V, DC STRONG)	413-XP308I-1128	2	
C7	Safety CAPACITOR(1uF K 400VDC STRONG)	413-XP308I-1130	1	
C5,C6	SAFETY CAPACITOR(2200pF/250VAC, M, Y5U, Y2, TAPING)	413-XP308I-1148	2	
C24,C25	SAFETY CAPACITOR(2200pF/400VDC, M, Y5U, Y1, TAPING)	413-XP308I-1149	2	
ZD2	ZENER DIODE(MTZJ3.9-B, 1/2W, T-77)	414-DV300-5012	1	
ZD5	ZENER DIODE(18V 1W, IN4746A)	414-RB2030-230	1	
D1	ULTRAFast DIODE(UF5408 TAPING VISHAY)	414-XP308I-275	1	
D3,D5	DIODE(UF4007 DO-41 VISHAY)	414-XP308I-277	2	
D8,D15,D17	DIODE(1N4937, 1W, T=52mm, DO-41 CAMBRIDGE)	414-XP308I-278	3	
D10	SCHOTTKY BARRIER DIODE(SR306 DO-201AD T-52 TAIWAN SEMI)	414-XP308I-279	1	
BD1	BRIDGE DIODE(KBJ1006 TS-6P CAMBRIDGE)	414-XP308I-283	1	
L105	BEAD CORE(TB36-863445NP T-26mm)	415-HV3500K-090	1	
L103,L104,L107,L108	INDUCTOR(22uH)	415-SZ480-289	4	
L2	COIL(4.2uH, 11* ∅ 7.5mm, XH11-R06011-3R3)	415-XP308I-329	1	
L3,L4	COIL(10.5uH, 25.5*107mm, XH11-R06010-100)	415-XP308I-330	2	
LF1,LF2	LINE FILTER(14mH*2 <19.5*11mm>, XH11-L28004-143)	415-XP308I-331	2	
Q1	Transistor(KTN2222A NPN TO-92 KEC)	416-XP308I-350	1	
Q4	MOSFET(N-CHANNEL AP01L60J TO-251 APEC)	416-XP308I-352	1	

Power & Amp PCB Ass'y Part List

REF NO.	DESCRIPTION	PART NO.	Q'TY	REMARK
Q8	MOSFET(P-CHANNEL AP9435GJ TO-251 APEC)	416-XP308I-353	1	
PC1,PC2,PC3	IC(PC817C DIP-4)	417-TST4-806	3	
U2	Transition-mode PFC IC(L6562N DIP8 ST)	417-XP308I-929	1	
U4	LOW POWER SMPS IC(VIPER22A DIP8 ST)	417-XP308I-930	1	
F1	FUSE CLIPS(FS-001)	420-KT350A-004	2	
F1	FUSE(3.15A/250V 5*20 UL/CSA)	422-XM310-060	1	
	HEATSINK	425-STAGE-123	1	
	MICA SHEET(20*13*0.1mm)	501-TST4-2028	2	
	FUSE COVER	504-DJ2500J-046	1	
	SCREW(ISOB,3*14*P0.5,MC)	602-SA12-381	3	
	SCREW(TTB3*8)	602-XM610-528	4	
	CERAMIC TUBE (4*2*11.5mm)	605-KMD510P-034	1	
	WASHER	606-B300-039	3	
	WASHER(FIBER)	606-LC58FA-130	4	
	EVA	612-XP308I-322	1	
	EVA	612-XP308I-323	1	
	EVA CUSHION(32*15*1mm)	612-XPL200-293	2	
IC3	IC&HEADSINK ASS'Y	704-M2436FX-6837	1	
	IC(NJM7915FA)	417-RCC955A-291	1	
	HEAT SINK(AL)	425-KMD3500-016A	1	
	SCREW(TTB3*10)	602-XM610-522	1	
IC4	IC2&HEADSINK ASS'Y	704-M2436FX-6838	1	
	IC(NJM7815FA 3PIN)	417-DV330-216	1	
	HEAT SINK(AL)	425-KMD3500-016A	1	
	SCREW(TTB3*10)	602-XM610-522	1	
R96,R106,R174,R175,R176, R177,R86,R90	CHIP RESISTOR(5.6K OHM,1/8W, 0805,J,TP 150V)	412-CDMIX1-456	8	
R95,R58	CHIP RESISTOR(1K OHM,1/8W, 0805,J,TP 150V)	412-DV330-305	2	
R83,R84,R93,R92	CHIP RESISTOR(10K OHM,1/8W,0805,J,TP 150V)	412-DV330-306	4	
R87,R89	CHIP RESISTOR(100K OHM,1/8W, 0805,J,TP 150V)	412-DV330-307	2	
R130	CHIP RESISTOR(9.1K OHM,1/8W,J,TP 0805,150V)	412-M5-574	1	
C171,C129	CHIP CAPACITOR(220pF/50V,J,0805 TYPE,NPO)	413-AMC110D-5104	2	
C180	CHIP CAPACITOR(120pF/50V,J,0805 TYPE,NPO)	413-DFX1-746	1	
C179	CHIP CAPACITOR(0.1uF/ 50V,Z,0805 TYPE,Y5V)	413-DV330-313	1	
C101,C102,C143,C144	CHIP CAPACITOR(330pF/50V,J,0805 TYPE,NPO)	413-DV330-328	4	
C103,C104,C107,C108,C109, C110,C112,C113,C114,C115, C116,C183,C184,C185,C186, C145,C146,C149,C150,C151, C152,C153,C154,C155,C156, C128,C157,C158,C111,C170	CHIP CAPACITOR(0.1uF/100V,K,1206 X7R)	413-SZ480-1029	30	
IC100	IC(NJM-4580M-TE2,SOP-8)	417-ST150-599	1	
IC103,IC104	IC(TDA8920BTH)	417-SZ480-798	2	
IC105	IC(HEF4047BT)	417-SZ480-799	1	

Power & Amp PCB Ass'y Part List

REF NO.	DESCRIPTION	PART NO.	Q'TY	REMARK
C117,C118,C159,C160,C187,C189,C190,C191	CERAMIC CAPACITOR(220pF/50V,K,TAPING,Y5P)	413-3113-032	8	
C22,C33	ELEC. CAPACITOR(1uF/50V,M,105°C,TAPING 5*11)(Cd,Pb,Hg,Cr)	413-3113-049	2	
C16,C29,C34	ELEC. CAPACITOR(22uF/50V,M,105°C,TAPING 5*11)(Cd,Pb,Hg,Cr)	413-DM1000-351	3	
C12,C26	ELEC. CAPACITOR(47uF/50V,M,105°C,TAPING 6.3*11)(Cd,Pb,Hg,Cr)	413-DV300-5143	2	
C89,C90,C92,C93	MAYLAR CAP(0.15uF/100V J TAPING)	413-HPA5000-948	4	
C99,C100,C141,C142	ELEC. CAPACITOR (47uF/25V M 105°C, TAPING 5*11)(Cd,Pb,Hg,Cr)	413-HS100-181	4	
C135,C177,C176,C134	ELEC. CAPACITOR(220uF/35V,M, 105°C,TAPING 8*14)	413-HT7016-270	4	
C15,C27	CERAMIC ELECTRIC CAPACITY(2200PF 1KV Y5P TAPING)	413-IS303-1075	2	
C45,C55	ELEC. CAPACITOR(220uF/10V,M,105°C,TAPING 6.3*11)(Cd,Pb,Hg,Cr)	413-KC220-119	2	
C14,C28	POLYESTER CAPACITOR(0.1uF/100V,J,TAPING)	413-KT350-089	2	
C31,C32	ELEC.CAPACITOR(100uF/16V,M,105°C,TAPING 5*11)	413-PXE90-109	2	
C120,C119,C161	METAL POLYESTER CAPACITOR(0.68uF/100V J TAPING)	413-SZ480-1031A	3	
C121,C122,C164,C163	METAL POLYESTER CAPACITOR(0.1uF/63V J TAPING, SMALL TYPE)	413-SZ480-1032	4	
C9	CAPACITOR(0.22uF 50V M Y5V TAPING)	413-XP308I-1131	1	
C8,C10	CAPACITOR(1000pF 50V K Y5V TAPING)	413-XP308I-1134	2	
C13	CAPACITOR(0.47uF 50V M Y5V TAPING)	413-XP308I-1137	1	
U6,U5	Transistor(H431BA TO-92 HI-SINCERITY)	416-XP308I-349	2	
Q5	Transistor(NPN KRC105M TO-92M KEC)	416-XP308I-354	1	
Q2	Transistor(PNP KRA102M TO-92M KEC)	416-XP308I-355	1	
	POWER& PCB(FR-4 T:1.6mm 247*140)	405-XP308I-2397	1	
R82	CARBON FILM RESISTOR(5.6K OHM,1/6W,J,T-26)	412-3113-044	1	
R24	CARBON FILM RESISTOR(270 OHM,1/6W,J,T-26)	412-3113-049	1	
R30	CARBON FILM RESISTOR(4.7K OHM,1/6W,J,T-26)	412-3113-055	1	
R23	CARBON FILM RESISTOR(470 OHM,1/6W,J,T-26)	412-3113-056	1	
R14,R7,R60	CARBON FILM RESISTOR(100 OHM,1/6W,J,T-26)	412-3113-060	3	
R5	CARBON FILM RESISTOR((47K OHM,1/6W,J,T-26)	412-3113-063	1	
R38,R44	CARBON FILM RESISTOR((2.7K OHM,1/6W,J,T-26)	412-3113-073	2	
R41,R37	CARBON FILM RESISTOR(390 OHM,1/6W,J,T-26)	412-3113-076	2	
R25,R31	CARBON FILM RESISTOR(1K OHM,1/6W,J,T-26)	412-3113-078	2	
R42,R34,R35	CARBON FILM RESISTOR(0 OHM J 1/6W TAPING 26mm)	412-3113-929	3	
R4,R9,R13,R43	METAL FILM RESISTOR(10K,1/6W,F,T-26)	412-DFX1-653	4	
R8	CARBON FILM RESISTOR(10 OHM,1/6W,J,T-26)	412-KC220-132	1	
R28	CARBON FILM RESISTOR(330 OHM,1/6W,J,T-26)	412-KM300-118	1	
R33	CARBON FILM RESISTOR(4.7 OHM,1/4W,J,T-52)	412-KM501-293	1	
R6	CARBON FILM RESISTOR(510K OHM,1/6W,J,T-26)	412-KMD3500-366	1	
R39	RESISTER(3K F 1/6W T-26mm)	412-Q2131-1081	1	
R26	CARBON FILM RESISTOR(20K OHM 1/6W,J TAPING 26mm)	412-XM910-868	1	
R11	Resistor(820KΩ 1/6W F T-26)	412-XP308I-1355	1	
R12	Resistor(750KΩ,1/6W,F,T-26)	412-XP308I-1356	1	
R27	Resistor(1.8KΩ,1/6W,F,T-26)	412-XP308I-1359	1	
R40	Precision Resistor(2.75K,1/6W,F,T-26)	412-XP308I-1397	1	
D24,D4,D16,D18	SWITCHING DIODE(1N4148,1/2W,150mA/100V,T-77)	414-2002-002	4	
D101	ZENER DIODE(MTZJ5.6-C,1/2W,T-77)	414-DCM270X-089	1	
ZD1	ZENER DIODE(1N5254B,1/2W,T=26mm,CAMBRIDGE)	414-XP308I-281	1	

1	2	3	4	5	6	7	8	9	
COMPANY	SAMSON	APPLICANT	MP	REVISED NUMBER AND DATE	S	DRAWN	CHECKED	APPROVED	NOTE
TYPE CODE				1. Update 2008.4.3	4.	7.			
APPROVED DATE	2008.12.18			2. Update 2008.4.7	5.	8.			
				3. Update 2008.5.8	6.	9.			
					G	N	HeJian	Ku	J.K

First MP

SHEET NO. SCHEMATIC DIAGRAM
MODEL : XP308i Mixer 1/2

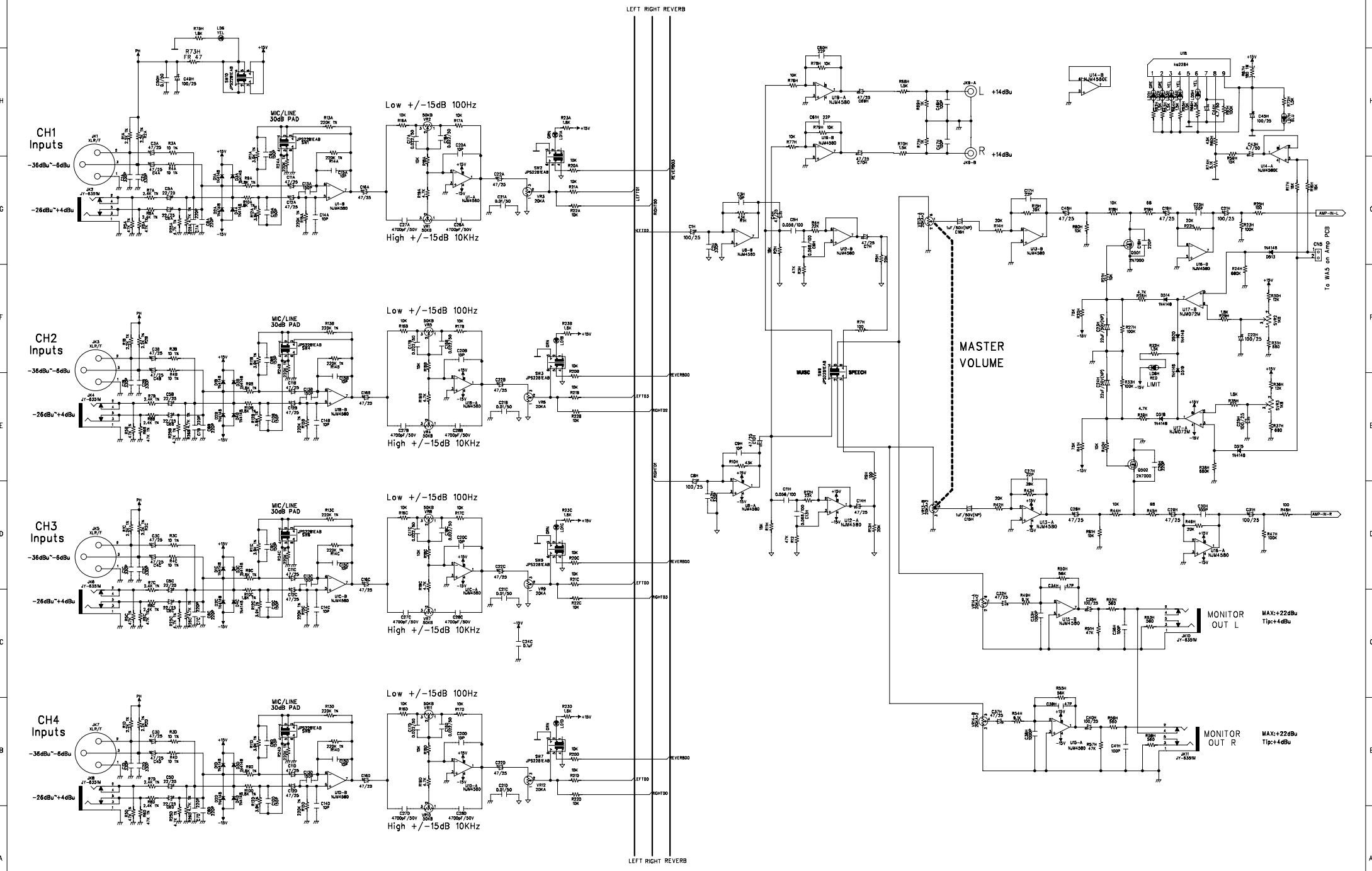

20

A

A

1	2	3	4	5	6	7	8	9
COMPANY	SAMSON	APPLICANT	REVISED NUMBER AND DATE	DRAWN	CHECKED	APPROVED	NOTE	
TYPE CODE		MP	1. Update 2008.4.3 2. Update 2008.4.7 3. Update 2008.5.8	G HeJian	Ku	J.K		
APPROVED DATE	2008.12.18		4. Update 2009.5.19 5. 6. 7. 8. 9.					

First MP

SHEET NO.	SCHEMATIC DIAGRAM
	MODEL : XP308i Mixer 2/2 & l'pod

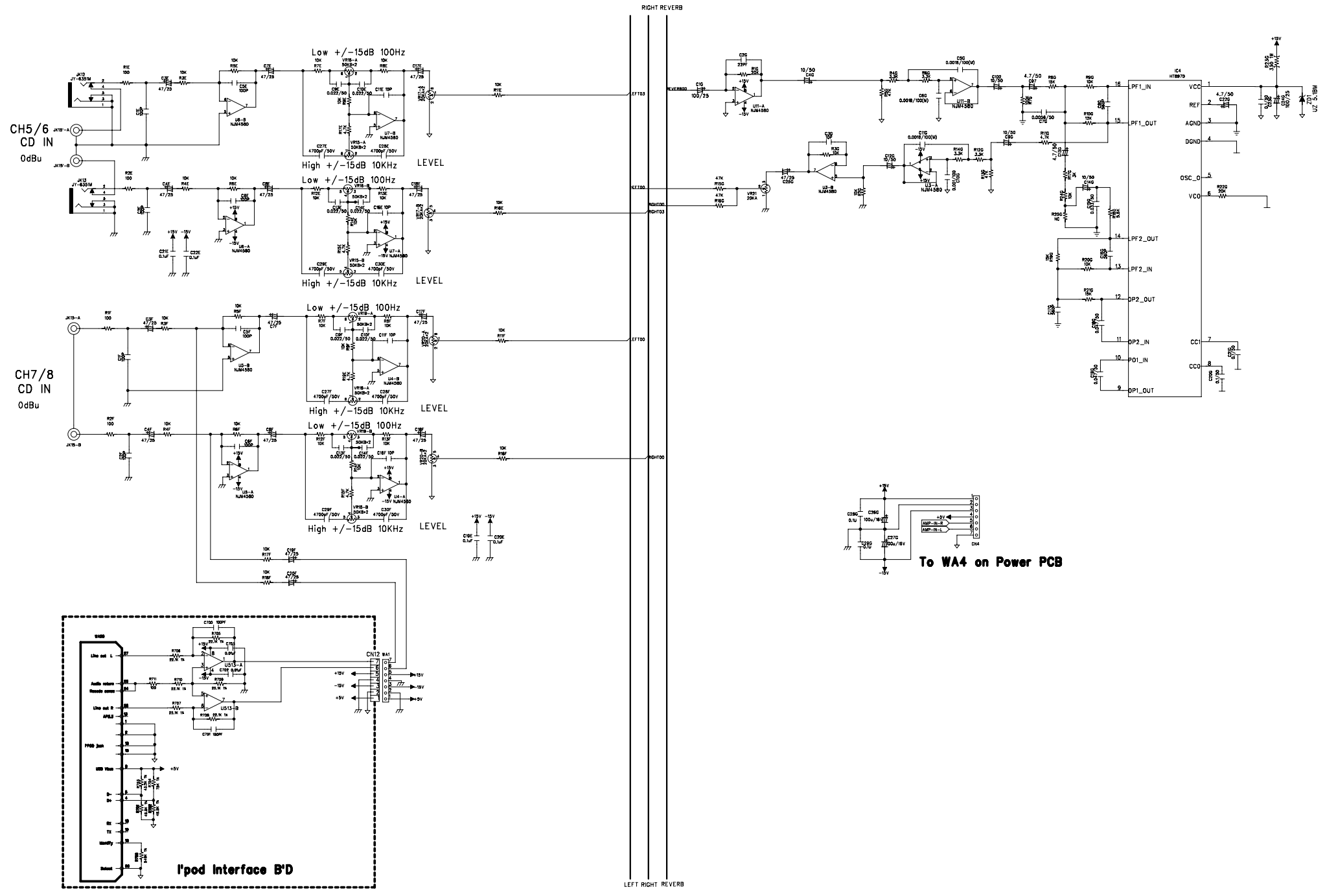

To WA4 on Power PCB

l'pod interface B'D

LEFT RIGHT REVERB

1		2		3		4		5		6	
COMPANY	SAMSON	APPLICANT	MP	REVISED NUMBER AND DATE	1. Update 2009.4.3 2. Update 2009.5.15 3.	4. 5. 6.	7. 8. 9.	DESIGN	HeJian	Checked	Ku
TYPE CODE								APPROVED	J.K	NOTE	
APPROVED DATE	2008.12.18							First MP		SCHEMATIC DIAGRAM	
								SHEET NO.		MODEL : XP308i Amp&Power 2/2	

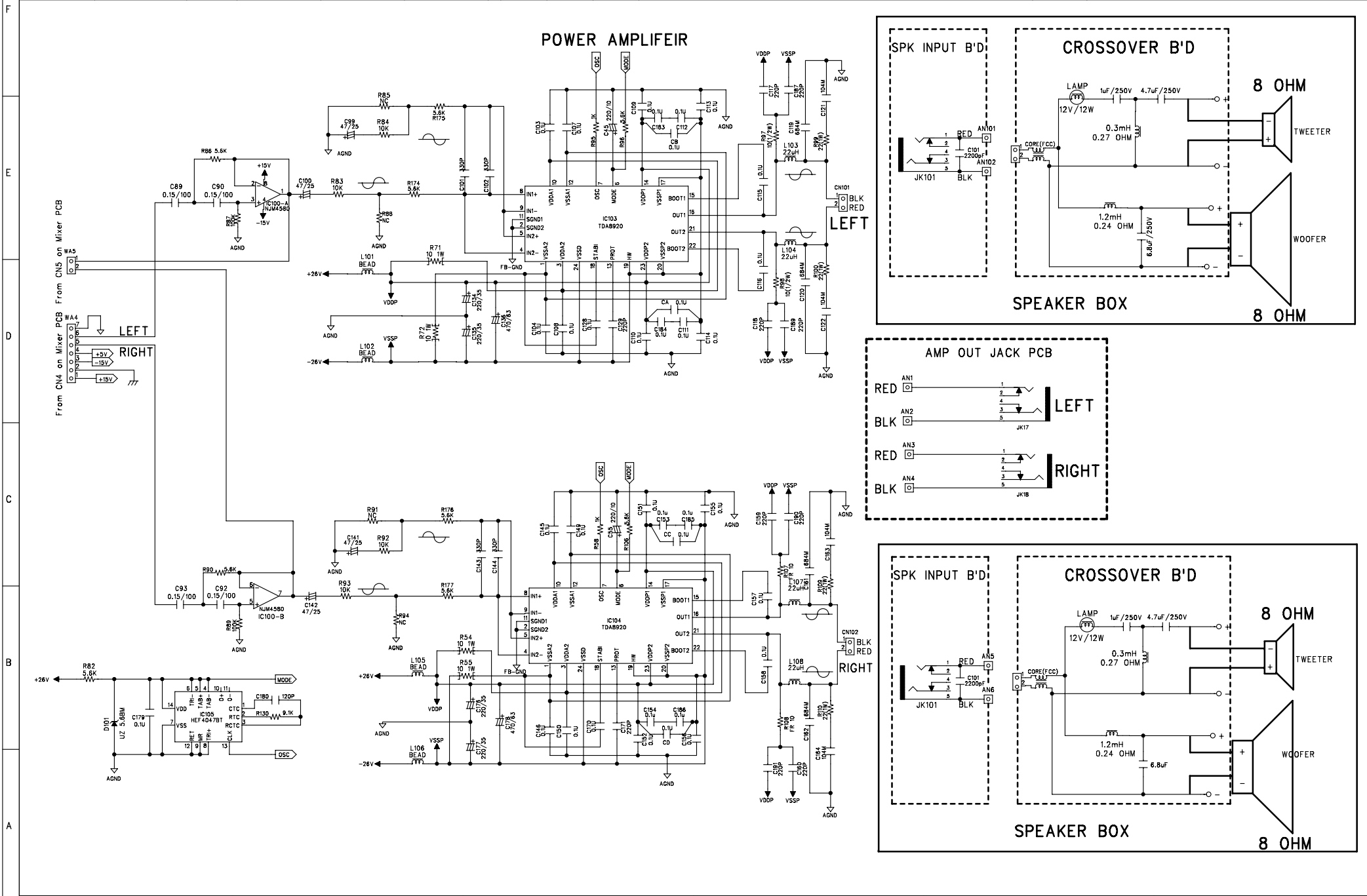

417-ACE-781 IC(TL072C/CD OA2 JFET SO8 SGS)

Figure 1. Standard Compensation and Offset Balancing Circuit

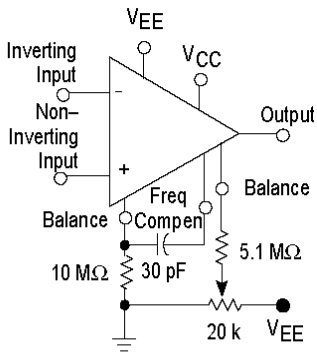

Figure 2. Double-Ended Limit Detector

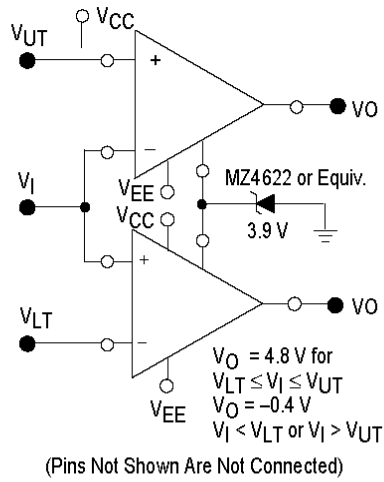
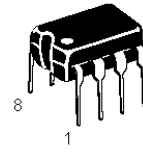
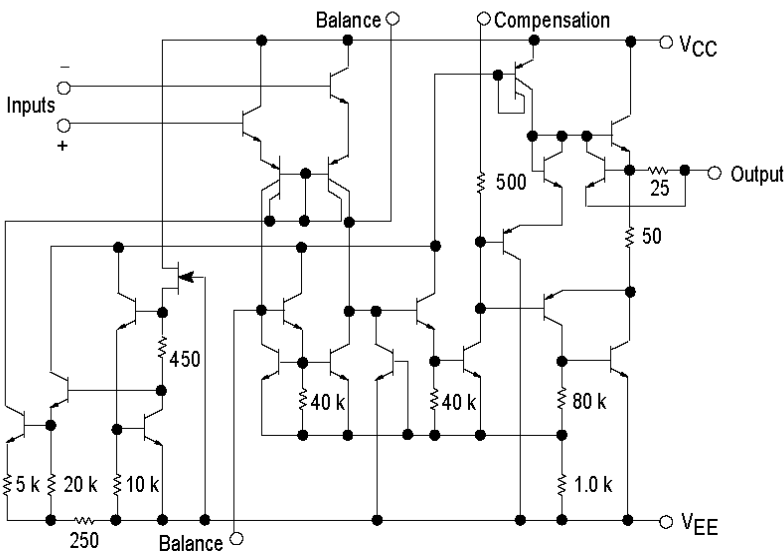

Figure 3. Representative Circuit Schematic



**N SUFFIX
PLASTIC PACKAGE
CASE 626**



**D SUFFIX
PLASTIC PACKAGE
CASE 751
(SO-8)**

PIN CONNECTIONS

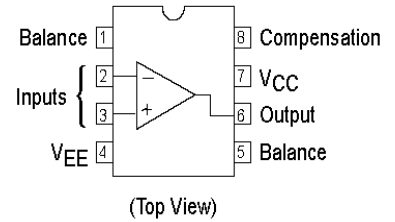

417-XM910-779 IC(KA2284B)

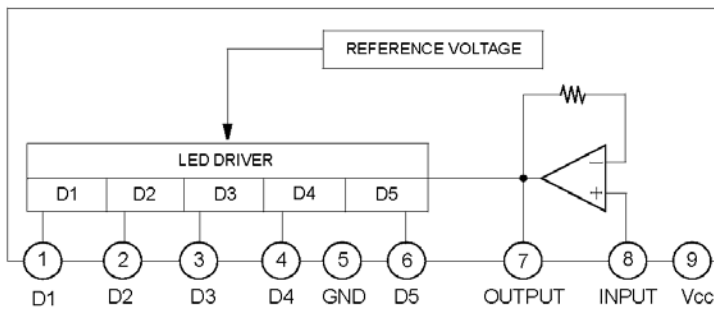

9-SIP

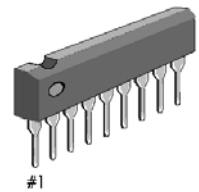

IC Block Diagram

417-TST4-806 IC(PC817C DIP-4)

■ Outline Dimensions

(Unit : mm)

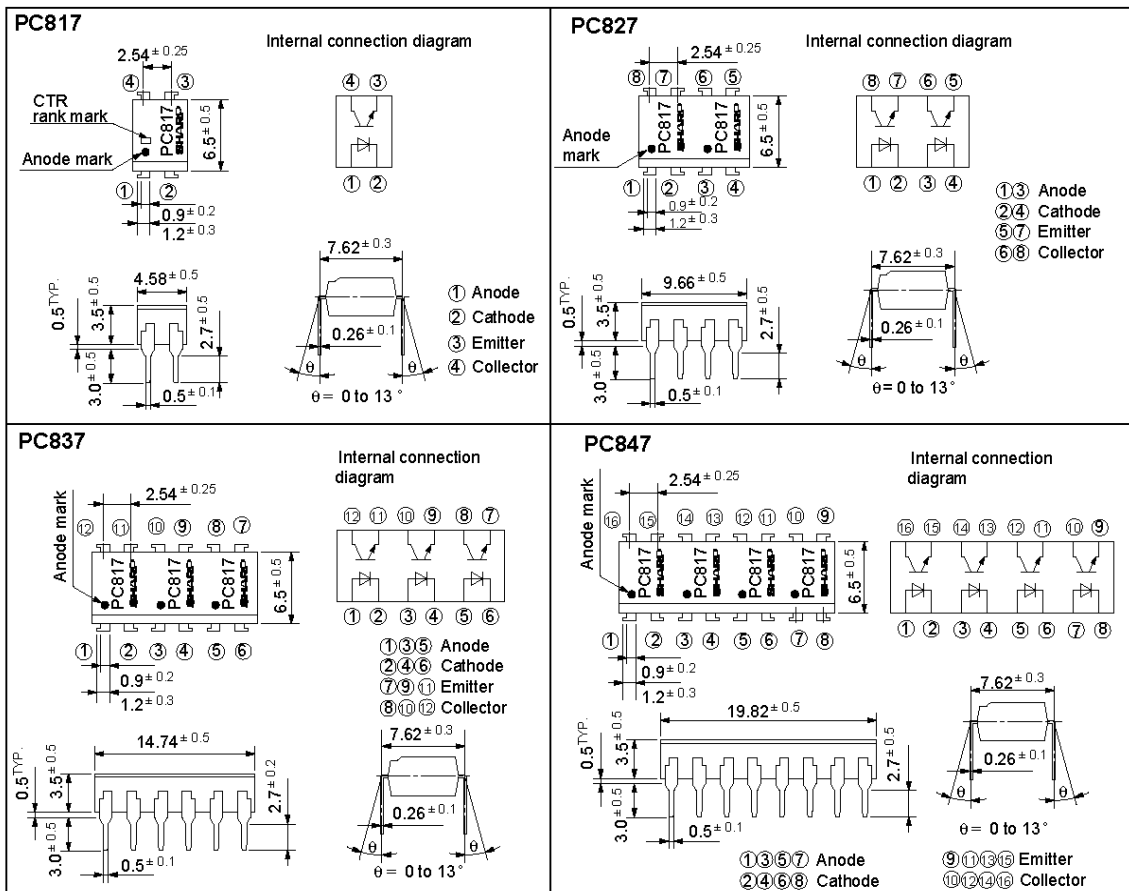

417-XP308I-927 Voice Echo IC(HT8970 SOP-16 HOLTEK)

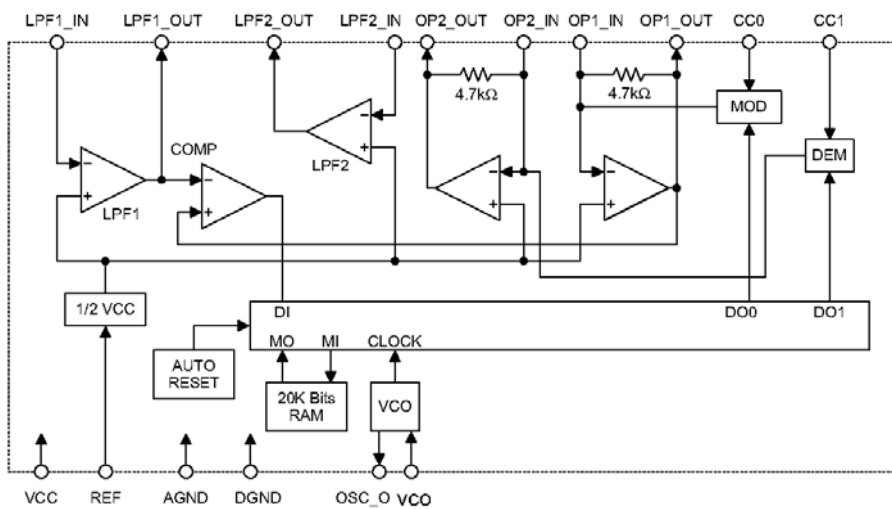

Pin Assignment

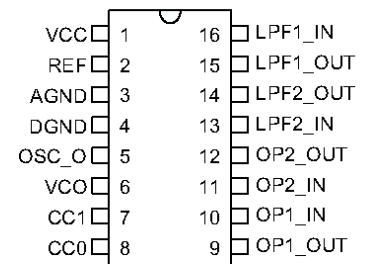

HT8970
- 16 DIP/SOP

IC Block Diagram

417-XP308I-928 SMPS IC(KA1M0880B TO-3P-5L FAIRCHILD)

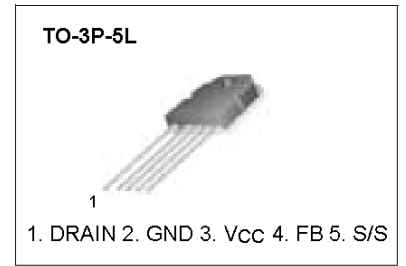
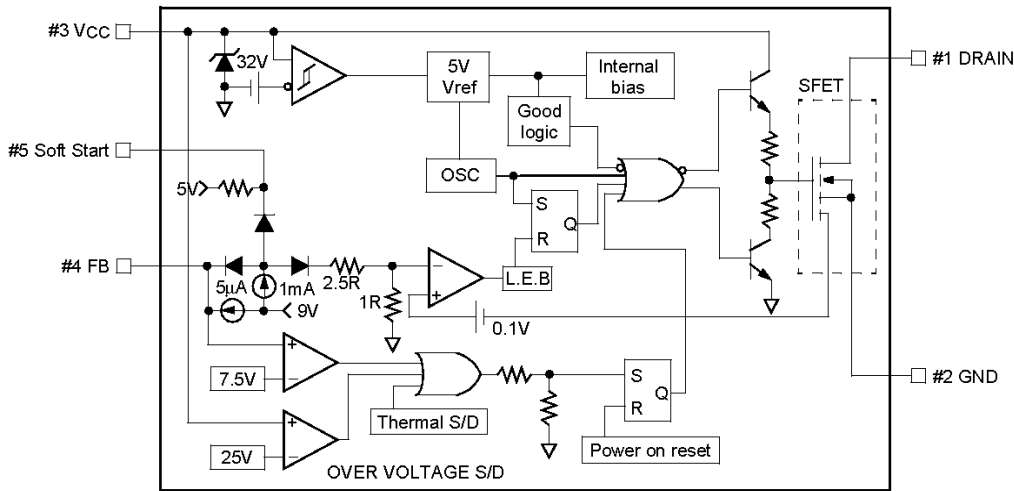

417-XP308I-929 Transition-mode PFC IC(L6562N DIP8 ST)

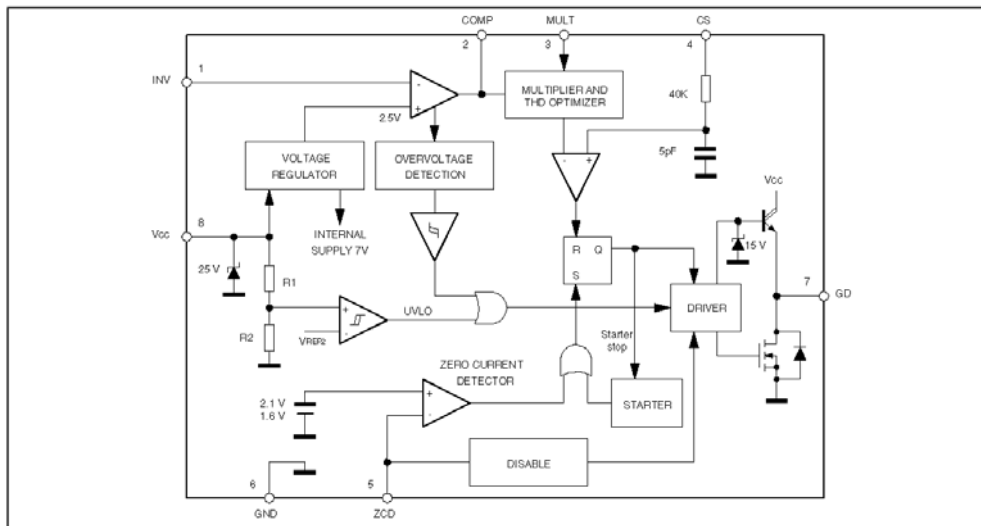

417-XP308I-930 LOW POWER SMPS IC(VIPER22A DIP8 ST)

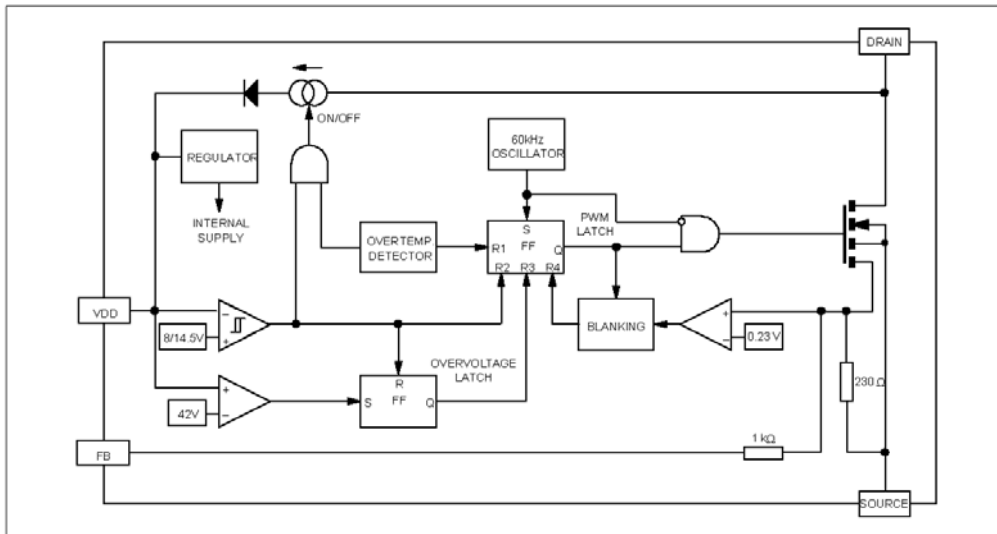

ORDER CODES		
PACKAGE	TUBE	T&R
SO-8	VIPer22AS	VIPer22AS13TR
DIP-8	VIPer22ADIP	-

417-SZ480-798
IC(TDA8920BTH)

Block diagram

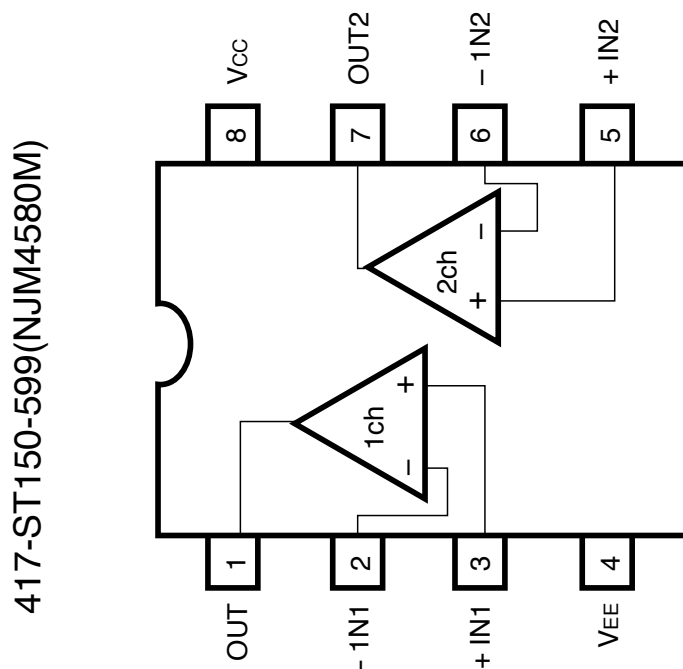
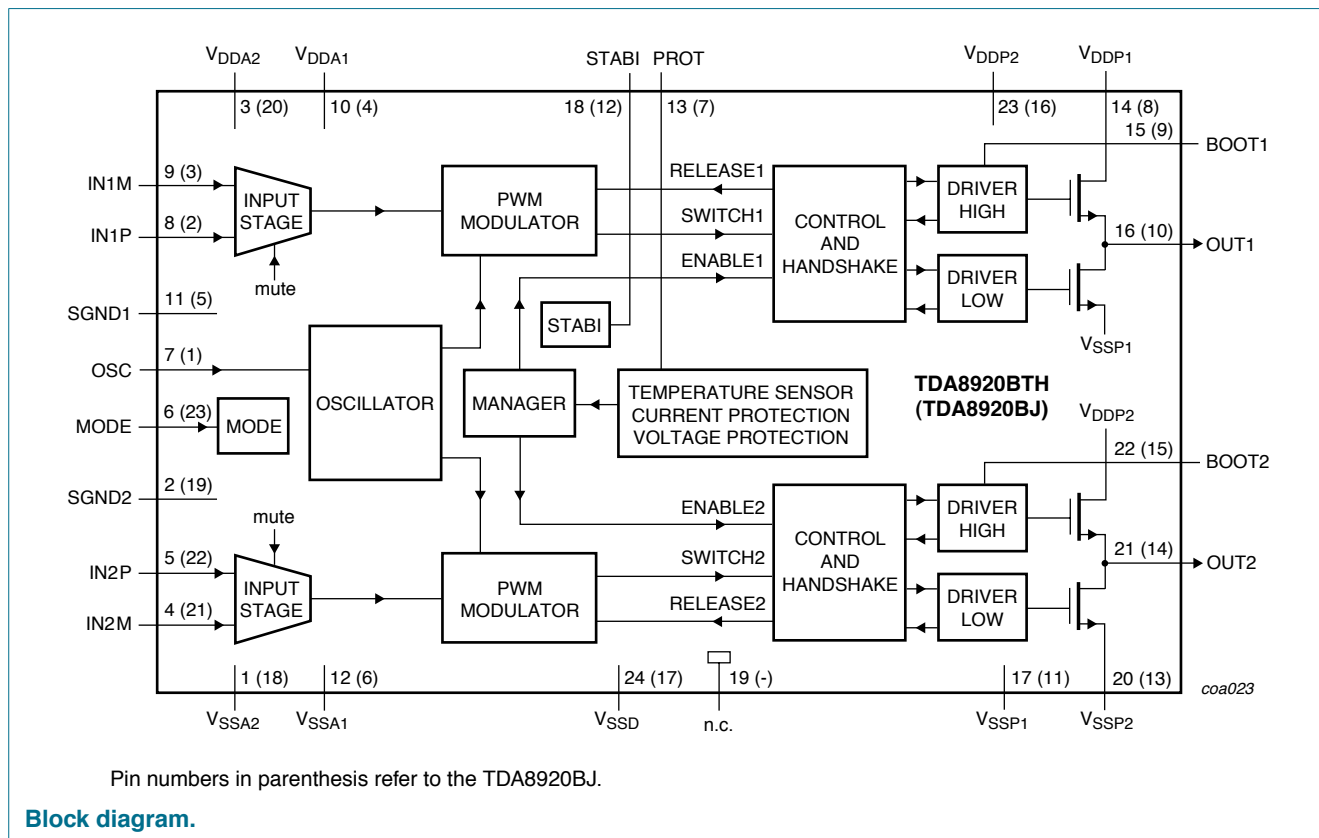

HEF4047B

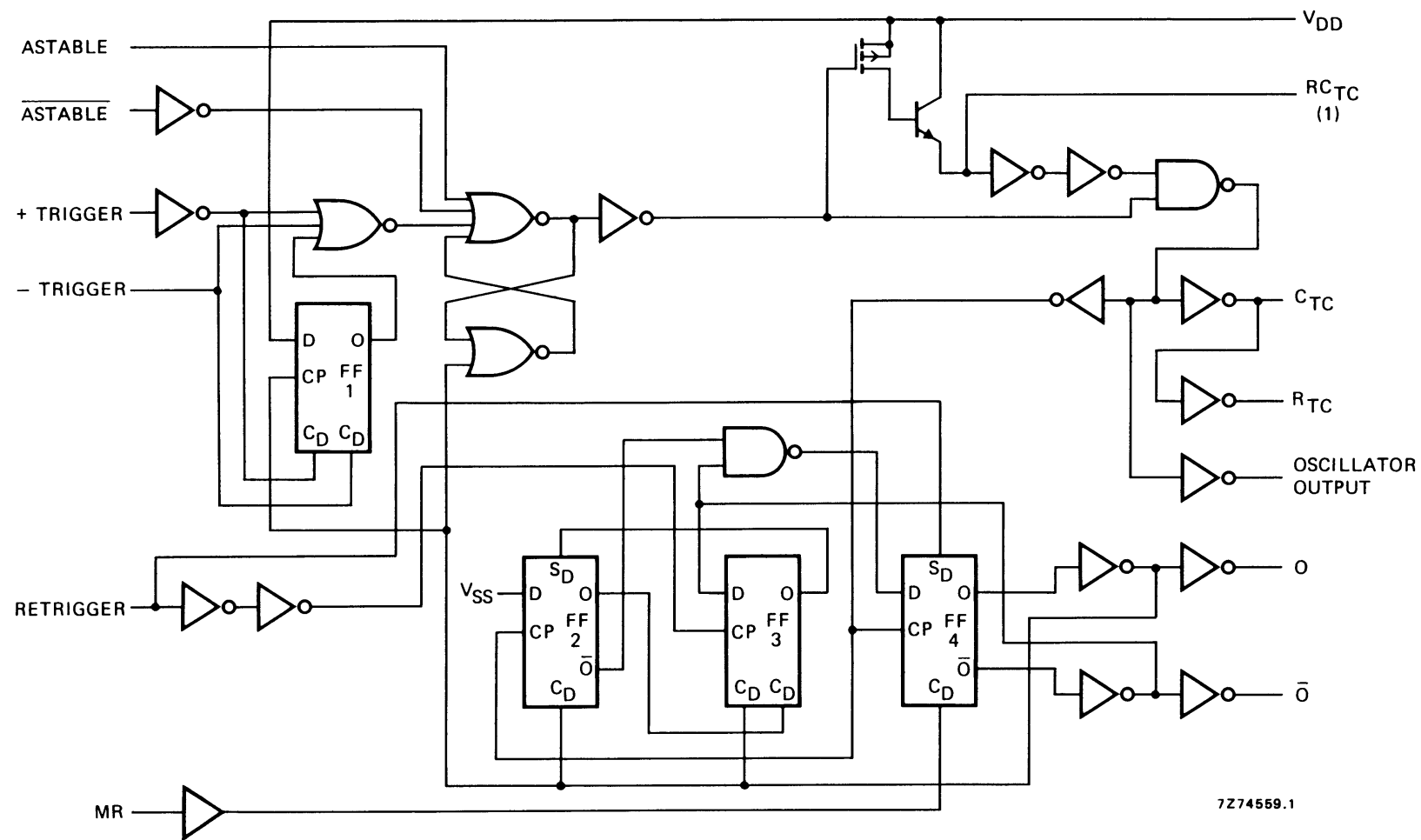

(1) Special input protection that allows operating input voltages outside the supply voltage lines. Compared to the standard input protection pin 3 is more sensitive to static discharge; extra handling precautions are recommended.

Logic diagram.

