

**INDOOR UNIT**
**SERVICE MANUAL**
**No. OB450**
**Wireless type  
Models**

**MSZ-A09NA**  
**MSZ-A12NA**  
**MSZ-A15NA**  
**MSZ-A17NA**  
**MSZ-A24NA**  
**MSY-A15NA**  
**MSY-A17NA**  
**MSY-A24NA**

Outdoor unit service manual  
 MUZ-A-NA Series (OB451)  
 MXZ-A-NA Series (OB444)

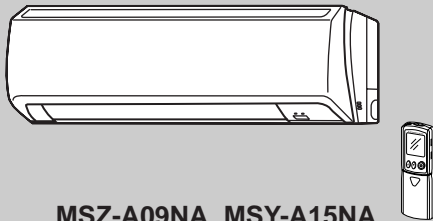

MSZ-A09NA MSY-A15NA  
 MSZ-A12NA MSY-A17NA  
 MSZ-A15NA  
 MSZ-A17NA

**CONTENTS**

1. TECHNICAL CHANGES .....	2
2. PART NAMES AND FUNCTIONS.....	3
3. SPECIFICATION.....	4
4. OUTLINES AND DIMENSIONS .....	6
5. WIRING DIAGRAM .....	8
6. REFRIGERANT SYSTEM DIAGRAM .....	9
7. SERVICE FUNCTIONS .....	10
8. TROUBLESHOOTING.....	11
9. DISASSEMBLY INSTRUCTIONS .....	25
10. PARTS LIST.....	30
10-1. PARTS LIST.....	30
10-2. RoHS PARTS LIST.....	36
11. MICROPROCESSOR CONTROL.....	42

**NOTE:**

This service manual describes technical data of the indoor units.  
 RoHS compliant products have <G> mark on the spec name plate.  
 For servicing of RoHS compliant products, refer to the PARTS  
 LIST (RoHS compliant).



**MSZ09UN → MSZ-A09NA**  
**MSZ12UN → MSZ-A12NA**  
**MSH15TN → MSZ-A15NA**  
**MSH17TN → MSZ-A17NA**  
**MSH24WN → MSZ-A24NA**  
**MS15TN → MSY-A15NA**  
**MS17TN → MSY-A17NA**  
**MS24WN → MSY-A24NA**

- 1.Control method between indoor and outdoor has been changed.
- 2.Indoor fan motor has been changed.
- 3.Signal of remote controller has been changed. (It is not available for conventional models.)

# 2

# PART NAMES AND FUNCTIONS

MSZ-A09NA  
MSZ-A12NA  
MSZ-A15NA  
MSZ-A17NA

MSY-A15NA  
MSY-A17NA

MSZ-A24NA  
MSY-A24NA

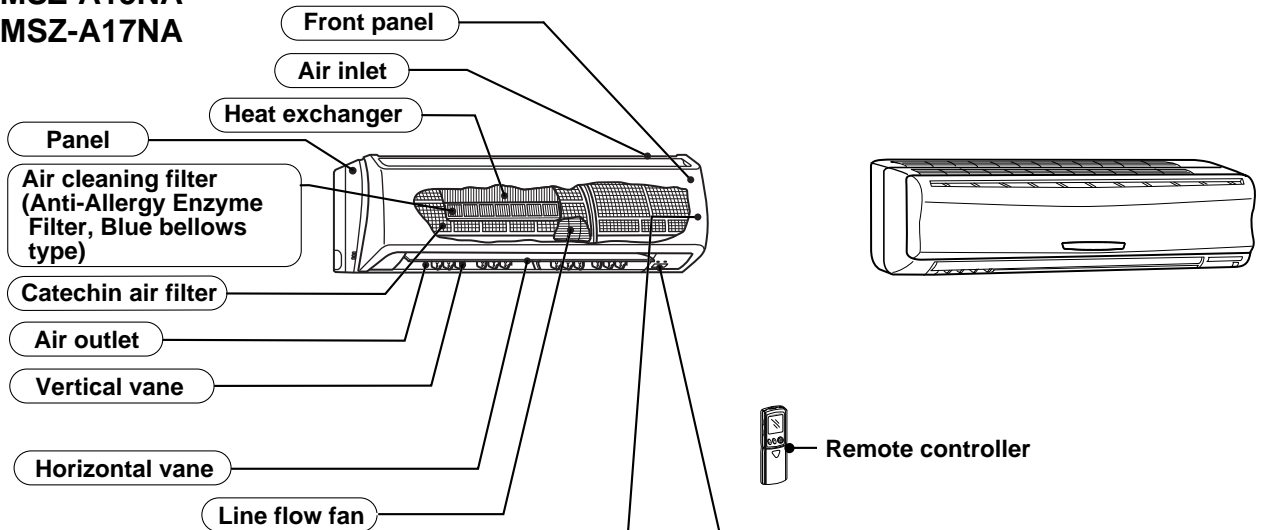

MSZ-A09NA  
MSZ-A12NA  
MSZ-A15NA  
MSZ-A17NA  
MSY-A15NA  
MSY-A17NA

Operation section (When the front panel is opened)      Display section

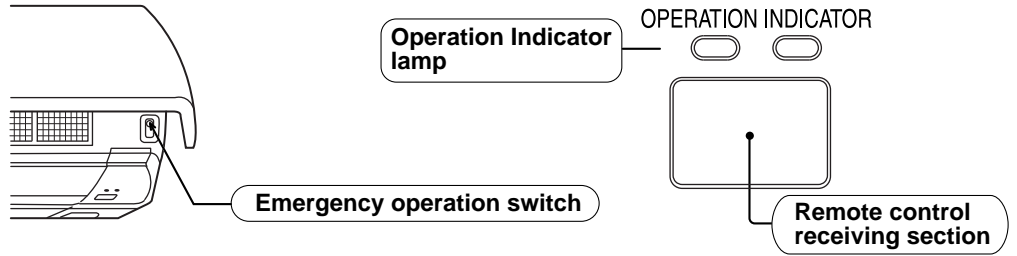

MSZ-A24NA  
MSY-A24NA

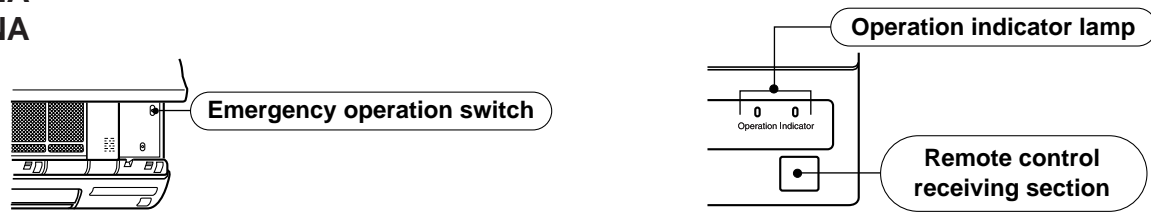

## ACCESSORIES

		MSZ-A09NA MSZ-A12NA MSZ-A15NA	MSZ-A17NA MSY-A15NA MSY-A17NA	MSZ-A24NA MSY-A24NA
①	Installation plate		1	1
②	Installation plate fixing screw 4 × 25 mm		8	7
③	Remote controller holder		1	1
④	Fixing screw for ③ × 3.5 × 1.6 mm (Black)		2	2
⑤	Battery (AAA) for remote controller		2	2
⑥	Wireless remote controller		1	1
⑦	Felt tape (Used for left or left-rear piping)		1	1
⑧	Conduit plate		1	—

# 3

# SPECIFICATION

Item	Model	MSZ-A09NA	MSZ-A12NA
INDOOR UNIT MODEL		MSZ-A09NA	MSZ-A12NA
External finish		White	
Power supply	V, phase, Hz	208/230, 1, 60	
Max.-fuse size (time delay)/ Disconnect switch	A	15	
Min. circuit ampacity	A	1.0	1.0
Fan motor	F.L.A	0.76	0.76
Airflow Low—Med.—High	HEAT Dry	CFM	307-222-159
	COOL Dry (Wet)	CFM	353(318)-240(215)-152(134)
Moisture removal	pt./h	2.3	3.2
Sound level Low-Med.-High	dB(A)	22-33-38	22-34-42
Cond. drain connection O.D.	in.	5/8	
Dimensions	W	30-11/16	
	D	8-1/4	
	H	11-3/4	
Weight	lb.	23	23
REMOTE CONTROLLER		Wireless type	
Control voltage (by built-in transformer)		12-24V DC	

Item	Model	MSZ-A15NA	MSY-A15NA	MSZ-A17NA	MSY-A17NA
INDOOR UNIT MODEL		MSZ-A15NA	MSY-A15NA	MSZ-A17NA	MSY-A17NA
External finish		White			
Power supply	V, phase, Hz	208/230, 1, 60			
Max.-fuse size (time delay)/ Disconnect switch	A	15			
Min. circuit ampacity	A	1.0		1.0	
Fan motor	F.L.A	0.76		0.76	
Airflow Low—Med.—High	HEAT Dry	CFM	381-314-254	381-314-254	—
	COOL Dry (Wet)	CFM	381(342)-328(293)-268(240)	381(342)-328(293)-268(240)	—
Moisture removal	pt./h	4.7		5.1	
Sound level Low-Med.-High (Cooling/Heating)	dB(A)	34-40-45/34-38-44	34-40-45/ —	34-40-46/34-38-44	34-40-46/ —
Cond. drain connection O.D.	in.	5/8			
Dimensions	W	30-11/16			
	D	8-1/4			
	H	11-3/4			
Weight	lb.	23		23	
REMOTE CONTROLLER		Wireless type			
Control voltage (by built-in transformer)		12-24V DC			

Item	Model	MSZ-A24NA	MSY-A24NA
INDOOR UNIT MODEL		MSZ-A24NA	MSY-A24NA
External finish		White	
Power supply	V, phase, Hz	208/230, 1, 60	
Max.-fuse size (time delay)/ Disconnect switch	A	15	
Min. circuit ampacity	A	1.0	1.0
Fan motor	F.L.A	0.76	0.76
Airflow Low—Med.—High	HEAT Dry	CFM	568-486-296
	COOL Dry (Wet)	CFM	568(508)-431(385)-296(265)
Moisture removal	pt./h	7.3	7.3
Sound level Low-Med.-High (Cooling/Heating)	dB(A)	34-40-49/34-40-48	34-40-49/ —
Cond. drain connection O.D.	in.	5/8	
Dimensions	W	43-5/16	
	D	10-1/4	
	H	12-13/16	
Weight	lb.	37	37
REMOTE CONTROLLER		Wireless type	
Control voltage (by built-in transformer)		12-24V DC	

NOTE : Test conditions are based on ARI 210/240.

\*1 : Rating conditions (cooling) — Indoor : 80°FDB, 67°F WB, Outdoor : 95°FDB, (75°F WB)  
 (heating) — Indoor : 70°FDB, 60°F WB, Outdoor : 47°FDB, 43°F WB

\*2 : (heating) — Indoor : 70°FDB, 60°F WB, Outdoor : 17°FDB, 15°F WB

### 3-1. OPERATING RANGE

#### (1) POWER SUPPLY

Model	Rated voltage	Guaranteed Voltage
MSZ-A09NA MSY-A15NA MSZ-A12NA MSY-A17NA MSZ-A15NA MSY-A24NA MSZ-A17NA MSZ-A24NA	208/230V 1phase 60Hz	Min. 198V 208V 230V Max. 253V ----- ----- ----- -----

#### (2) OPERATION

Function	Intake air temperature Condition	Indoor		Outdoor	
		DB (°F)	WB (°F)	DB (°F)	WB (°F)
Cooling	Standard temperature	80	67	95	—
	Maximum temperature	95	71	115	—
	Minimum temperature	67	57	14	—
	Maximum humidity	78%		—	
Heating	Standard temperature	70	60	47	43
	Maximum temperature	80	67	75	65
	Minimum temperature	70	60	14	13

### 3-2. OUTLET AIR SPEED AND COVERAGE RANGE

Model	Mode	Function	Air flow (CFM)	Air speed (ft./sec.)	Coverage range (ft.)
MSZ-A09NA	HEAT	Dry	307	16.8	23.4
	COOL	Dry	307	16.8	23.4
		Wet	275	15.1	21.0
MSZ-A12NA	HEAT	Dry	353	19.3	26.7
	COOL	Dry	353	19.3	26.7
		Wet	318	17.4	24.1
MSZ-A15NA	HEAT	Dry	381	20.9	28.8
MSZ-A15NA MSY-A15NA	COOL	Dry	381	20.9	28.8
		Wet	342	18.8	26.0
MSZ-A17NA	HEAT	Dry	381	20.9	28.8
MSZ-A17NA MSY-A17NA	COOL	Dry	381	20.9	28.8
		Wet	342	18.8	26.0
MSZ-A24NA	HEAT	Dry	568	20.2	34.4
MSZ-A24NA MSY-A24NA	COOL	Dry	568	20.2	34.4
		Wet	508	18.1	30.9

- The air coverage range is the figure up to the position where the air speed is 1 ft./sec., when air is blown out horizontally from the unit properly at the High speed position. The coverage range should be used only as a general guideline since it varies according to the size of the room and furniture arranged inside the room.

# 4

# OUTLINES AND DIMENSIONS

MSZ-A09NA MSY-A15NA  
 MSZ-A12NA MSY-A17NA  
 MSZ-A15NA  
 MSZ-A17NA

Unit : inch

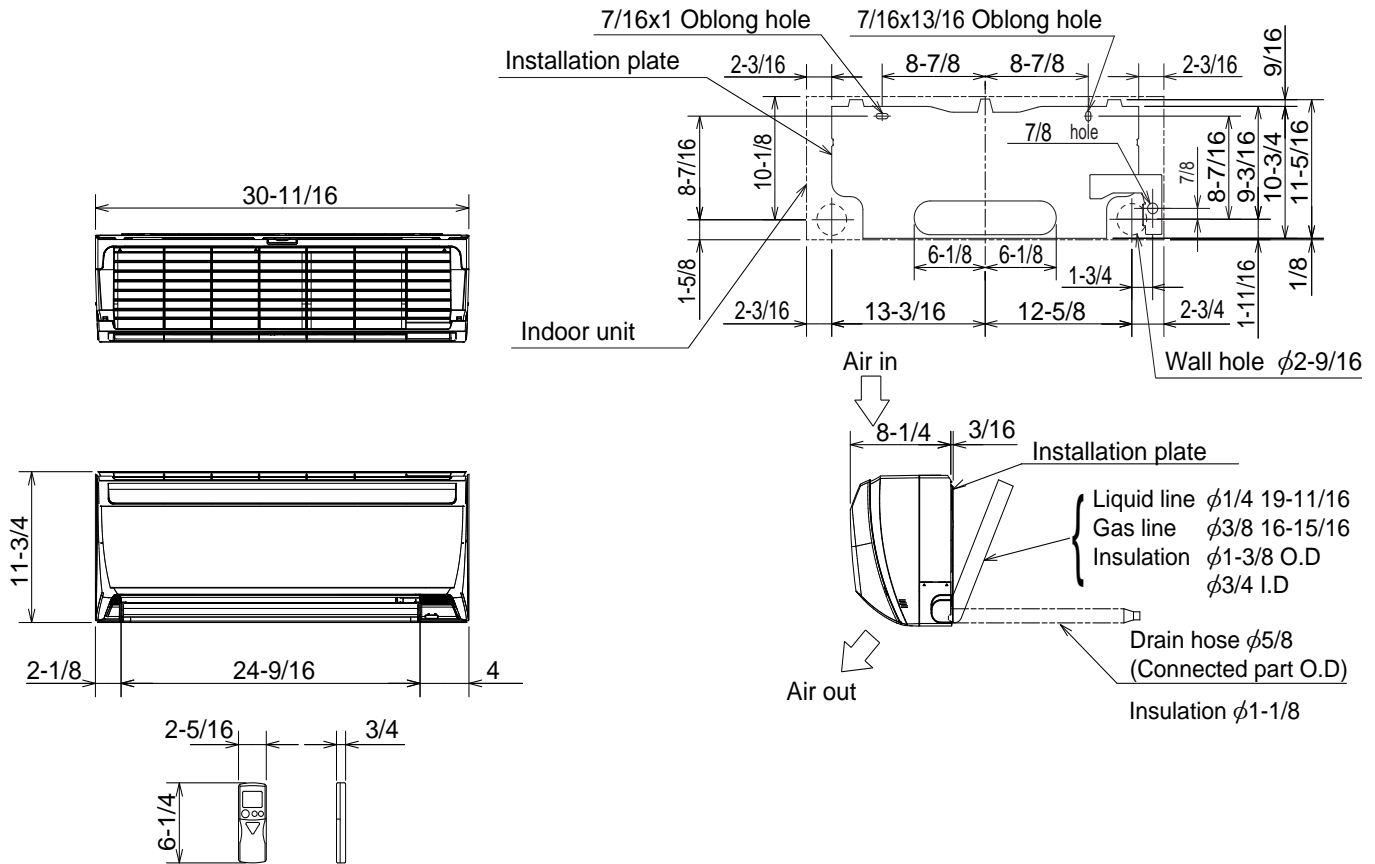

**MSZ-A24NA**  
**MSY-A24NA**

Unit : inch

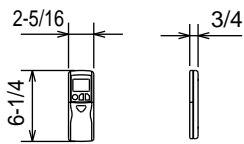
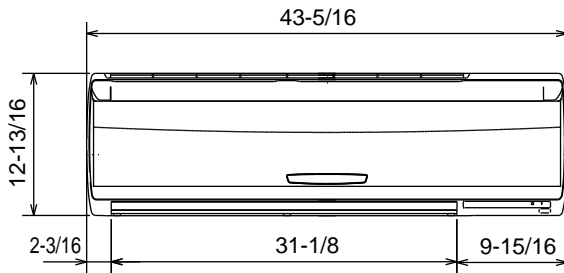
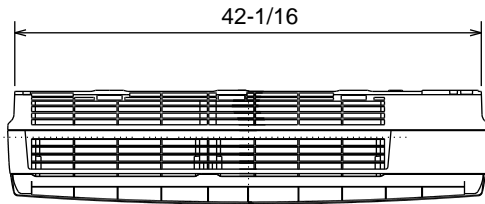

Wireless remote controller

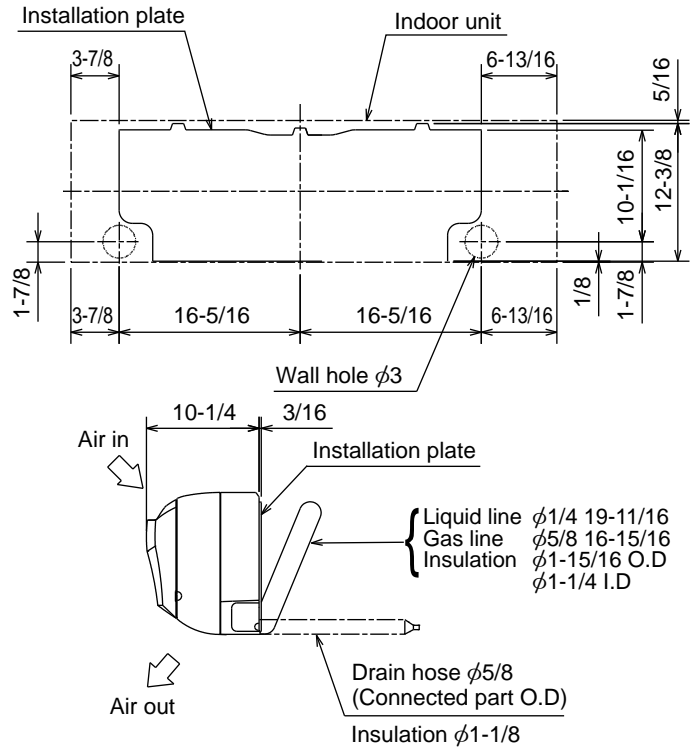

# 5

# WIRING DIAGRAM

MSZ-A09NA MSY-A15NA  
 MSZ-A12NA MSY-A17NA  
 MSZ-A15NA  
 MSZ-A17NA

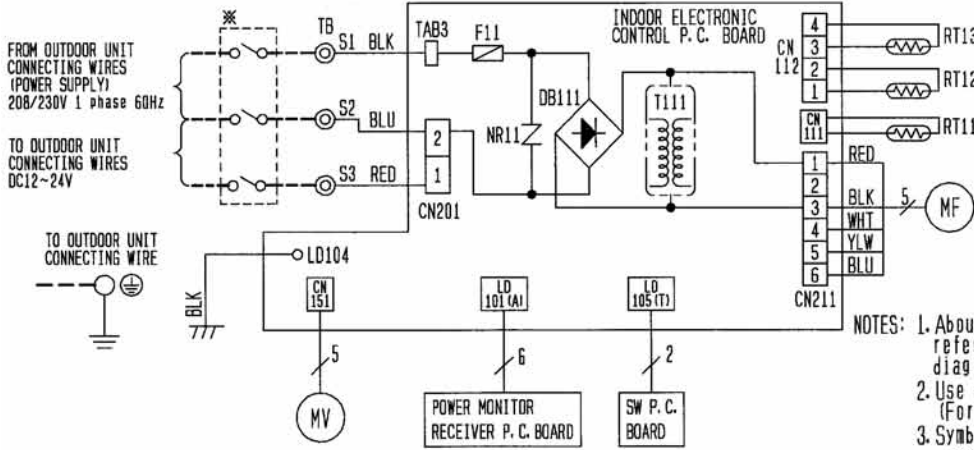

SYMBOL	NAME	SYMBOL	NAME
DB111	DIODE STACK	RT11	ROOM TEMP. THERMISTOR
F11	FUSE (T3.15A/250V)	RT12	COIL TEMP. THERMISTOR (MAIN)
MF	FAN MOTOR	RT13	COIL TEMP. THERMISTOR (SUB)
MV	VANE MOTOR (HORIZONTAL)	T111	SWITCHING TRANSFORMER
NR11	VARISTOR	TB	TERMINAL BLOCK

- NOTES: 1. About the outdoor side electric wiring refer to the outdoor unit electric wiring diagram for servicing.  
 2. Use copper conductors only. (For field wiring)  
 3. Symbols below indicate.  
 ⊙ : Terminal block  
 □ : Connector

\* A disconnect may be required by local code.

MSZ-A24NA  
 MSY-A24NA

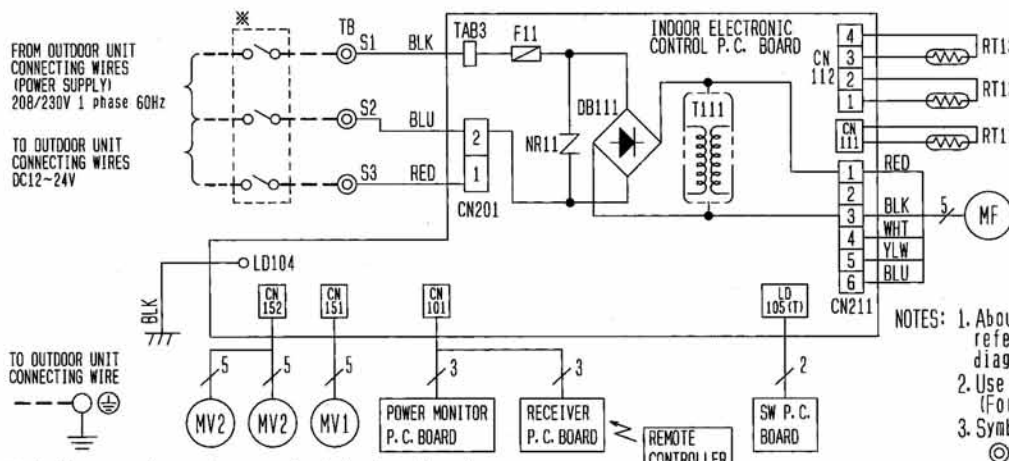

SYMBOL	NAME	SYMBOL	NAME
DB111	DIODE STACK	RT11	ROOM TEMP. THERMISTOR
F11	FUSE (3.15A)	RT12	COIL TEMP. THERMISTOR (MAIN)
MF	FAN MOTOR	RT13	COIL TEMP. THERMISTOR (SUB)
MV1	VANE MOTOR (HORIZONTAL)	T111	TRANSFORMER
MV2	VANE MOTOR (VERTICAL)	TB	TERMINAL BLOCK
NR11	VARISTOR		

- NOTES: 1. About the outdoor side electric wiring refer to the outdoor unit electric wiring diagram for servicing.  
 2. Use copper conductors only. (For field wiring)  
 3. Symbols below indicate.  
 ⊙ : Terminal block  
 □ : Connector

\* A disconnect may be required by local code.

# 6

# REFRIGERANT SYSTEM DIAGRAM

**MSZ-A09NA**  
**MSZ-A12NA**

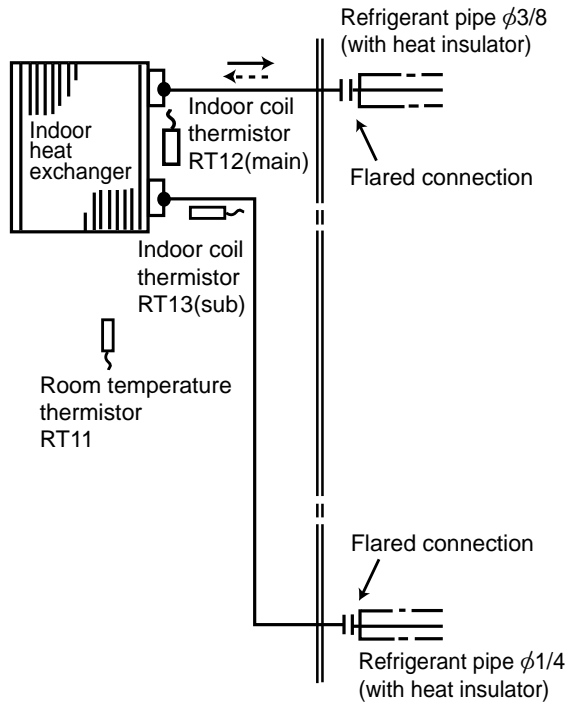

**MSZ-A15NA** **MSY-A15NA**  
**MSZ-A17NA** **MSY-A17NA**

Unit:inch

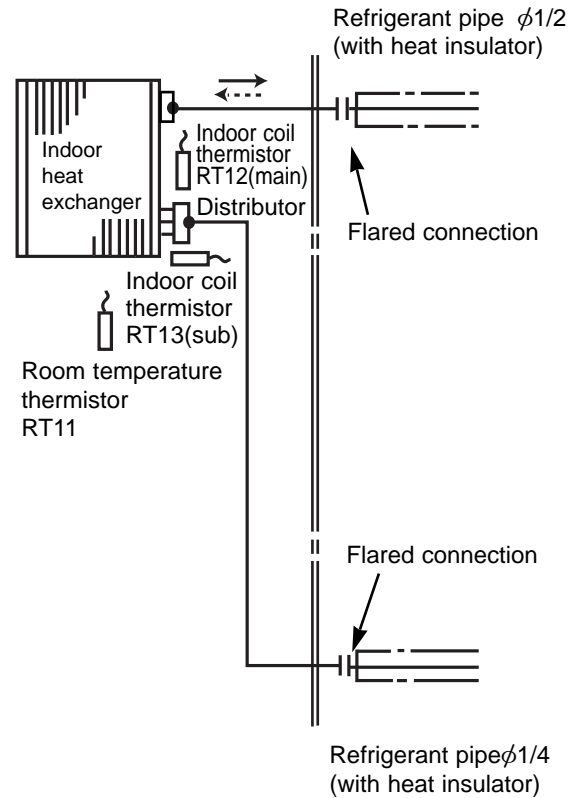

**MSZ-A24NA**  
**MSY-A24NA**

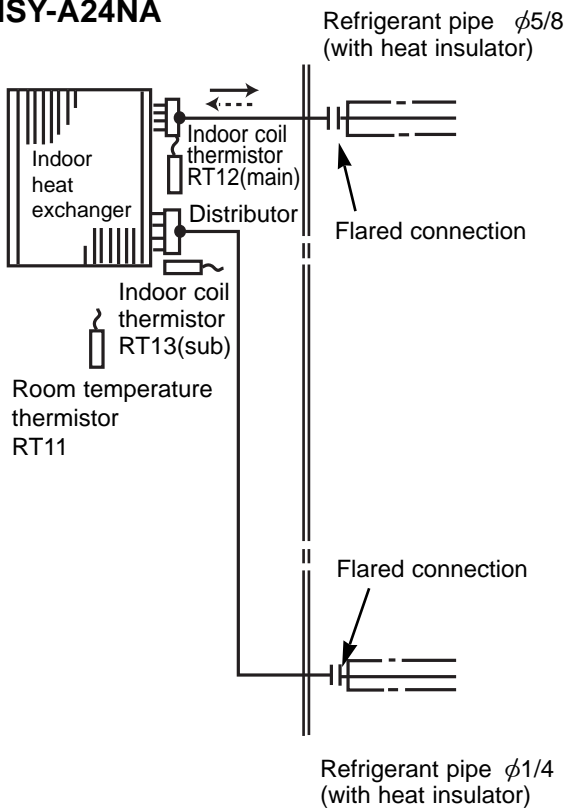

→ Refrigerant flow in cooling  
- - - - - → Refrigerant flow in heating

**MSZ-A09NA MSZ-A12NA MSZ-A15NA MSZ-A17NA MSZ-A24NA  
MSY-A15NA MSY-A17NA MSY-A24NA**

**7-1. TIMER SHORT MODE**

For service, set time can be shortened by short circuit of JPG and JPS the indoor electronic control P.C. board.

The time will be shortened as follows. (Refer to 8-7.)

Set time : 1-minute → 1-second

Set time : 3-minute → 3-second (It takes 3 minutes for the compressor to start operation. However, the starting time is shortened by short circuit of JPG and JPS.)

**7-2. P.C. BOARD MODIFICATION FOR INDIVIDUAL OPERATION**

A maximum of 4 indoor units with wireless remote controllers can be used in a room.

In this case, to operate each indoor unit individually by each remote controller, P.C. boards of remote controller must be modified according to the number of the indoor unit.

**How to modify the remote controller P.C. board**

Remove batteries before modification.

The board has a print as shown below :

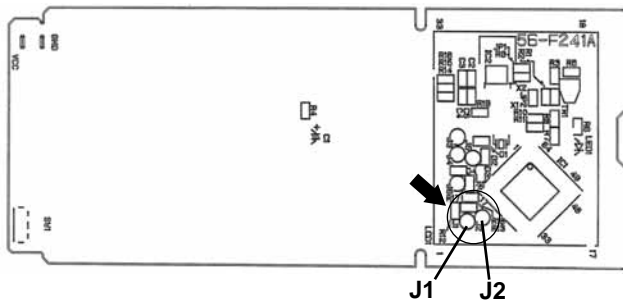

**NOTE :** For remodelling, take out the batteries and press the OPERATE/STOP(ON/OFF) button twice or 3 times at first.

After finish remodelling, put back the batteries then press the RESET button.

The P.C. board has the print "J1" and "J2". Solder "J1" and "J2" according to the number of indoor unit as shown in Table 1. After modification, press the RESET button.

**Table 1**

	1 unit operation	2 units operation	3 units operation	4 units operation
No. 1 unit	No modification	Same as at left	Same as at left	Same as at left
No. 2 unit	—	Solder J1	Same as at left	Same as at left
No. 3 unit	—	—	Solder J2	Same as at left
No. 4 unit	—	—	—	Solder both J1 and J2

**How to set the remote controller exclusively for particular indoor unit.**

After you turn the breaker ON, the first remote controller that sends the signal to the indoor unit will be regarded as the remote controller for the indoor unit.

The indoor unit will only accept the signal from the remote controller that has been assigned to the indoor unit once they are set.

The setting will be cancelled if the breaker has turned off, or the power supply has shut down.

Please conduct the above setting once again after the power has restored.

### 7-3. AUTO RESTART FUNCTION

When the indoor unit is controlled with the remote controller, the operation mode, the set temperature, and the fan speed are memorized by the indoor electronic control P.C. board. The "AUTO RESTART FUNCTION" sets to work the moment power has restored after power failure. Then, the unit will restart automatically.

#### Operation

- ① If the main power has been cut, the operation settings remain.
- ② After the power is restored, the unit restarts automatically according to the memory.  
(However, it takes at least 3 minutes for the compressor to start running.)

#### How to release "AUTO RESTART FUNCTION"

- ① Turn off the main power of the unit.
- ② Solder the Jumper wire JR07 on the indoor electronic control P.C. board. (Refer to 8-7.)

**MSZ-A09/12/15/17NA**  
**MSY-A15/17NA**

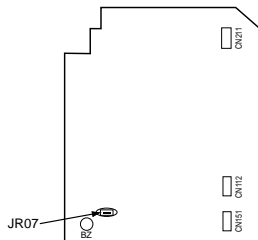

**MSZ-A24NA**  
**MSY-A24NA**

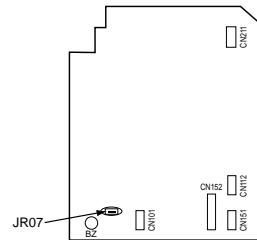

#### NOTE:

- The operation settings are memorized when 10 seconds have passed after the indoor unit was operated with the remote controller.
- If main power is turned OFF or a power failure occurs while AUTO START/STOP timer is active, the timer setting is cancelled.
- If the unit has been off with the remote controller before power failure, the auto restart function does not work as the power button of the remote controller is off.
- To prevent breaker off due to the rush of starting current, systematize other home appliance not to turn on at the same time.
- When some air conditioners are connected to the same supply system, if they are operated before power failure, the starting current of all the compressors may flow simultaneously at restart. Therefore, the special counter-measures are required to prevent the main voltage-drop or the rush of the starting current by adding to the system that allows the units to start one by one.

## 8

## TROUBLESHOOTING

**MSZ-A09NA MSZ-A12NA MSZ-A15NA MSZ-A17NA MSZ-A24NA**  
**MSY-A15NA MSY-A17NA MSY-A24NA**

### 8-1. Cautions on troubleshooting

#### 1. Before troubleshooting, check the following:

- 1) Check the power supply voltage.
- 2) Check the indoor/outdoor connecting wire for mis-wiring.

#### 2. Take care the following during servicing.

- 1) Before servicing the air conditioner, be sure to turn off the unit first with the remote controller, and then after confirming the horizontal vane is closed, turn off the breaker and / or disconnect the power plug.
- 2) Be sure to turn OFF the power supply before removing the front panel, the cabinet, the top panel, and the electronic control P.C. board.
- 3) When removing the electronic control P.C. board, hold the edge of the board with care NOT to apply stress on the components.
- 4) When connecting or disconnecting the connectors, hold the housing of the connector. DO NOT pull the lead wires.

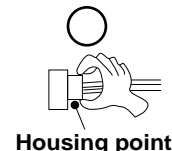
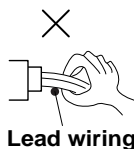

### 3. Troubleshooting procedure

- 1) First, check if the OPERATION INDICATOR lamp on the indoor unit is flashing on and off to indicate an abnormality. To make sure, check how many times the abnormality indication is flashing on and off before starting service work.
- 2) Before servicing check that the connector and terminal are connected properly.
- 3) If the electronic control P.C. board is supposed to be defective, check the copper foil pattern for disconnection and the components for bursting and discoloration.
- 4) When troubleshooting, refer to 8-2., 8-3. and 8-4.

### 4. How to replace batteries

Weak batteries may cause the remote controller malfunction.  
In this case, replace the batteries to operate the remote controller normally.

- ① Remove the front lid and insert batteries.  
Then reattach the front lid.

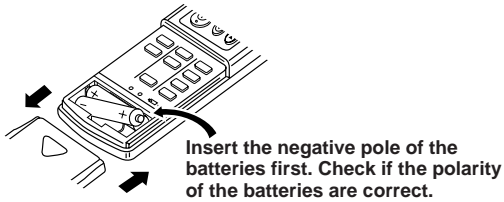

- ② Press RESET button with tip end of ball point pen or the like, and then use the remote controller.

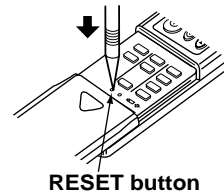

- NOTE :**
1. If RESET button is not pressed, the remote controller may not operate correctly.
  2. This remote controller has a circuit to automatically reset the microcomputer when batteries are replaced. This function is equipped to prevent the microcomputer from malfunctioning due to the voltage drop caused by the battery replacement.

### INFORMATION FOR MULTI SYSTEM AIR CONDITIONER

#### OUTDOOR UNIT : MXZ series

Multi system air conditioner can connect two or more indoor units with one outdoor unit.

- Unit won't operate in case the total capacity of indoor units exceeds the capacity of outdoor units. Do not connect indoor units beyond the outdoor unit capacity. Operation indicator lamp flashes as shown in the figure below.
- When you try to operate two or more indoor units with one outdoor unit simultaneously, one for the cooling and the other for heating, the operation mode of the indoor unit that operates earlier is selected. The other indoor units will start the operation later cannot operate, indicating as shown in the figure below. In this case, please set all the indoor units to the same operation mode.

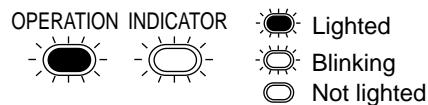

- When indoor units starts the operation while the defrosting of outdoor unit is being done, it takes a few minutes (max. 10 minutes) to blow out the warm air.
- In the heating operation, though indoor unit that does not operate may get warm or the sound of refrigerant flowing may be heard, they are not malfunction. The reason is that the refrigerant continuously flows into it.

## 8-2. Failure mode recall function

Outline of the function

This air conditioner can memorize the abnormal condition which has occurred once.

Even though LED indication listed on the troubleshooting check table (8-4.) disappears, the memorized failure details can be recalled.

This mode is very useful when the unit needs to be repaired for the abnormality which doesn't recur.

### 1. Flow chart of failure mode recall function for the indoor/outdoor unit

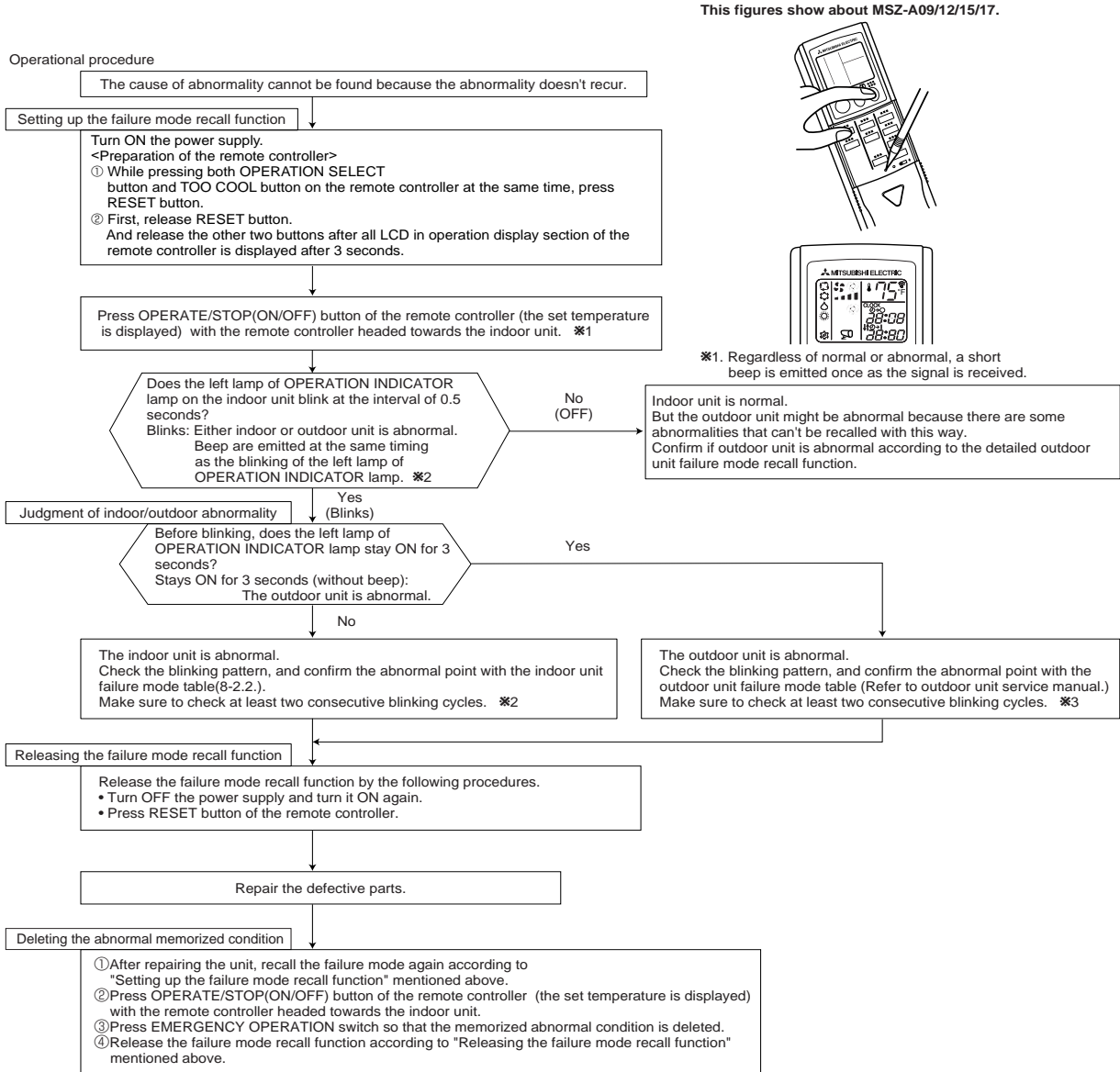

Note1. Make sure to release the failure mode recall function once it's set up, otherwise the unit cannot operate properly.  
2. If the abnormal condition is not deleted from the memory, the last abnormal condition is kept memorized.

\*2. Blinking pattern when the indoor unit is abnormal:

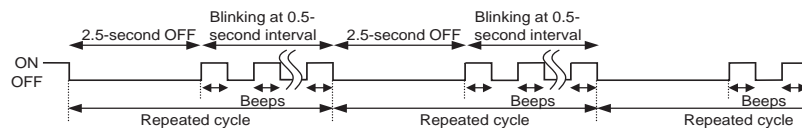

\*3. Blinking pattern when the outdoor unit is abnormal:

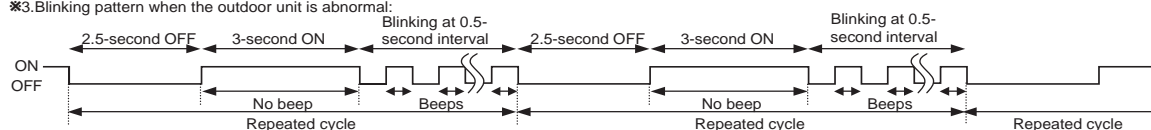

## 2. Indoor unit failure mode table

Left lamp of OPERATION INDICATOR lamp	Abnormal point (Failure mode)	Condition	Correspondence
Not lighted	Normal	—	—
1-time flash every 0.5-second	Room temperature thermistor	When the room temperature thermistor short or open circuit is detected every 8 seconds during operation.	Refer to the characteristics of the room temperature thermistor (8-7.).
2-time flash 2.5-second OFF	Indoor coil thermistor	When the indoor coil thermistor short or open circuit is detected every 8 seconds during operation.	Refer to the characteristics of the main indoor coil thermistor, the sub indoor coil thermistor (8-7.).
3-time flash 2.5-second OFF	Serial signal	When the serial signal from outdoor unit is not received for a maximum of 6 minutes.	Refer to 8-6.Ⓒ "How to check mis-wiring and serial signal error".
11-time flash 2.5-second OFF	Indoor fan motor	When the rotational frequency feedback signal is not emit during the 12-seconds the indoor fan operation.	Refer to 8-6.Ⓓ "Check of indoor fan motor".
12-time flash 2.5-second OFF	Indoor control system	When it cannot properly read data in the nonvolatile memory of the indoor electronic control P.C. board.	Replace the indoor electronic control P.C. board.

**NOTE :** Blinking patterns of this mode differ from the ones of Troubleshooting check table (8-4.).

### 8-3. Instruction of troubleshooting

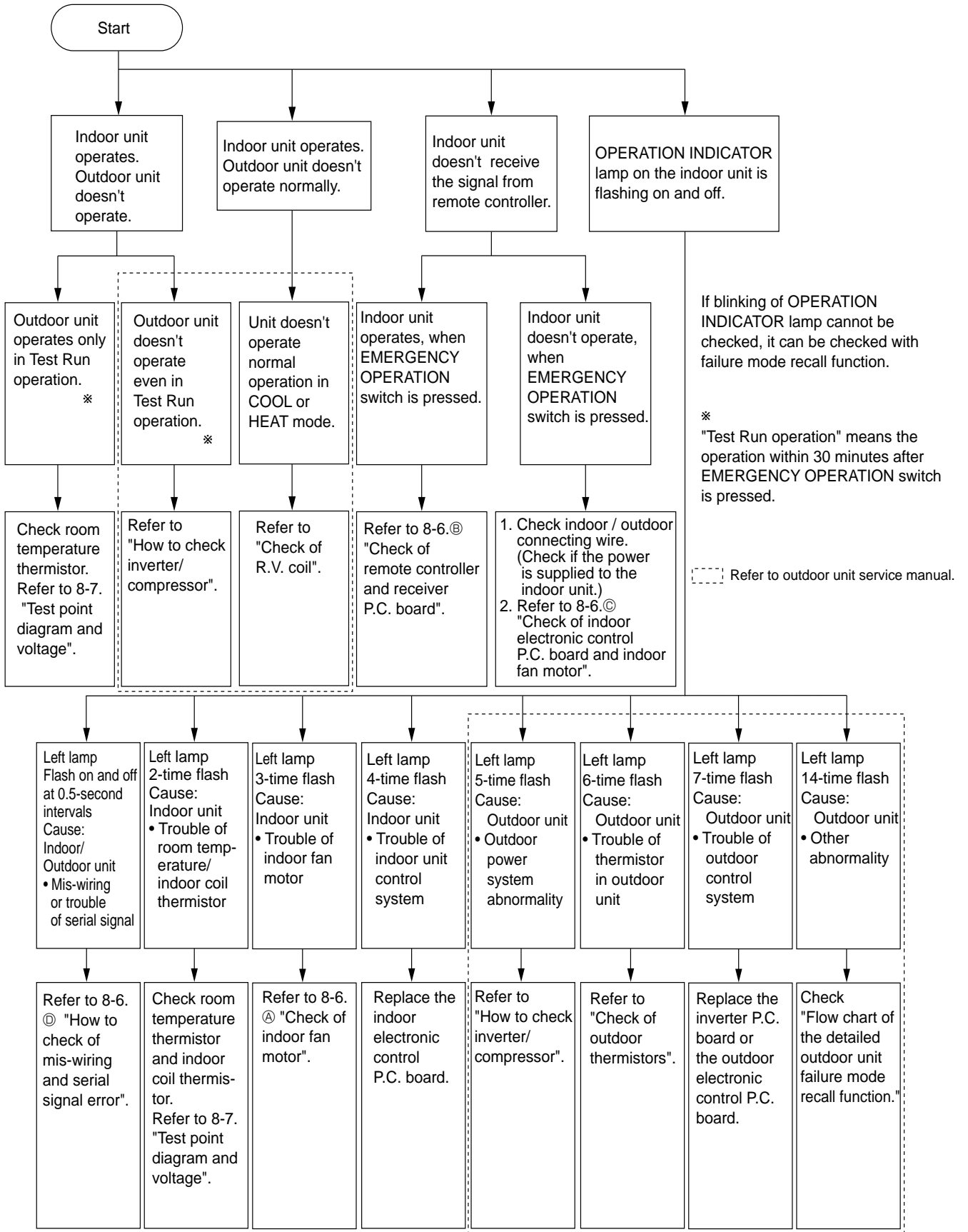

## 8-4. Troubleshooting check table

Before taking measures, make sure that the symptom reappears for accurate troubleshooting. When the indoor unit has started operation and the following detection method has detected an abnormality (the first detection after the power ON), the indoor electronic control P.C. board turns OFF the indoor fan motor with OPERATION INDICATOR lamp flashing.

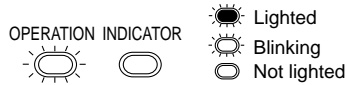

· Flashing of OPERATION INDICATOR lamp (left-hand side lamp) indicates abnormalities.

No.	Abnormal point	Operation indicator lamp	Symptom	Condition	Correspondence
1	Mis-Wiring or serial signal	Left lamp flashes. 0.5-second ON ● ○ ● ○ ● ○ ● ○ 0.5-second OFF	Indoor unit and outdoor unit do not operate.	When the serial signal from the outdoor unit is not received for a maximum of 6 minutes.	<ul style="list-style-type: none"> <li>Refer to 8-6.⑥ "How to check mis-wiring and serial signal error".</li> </ul>
2	Outdoor control system MSZ-A09/12 MSZ-A15/17 MSY-A15/17	Left lamp lights up ●	Outdoor unit does not operate.	When it cannot properly read data in the nonvolatile memory of the inverter P.C. board or the outdoor electronic control P.C. board.	<ul style="list-style-type: none"> <li>Check the blinking pattern of the LED on the inverter P.C. board or the outdoor electronic control P.C. board.</li> </ul>
3	Indoor coil thermistor Room temperature thermistor	Left lamp flashes. 2-time flash ● ● ○ ○ ○ ○ ● ● ○ ○ 2.5-second OFF	Indoor unit and outdoor unit do not operate.	When the indoor coil or the room temperature thermistor is short or open circuit.	<ul style="list-style-type: none"> <li>Refer to 8-7.the characteristics of indoor coil thermistor, and the room temperature thermistor.</li> </ul>
4	Indoor fan motor	Left lamp flashes. 3-time flash ● ● ● ○ ○ ○ ● ● ● ○ ○ ○ 2.5-second OFF	Indoor unit and outdoor unit do not operate.	When the rotational frequency feedback signal is not emitted during the indoor fan operation.	<ul style="list-style-type: none"> <li>Refer to 8-6.⑧ "Check of indoor fan motor".</li> </ul>
5	Indoor control system	Left lamp flashes. 4-time flash ● ● ● ● ○ ○ ○ ○ ● ● ● ● 2.5-second OFF	Indoor unit and outdoor unit do not operate.	When it cannot properly read data in the nonvolatile memory of the indoor electronic control P.C. board.	<ul style="list-style-type: none"> <li>Replace the indoor electronic control P.C. board.</li> </ul>
6	Outdoor power system	Left lamp flashes. 5-time flash ● ● ● ● ● ○ ○ ○ ○ ○ ● ● ● ● 2.5-second OFF	Indoor unit and outdoor unit do not operate.	When it consecutively occurs 3 times that the compressor stops for overcurrent protection or start-up failure protection within 1 minute after start-up.	<ul style="list-style-type: none"> <li>Refer to "How to check of inverter/ compressor". Refer to outdoor unit service manual.</li> <li>Check the stop valve.</li> </ul>
7	Outdoor thermistors	Left lamp flashes. 6-time flash ● ● ● ● ● ● ○ ○ ○ ○ ○ ○ ● ● ● ● 2.5-second OFF	Indoor unit and outdoor unit do not operate.	When the outdoor thermistors short or open circuit during the compressor operation.	<ul style="list-style-type: none"> <li>Refer to "Check of outdoor thermistor". Refer to outdoor unit service manual.</li> </ul>
8	Outdoor control system	Left lamp flashes. 7-time flash ● ● ● ● ● ● ● ○ ○ ○ ○ ○ ○ ● ● ● ● ● ● 2.5-second OFF	Indoor unit and outdoor unit do not operate.	When it cannot properly read data in the nonvolatile memory of the inverter P.C. board or the outdoor electronic control P.C. board.	<ul style="list-style-type: none"> <li>Replace the inverter P.C. board or the outdoor electronic control P.C. board. Refer to outdoor unit service manual.</li> </ul>
9	Other abnormality	Left lamp flashes. 14-time flash ● ● ● ● ● ● ● ● ● ● ● ● ● ● ● ● ○ ○ ○ ○ ○ ○ ● ● ● ● ● ● ● ● ● ● ● ● 2.5-second OFF	Indoor unit and outdoor unit do not operate.	An abnormality other than above mentioned is detected.	<ul style="list-style-type: none"> <li>Confirm the abnormality in detail using the failure mode recall function for outdoor unit.</li> </ul>

OPERATION INDICATOR



Lighted

Blinking

Not lighted

· Flashing of OPERATION INDICATOR lamp (right-hand side lamp) indicates abnormality.

· OPERATION INDICATOR lamp (left-hand side lamp) is lighted.

No.	Abnormal point	Operation indicator lamp	Symptom	Condition	Correspondence
1	<b>MXZ type</b> Operation mode setting	<p><b>Right lamp flash</b></p> <p>2.5-second OFF</p>	Outdoor unit operates but indoor unit does not operate.	When the operation mode of the each indoor unit is differently set to COOL(includes DRY) and HEAT at the same time, the operation mode of the indoor unit that has operated at first has the priority.	<ul style="list-style-type: none"> <li>Unify the operation mode. Refer to outdoor unit service manual.</li> </ul>

**8-5. Trouble criterion of main parts**

**MSZ-A09NA MSZ-A12NA MSZ-A15NA**  
**MSZ-A17NA MSZ-A24NA**  
**MSY-A15NA MSY-A17NA MSY-A24NA**

Part name	Check method and criterion	Figure				
Room temperature thermistor(RT11)	Measure the resistance with a tester.	/				
Indoor coil thermistor (RT12(MAIN), RT13(SUB))	Refer to 8-7. "Test point diagram and voltage", "Indoor electronic control P.C. board", the chart of thermistor.					
Indoor fan motor(MF)	Check 8-6. ㉔.	/				
Horizontal vane motor(MV) <b>MSZ-A09/12/15/17NA</b> <b>MSY-A15/17NA</b>	<p>Measure the resistance between the terminals with a tester. (Part temperature 50°F ~ 86°F)</p> <table border="1"> <tr> <td>Color of the lead wire</td> <td>Normal</td> </tr> <tr> <td>BRN-other one</td> <td>235 Ω ~ 255 Ω</td> </tr> </table>	Color of the lead wire	Normal	BRN-other one	235 Ω ~ 255 Ω	
Color of the lead wire	Normal					
BRN-other one	235 Ω ~ 255 Ω					
Horizontal vane motor(MV1) Vertical vane motor(MV2) <b>MSZ-A24NA</b> <b>MSY-A24NA</b>	<p>Measure the resistance between the terminals with a tester. (Part temperature 50°F ~ 86°F)</p> <table border="1"> <tr> <td>Color of the lead wire</td> <td>Normal</td> </tr> <tr> <td>BRN-other one</td> <td>282 Ω ~ 306 Ω</td> </tr> </table>	Color of the lead wire	Normal	BRN-other one	282 Ω ~ 306 Ω	
Color of the lead wire	Normal					
BRN-other one	282 Ω ~ 306 Ω					

## 8-6. Troubleshooting flow

When OPERATION INDICATOR lamp flashes 3-time.  
Indoor fan does not operate.

### A Check of indoor fan motor

The indoor fan motor error has occurred, and the indoor fan doesn't operate.

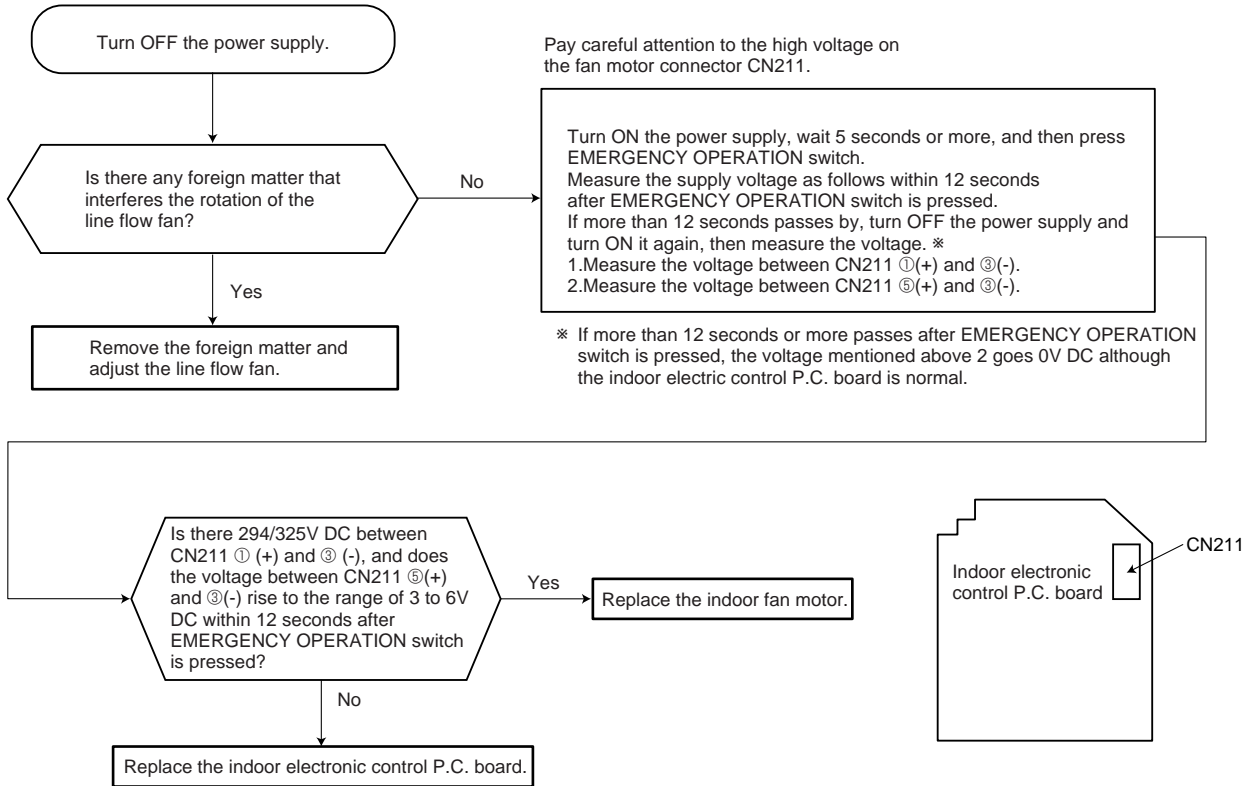

The indoor fan motor error has occurred, and the indoor fan repeats "12-second ON and 30-second OFF" 3times, and then stops.

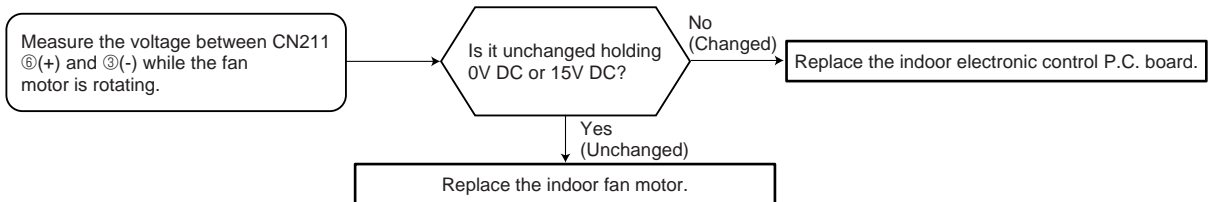

Indoor unit operates by pressing EMERGENCY OPERATION switch, but does not operate with the remote controller.

**Ⓑ Check of remote controller and receiver P.C. board**

\*Check if the remote controller is exclusive for this air conditioner.

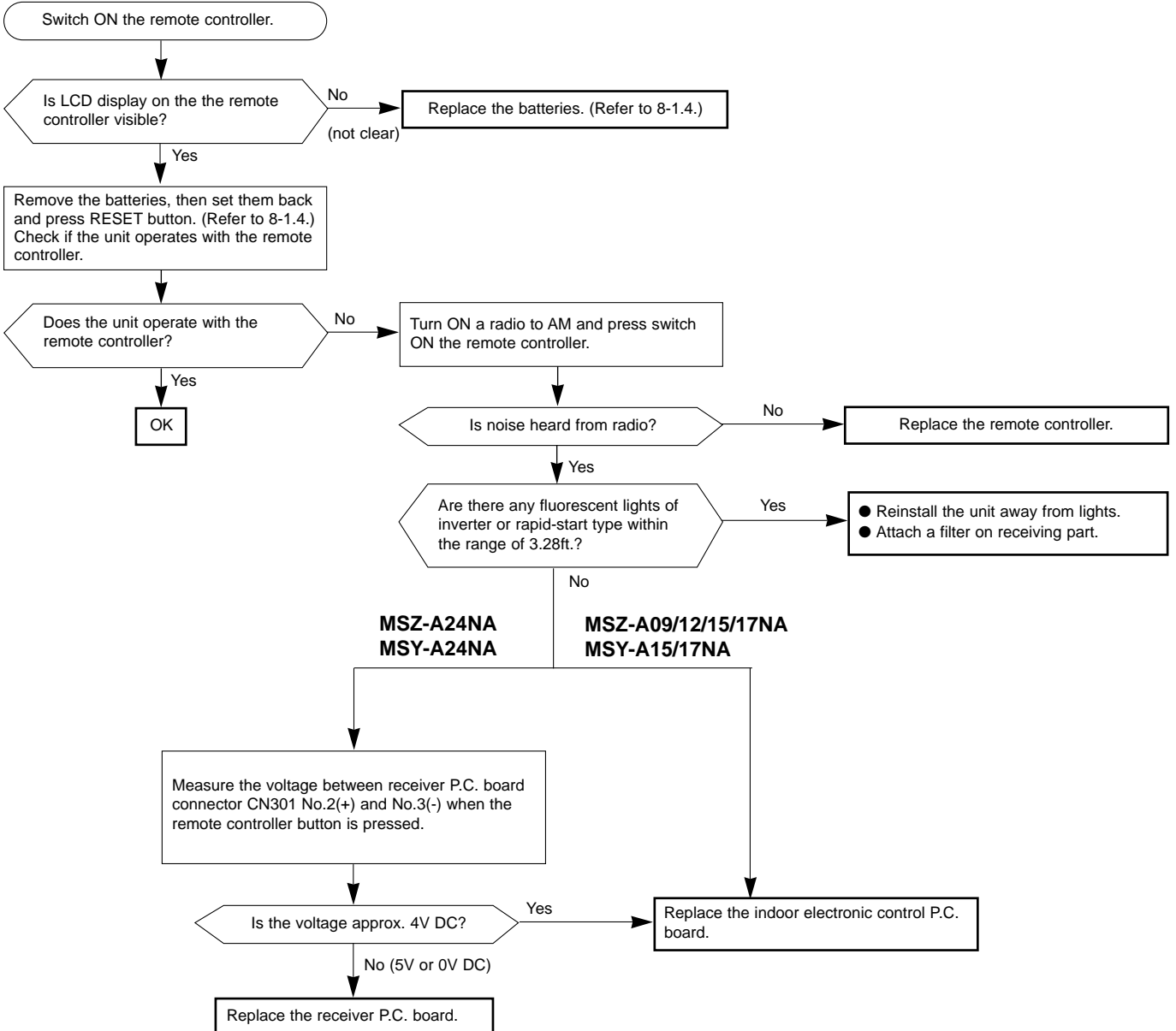

The unit does not operate with the remote controller.  
 Also, OPERATION INDICATOR lamp does not light up by pressing EMERGENCY OPERATION switch.

**© Check of indoor electronic control P.C. board and indoor fan motor**

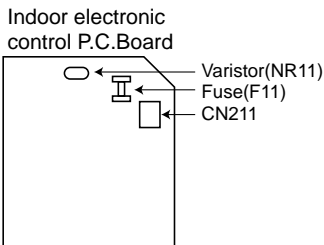
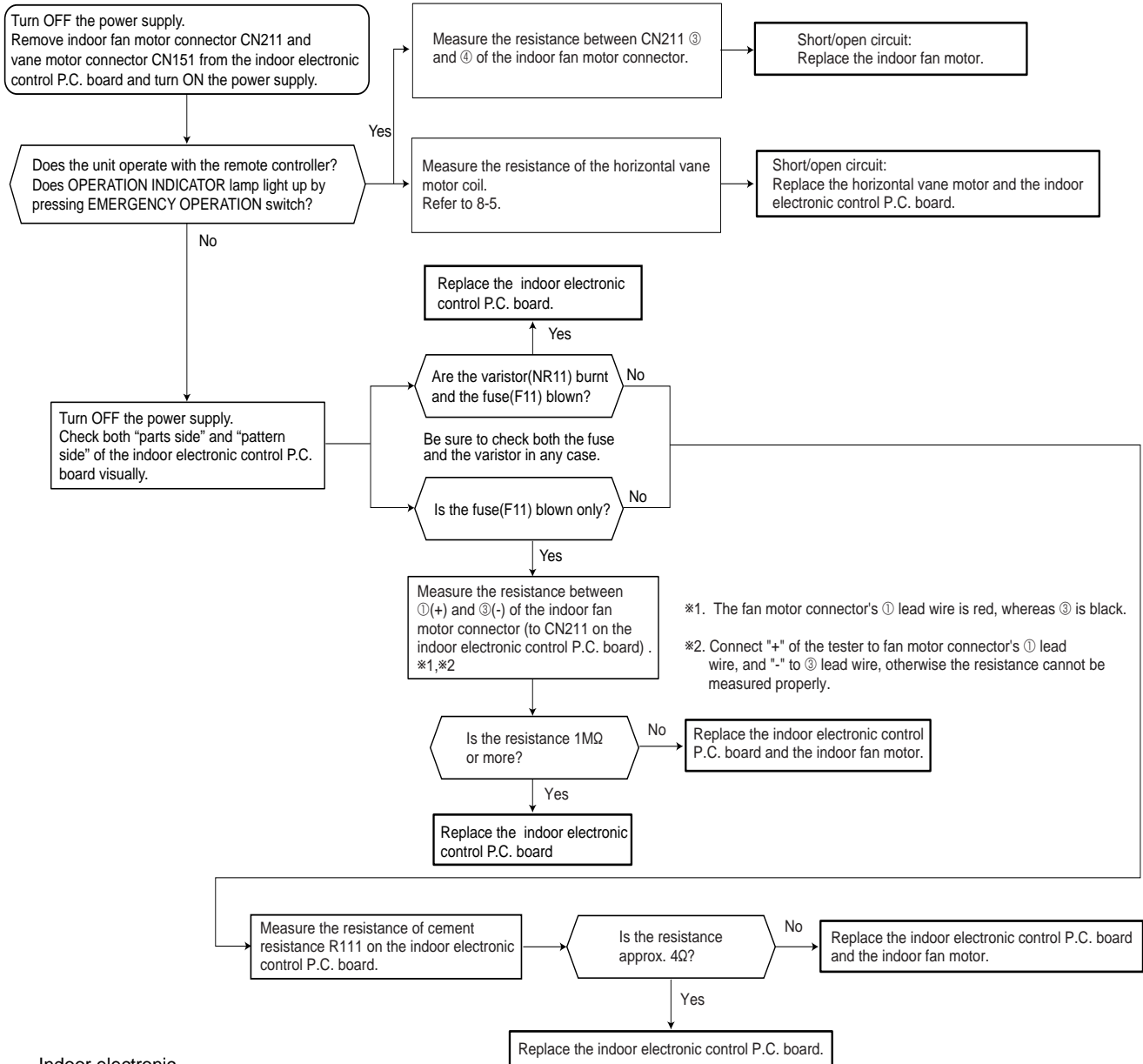

- When unit cannot operate neither by the remote controller nor by EMERGENCY OPERATION switch. Indoor unit does not operate.
- When OPERATION INDICATOR lamp flashes ON and OFF in every 0.5-second. Outdoor unit does not operate.

### D How to check mis-wiring and serial signal error

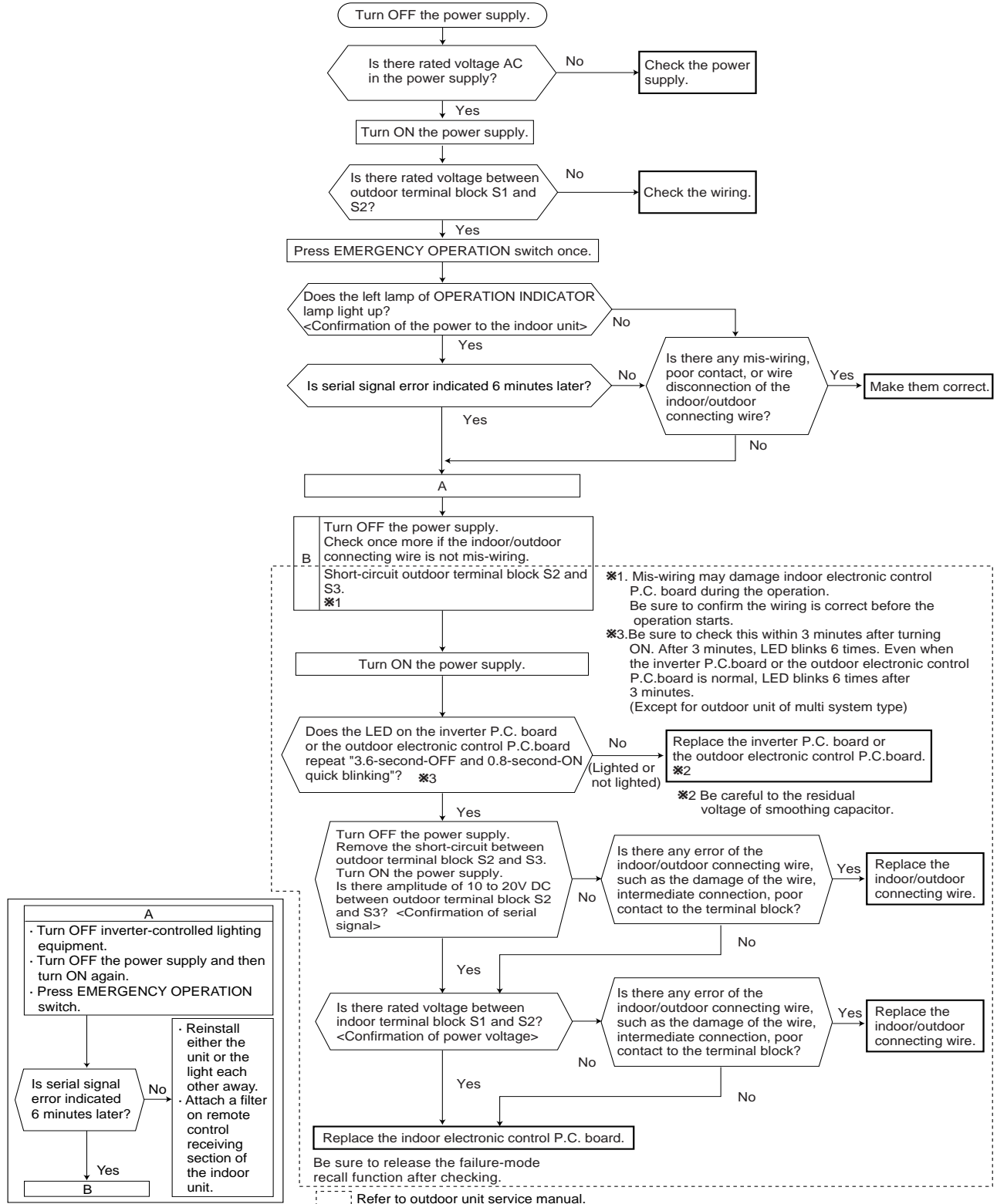

## E Electromagnetic noise enters into TV sets or radios

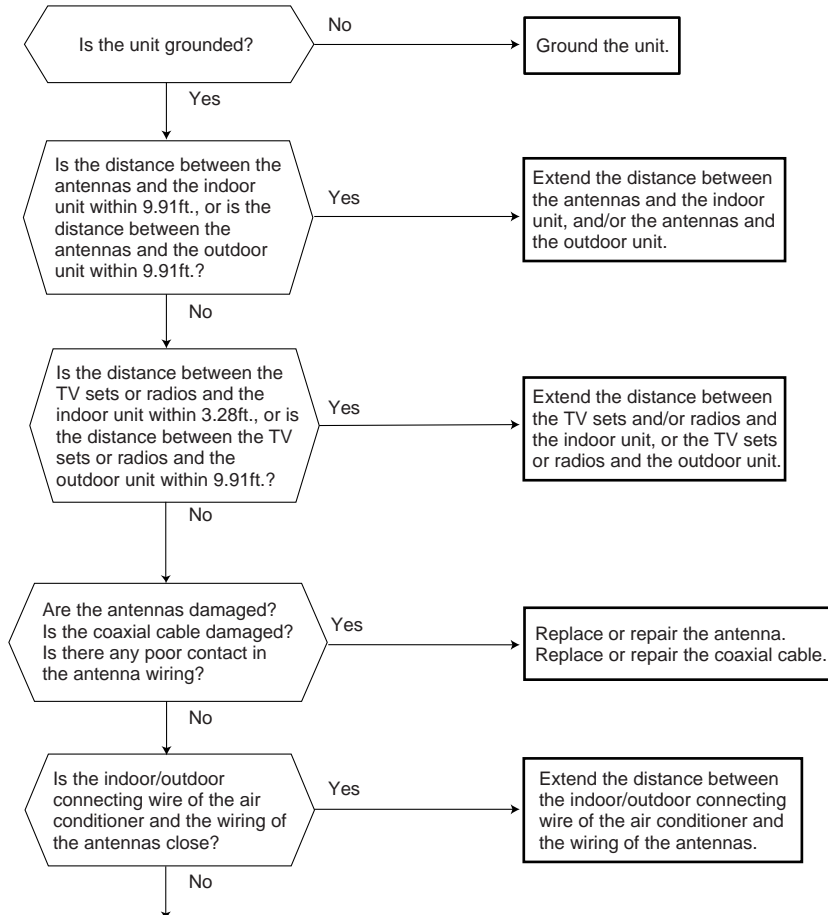

Even if all of the above conditions is fulfilled, the electromagnetic noise may enter, depending on the electric field strength or the installation condition (combination of specific conditions such as antennas or wiring).

Check the followings before asking for service.

- 1.Devices affected by the electromagnetic noise  
TV sets, radios (FM/AM broadcast, shortwave)
- 2.Channel, frequency, broadcast station affected by the electromagnetic noise
- 3.Channel, frequency, broadcast station unaffected by the electromagnetic noise
- 4.Layout of ;  
indoor/outdoor unit of the air conditioner, indoor/outdoor wiring, grounding wire, antennas, wiring from antennas, receiver
- 5.Electric field intensity of the broadcast station affected by the electromagnetic noise
- 6.Presence or absence of amplifier such as booster
- 7.Operation condition of air conditioner when the electromagnetic noise enters in.

- 1)Turn OFF the power supply once, and then turn ON the power supply. In this situation check for the electromagnetic noise.
- 2)Within 3 minutes after turning ON the power supply, press OPERATE/STOP (ON/OFF) button on the remote controller for power ON, and check for the electromagnetic noise.
- 3)After a short time (3 minutes later after turning ON), the outdoor unit starts running. During operation, check for the electromagnetic noise.
- 4)Press OPERATE/STOP (ON/OFF) button on the remote controller for power OFF, when the outdoor unit stops but the indoor/outdoor communication still runs on. In this situation check for the electromagnetic noise.

After checking the above, consult the service representative.



**MSZ-A24NA MSY-24NA**  
Indoor electronic control P.C. board

Release of Auto restart function  
Solder the Jumper wire to JR07.  
(Refer to 6-3.)

Varistor (NR11) Power supply input 208/230V AC Fuse(F11)

Display P.C. board.

Indoor fan motor (CN211)  
① 294/325V DC  
③ (-) Fiducial terminal of cathode side on measuring high-voltage DC  
④ 15V DC  
⑤ (+) 3-6V DC  
⑥ (+) 0V DC or 15V DC

5V DC

Indoor coil thermistor RT12(MAIN) RT13(SUB)

Horizontal vane motor(CN151)

Room temperature thermistor(RT11)

Timer short mode point JPG, JPS (Refer to 7-1.)

12V DC Vertical vane motor (CN152)

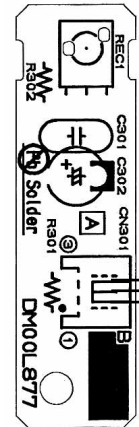

Receiver P.C. board.

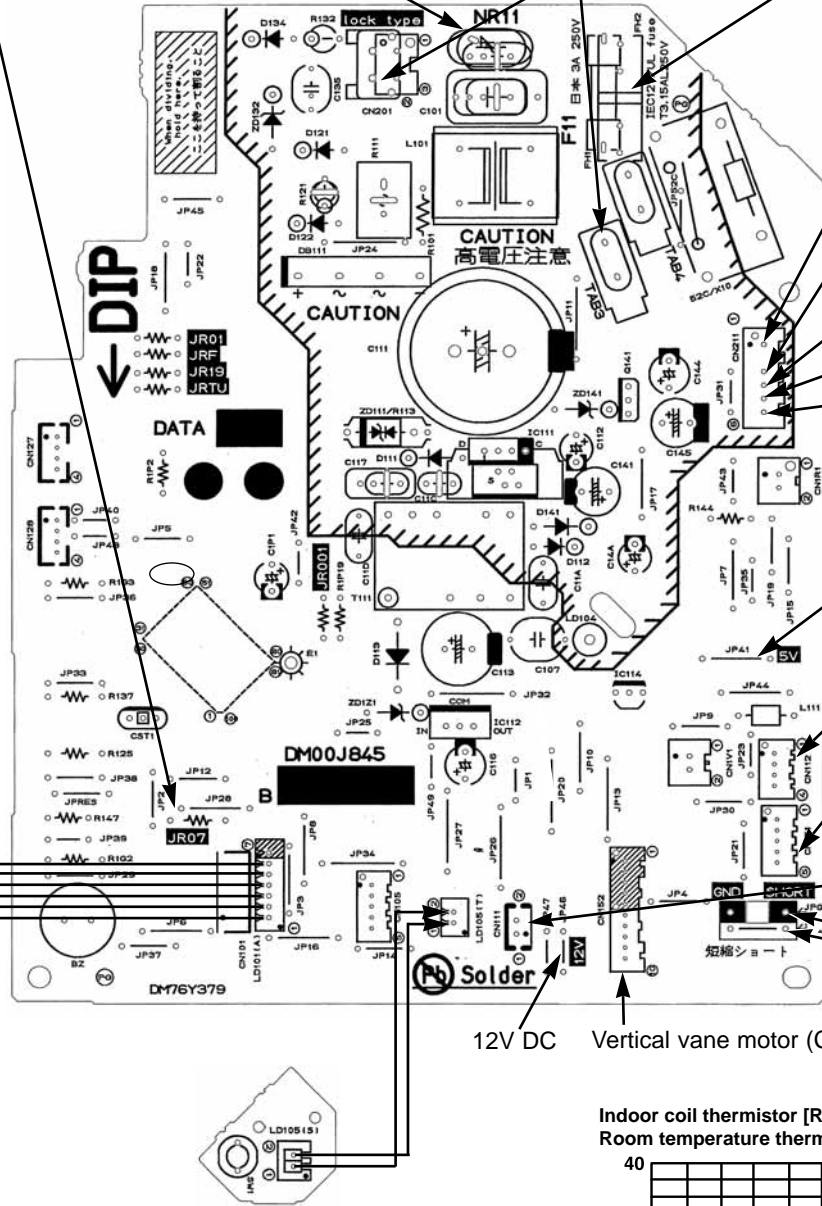

SW P.C. board

Indoor coil thermistor [RT12 (MAIN), RT13 (SUB)]  
Room temperature thermistor (RT11)

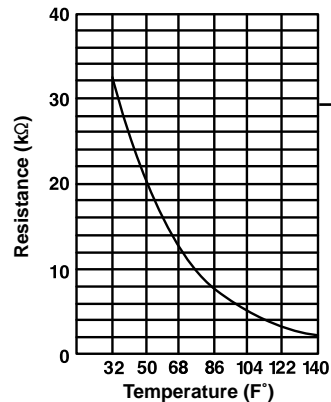

## &lt;"Terminal with locking mechanism" Detaching points&gt;

The terminal which has the locking mechanism can be detached as shown below.  
There are two types ( Refer to (1) and (2)) of the terminal with locking mechanism.  
The terminal without locking mechanism can be detached by pulling it out.  
Check the shape of the terminal before detaching.

(1) Slide the sleeve and check if there is a locking lever or not.

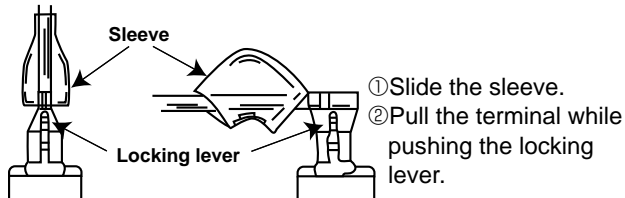

(2) The terminal with this connector has the locking mechanism.

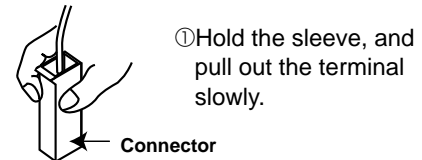

## 9-1. MSZ-A09NA MSZ-A12NA MSZ-A15NA MSZ-A17NA MSY-A15NA MSY-A17NA

OPERATING PROCEDURE	PHOTOS
<p><b>1. Removing the panel</b></p> <p>(1) Remove the horizontal vane.</p> <p>(2) Remove the screw caps of the panel. Remove the screws. (See Photo 1.)</p> <p>(3) Hold the lower part of both ends on the panel and pull it slightly toward you, and then remove the panel by pushing it upward.</p>	<p><b>Photo 1</b></p> <p>Horizontal vane</p> <p>Screws of the panel</p> <p><b>Photo 2</b></p> <p>Terminal block cover</p> <p>Conduit cover</p> <p>Screw of the conduit cover</p> <p>Conduit plate</p>

## OPERATING PROCEDURE

### 2. Removing the electronic control P.C. board, the power monitor receiver P.C. board, SW P.C. board and the terminal block

- (1) Remove the horizontal vane, the panel (Refer to 1.) and the corner box.
- (2) Remove the screw of the conduit cover, and conduit cover. (See Photo 2.)
- (3) Remove the indoor/outdoor connecting wire.
- (4) Remove the switch holder from the electrical cover. (See Photo 3.)
- (5) Remove the screw of the electrical cover, and then the electrical cover. (See Photo 3.)
- (6) Remove the ground wire connected to the indoor electronic control P.C. board from the electrical box. (See Photo 4.)
- (7) Unhook the power monitor receiver P.C. board holder from the catch. (See Photo 3.)
- (8) Open the rear cover of the power monitor receiver P.C. board holder and pull out the power monitor receiver P.C. board.
- (9) Open the switch holder and pull out SW P.C. board.
- (10) Pull the electronic control P.C. board slightly toward you from the electrical box, and disconnect TAB3 and all the connectors on the electronic control P.C. board. (LD101 and LD105 are direct-mounted to the electronic control P.C. board.)
- (11) Pull out the electronic control P.C. board from the electrical box.
- (12) Remove the ground wire connected to the heat exchanger from the electrical box. (See Photo 4.)
- (13) Unhook the catches of the electrical box, and pull out the electrical box.
- (14) Remove the screw of the terminal block cover, and then remove the terminal block cover and the terminal block holder. (See Photo 5)
- (15) Remove the terminal block by sliding it.

### 3. Removing the electrical box

- (1) Remove the horizontal vane, the panel (Refer to 1.) and the corner box.
- (2) Remove the screw of Conduit cover, and then the indoor/outdoor connecting wire. (See Photo 2.)
- (3) Remove the switch holder and the electrical cover. (See Photo 3.)
- (4) Remove the ground wire connected to the heat exchanger from the electrical box. (See Photo 4.)
- (5) Disconnect the following connectors on the electronic control P.C. board; the fan motor connector <CN211>, the indoor coil thermistor connector <CN112>, the vane motor connector <CN151>.
- (6) Unhook the catches of the electrical box, and pull out the electrical box.

## PHOTOS

Photo 3

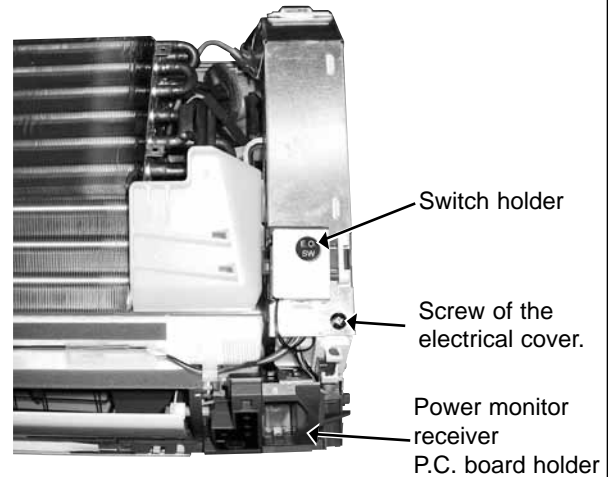

Photo 4

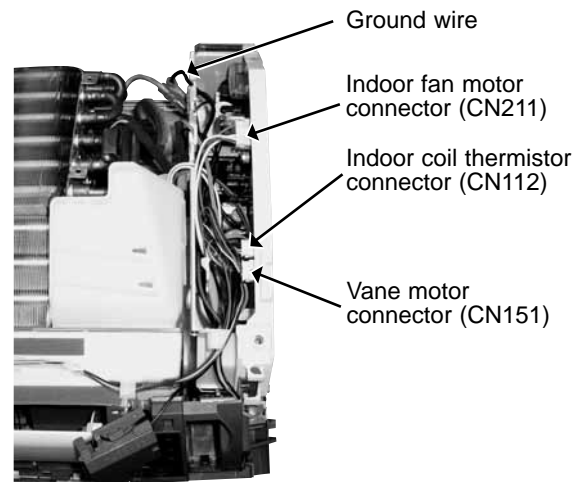
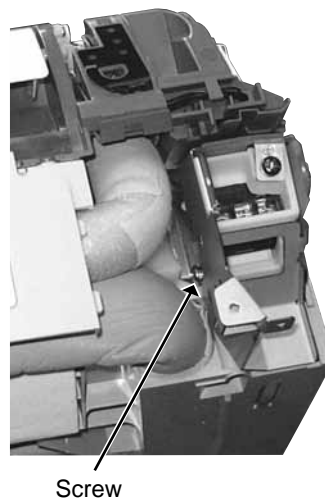

Photo 5





**OPERATING PROCEDURE**

**4. Removing the horizontal vane motor unit**

- (1) Remove the horizontal vane and the panel. (Refer to 1.)
- (2) Remove the screws of the horizontal vane motor unit, and pull out the horizontal vane motor unit. (See Photo 6.)
- (3) Disconnect the connector from the horizontal vane motor unit.

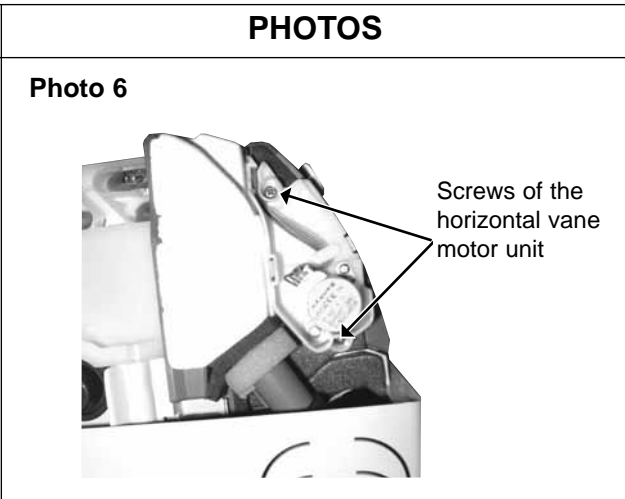

**5. Removing the indoor fan motor and the line flow fan**

- (1) Remove the horizontal vane, the panel (Refer to 1.) and the corner box.
- (2) Remove the switch holder and the electrical box. (Refer to 3.)
- (3) Remove the drain hose from the nozzle assembly, and remove the nozzle assembly.
- (4) Remove the screws fixing the motor bed. (See Photo 7.)
- (5) Loosen the screw fixing the line flow fan. (See Photo 8.)
- (6) Remove the motor bed together with fan motor and motor band.
- (7) Release the hooks of the motor band, and remove the motor band then pull out the indoor fan motor.
- (8) Remove the screws fixing the left side of the heat exchanger. (See Photo 9.)
- (9) Lift the heat exchanger, and pull out the line flow fan to the lower-left.

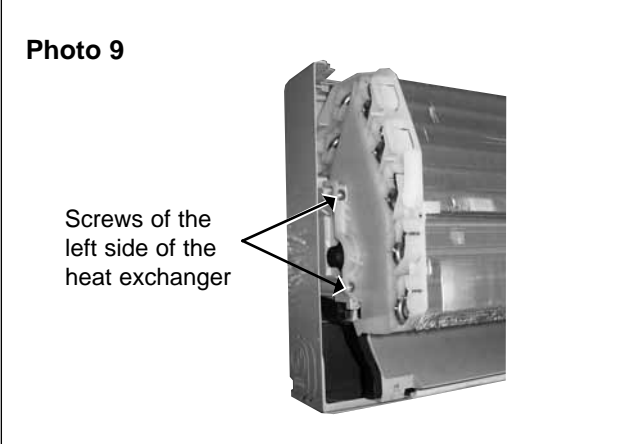
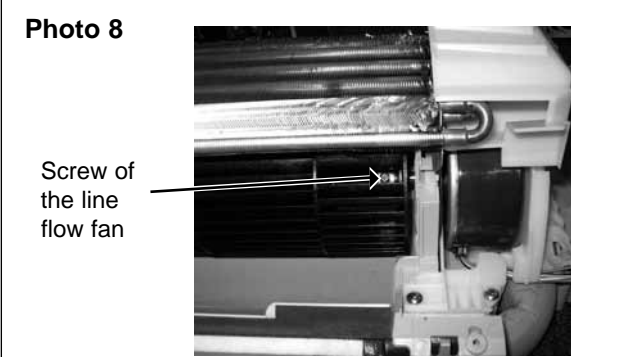
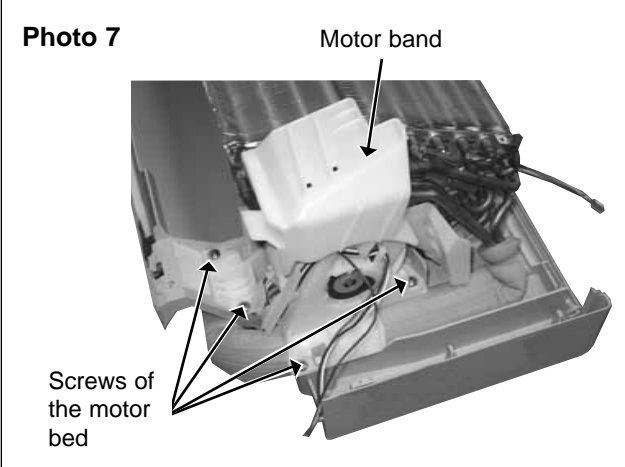

## 9-2.MSZ-A24NA MSY-A24NA

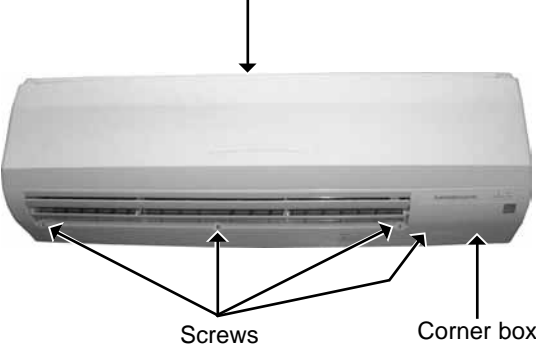
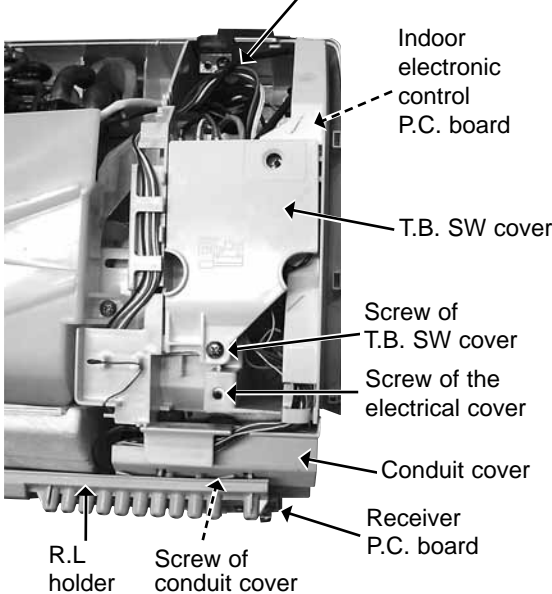
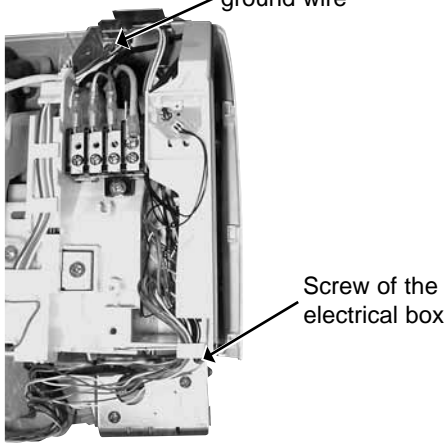
OPERATING PROCEDURE	PHOTOS
<p><b>1. Removing the front panel</b></p> <ol style="list-style-type: none"> <li>(1) Remove the screw caps of the front panel. Remove the screws.</li> <li>(2) Pull the panel down to your side slightly and unhook the catches at the top.</li> </ol>	<p><b>Photo 1</b></p>  <p>Labels in Photo 1: Front panel, Screws, Corner box.</p>
<p><b>2. Removing the electronic control P.C. board, the receiver P.C. board and the display P.C. board</b></p> <ol style="list-style-type: none"> <li>(1) Remove the front panel. (Refer to 1.)</li> <li>(2) Remove the corner box</li> <li>(3) Remove the screw of the electrical cover. Remove the electrical cover and T.B. SW cover.</li> <li>(4) Remove the screw of the ground wire, which is solder-mounted to the electronic control P.C. board.</li> <li>(5) Remove the R.L holder.</li> <li>(6) Remove the screw of the conduit cover.</li> <li>(7) Remove the conduit cover.</li> <li>(8) While pulling the electronic control P.C. board forward little by little, disconnect all the connectors from the board.</li> <li>(9) Remove the electronic control P.C. board.</li> <li>(10) Open the R.L holder, remove the receiver P.C. board and the display P.C. board.</li> </ol>	<p><b>Photo 2</b></p>  <p>Labels in Photo 2: Screw of the ground wire, Indoor electronic control P.C. board, T.B. SW cover, Screw of T.B. SW cover, Screw of the electrical cover, Conduit cover, Receiver P.C. board, R.L holder, Screw of conduit cover.</p>
<p><b>3. Removing the electrical box</b></p> <ol style="list-style-type: none"> <li>(1) Remove the front panel. (Refer to 1.)</li> <li>(2) Remove the electrical cover. (Refer to 2.)</li> <li>(3) Disconnect the connector of the indoor coil thermistors.</li> <li>(4) Disconnect the indoor fan motor connector (CN211) and the vane motor connector (CN151 and CN152) on the electronic control P.C. board.</li> <li>(5) Remove the screw of ground wire to the heat exchanger.</li> <li>(6) Remove the fan motor lead wire and indoor coil thermistor from the electrical box.</li> <li>(7) Remove the lead wire of vane motor from the bottom of electrical box.</li> <li>(8) Remove the screw fixing the electrical box and remove the electrical box.</li> </ol>	<p><b>Photo 3</b></p>  <p>Labels in Photo 3: Screw of the ground wire, Screw of the electrical box.</p>

## OPERATING PROCEDURE

### 4. Removing the vane motor

- (1) Remove the front panel. (Refer to 1.)
- (2) Remove the electrical cover. (Refer to 2.)
- (3) Remove the lead wire of vane motor.(Refer to 3.)
- (4) Remove the R.L. holder.
- (5) Pull out the drain hose from the nozzle assembly and remove the nozzle assembly.
- (6) Remove the screws of the vane motor and disconnect the connector.
- (7) Remove the vane motor.

**Photo 5**

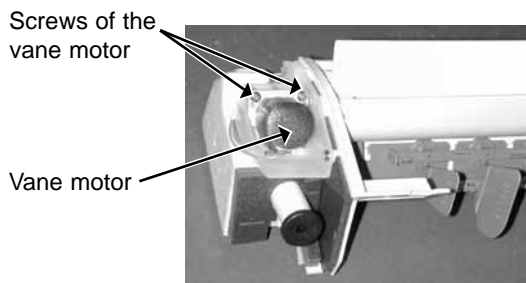

## PHOTOS

**Photo 4**

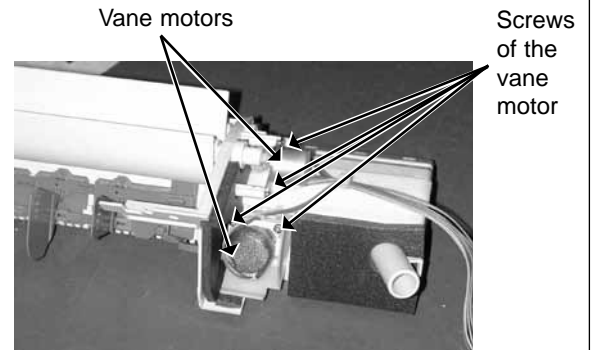

### 5. Removing the line flow fan and the indoor fan motor

- (1) Remove the front panel. (Refer to 1.)
- (2) Remove the electrical box. (Refer to 3.)
- (3) Remove the drain hose from the nozzle assembly and remove the nozzle assembly.
- (4) Remove the water cut.
- (5) Slide the hole cover and remove the hole cover.
- (6) Remove the hexagon socket set screw from the line flow fan.
- (7) Remove the screws fixing the motor bed and remove the fan motor. (Be careful not to drop the fan motor because it is heavy.)
- (8) Remove the screws fixing the left side of the heat exchanger.
- (9) Lift the left side of the heat exchanger.
- (10) Remove the line flow fan.

**Photo 8**

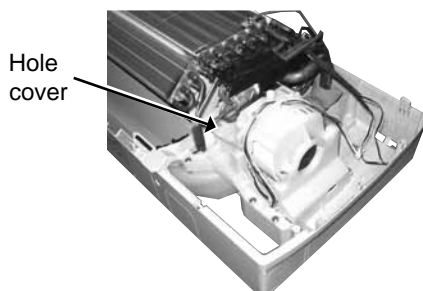

**Photo 6**

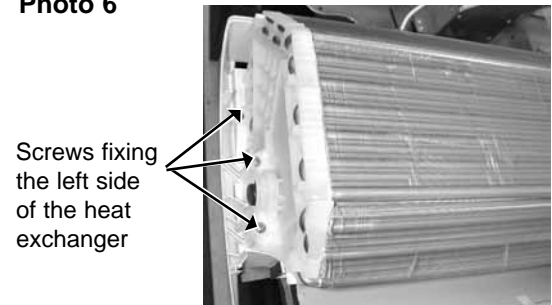

**Photo 7**

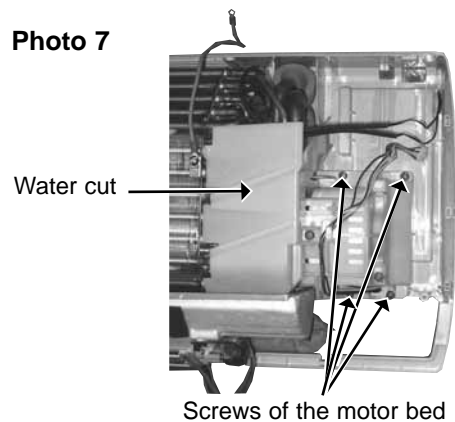

10-1. PARTS LIST (non-RoHS compliant)

MSZ-A09NA MSY-A15NA

MSZ-A12NA MSY-A17NA

MSZ-A15NA

MSZ-A17NA

1. INDOOR UNIT STRUCTURAL PARTS

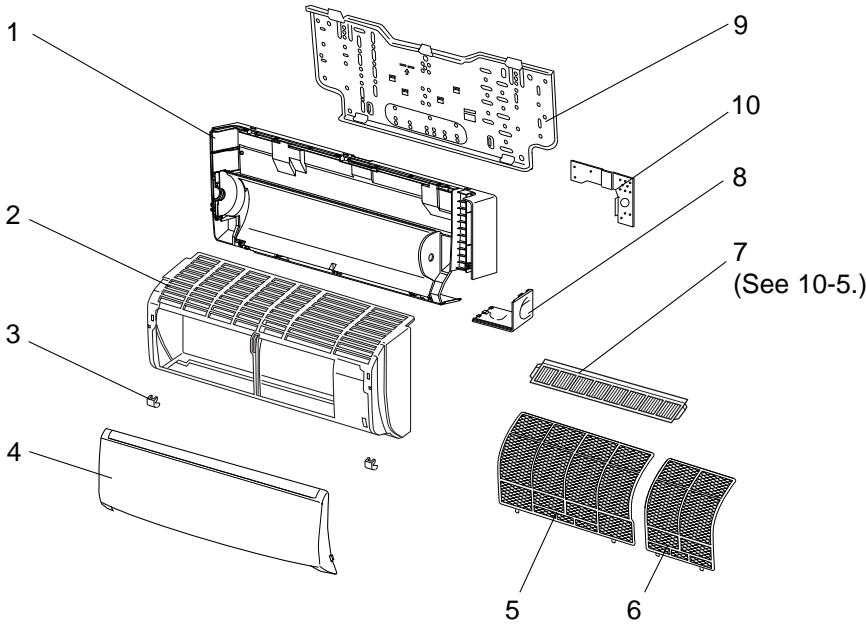

2. ACCESSORY AND REMOTE CONTROLLER

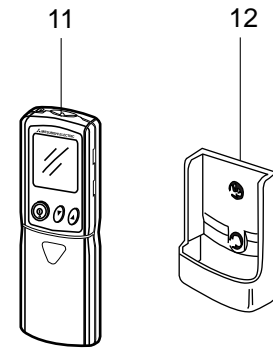

1. INDOOR UNIT STRUCTURAL PARTS

No.	Part No.	Part name	Symbol in Wiring Diagram	Q'ty/unit						Remarks
				MSZ-				MSY-		
				A09NA	A12NA	A15NA	A17NA	A15NA	A17NA	
1	E02 A32 234	BOX		1	1	1	1	1	1	
2	E02 A49 000	PANEL ASSEMBLY		1	1	1	1	1	1	Including No.3,4
3	E02 913 067	SCREW CAP		2	2	2	2	2	2	2PCS/SET
4	E02 915 010	FRONT PANEL		1	1	1	1	1	1	
5	E02 915 100	CATECHIN AIR FILTER (LEFT)		1	1	1	1	1	1	
6	E02 916 100	CATECHIN AIR FILTER (RIGHT)		1	1	1	1	1	1	
7	—	AIR CLEANING FILTER		1	1	1	1	1	1	MAC-415FT-E
8	E02 A32 975	CORNER BOX (RIGHT)		1	1	1	1	1	1	
9	E02 913 970	INSTALLATION PLATE		1	1	1	1	1	1	
10	E02 A49 978	CONDUIT PLATE		1	1	1	1	1	1	

2. ACCESSORY AND REMOTE CONTROLLER

11	E02 A54 426	REMOTE CONTROLLER		1	1	1	1			KM06A
	E02 A49 426	REMOTE CONTROLLER						1	1	KM06C
12	E02 527 083	REMOTE CONTROLLER HOLDER		1	1	1	1	1	1	

MSZ-A09NA MSZ-A12NA MSZ-A15NA MSZ-A17NA MSY-A15NA MSY-A17NA

3. INDOOR UNIT ELECTRICAL PARTS AND FUNCTIONAL PARTS

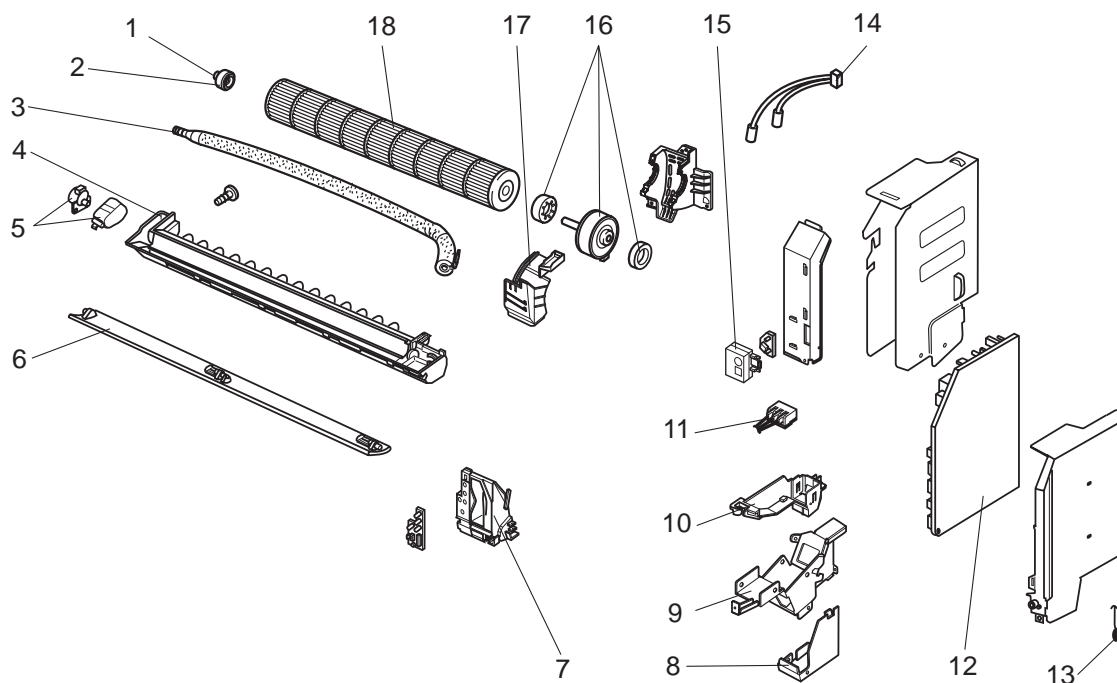

No.	Part No.	Part name	Symbol in Wiring Diagram	Q'ty/unit						Remarks
				MSZ-				MSY-		
				A09NA	A12NA	A15NA	A17NA	A15NA	A17NA	
1	E02 751 509	BEARING MOUNT		1	1	1	1	1	1	
2	E02 001 504	SLEEVE BEARING		1	1	1	1	1	1	
3	E02 897 702	DRAIN HOSE		1	1	1	1	1	1	
4	E02 A54 235	NOZZLE ASSEMBLY		1	1					
	E02 A56 235	NOZZLE ASSEMBLY				1	1	1	1	
5	E02 897 303	VANE MOTOR UNIT (HORIZONTAL)	MV	1	1	1	1	1	1	UP & DOWN
6	E02 913 040	HORIZONTAL VANE		1	1	1	1	1	1	
7	E02 913 095	POWER MONITOR RECEIVER P.C. BOARD HOLDER		1	1	1	1	1	1	
8	E02 A49 979	CONDUIT COVER		1	1	1	1	1	1	
9	E02 A49 780	TERMINAL BLOCK COVER		1	1	1	1	1	1	
10	E02 A49 779	TERMINAL BLOCK HOLDER		1	1	1	1	1	1	
11	E02 913 375	TERMINAL BLOCK	TB	1	1	1	1	1	1	
12	E02 A54 452	ELECTRONIC CONTROL P.C. BOARD *1		1						AUTO RESTART
	E02 A55 452	ELECTRONIC CONTROL P.C. BOARD *1			1					AUTO RESTART
	E02 A56 452	ELECTRONIC CONTROL P.C. BOARD *1				1				AUTO RESTART
	E02 A57 452	ELECTRONIC CONTROL P.C. BOARD *1					1			AUTO RESTART
	E02 A51 452	ELECTRONIC CONTROL P.C. BOARD *1						1		AUTO RESTART
	E02 A52 452	ELECTRONIC CONTROL P.C. BOARD *1							1	AUTO RESTART
13	E02 897 308	ROOM TEMPERATURE THERMISTOR	RT11	1	1	1	1	1	1	
14	E02 A54 307	INDOOR COIL THERMISTOR	RT12, RT13	1	1					
	E02 A56 307	INDOOR COIL THERMISTOR	RT12, RT13			1	1	1	1	
15	E02 913 782	SWITCH HOLDER		1	1	1	1	1	1	
16	E02 A54 300	INDOOR FAN MOTOR *2	MF	1	1	1	1	1	1	RC0J30- □ □
17	E02 897 333	MOTOR BAND		1	1	1	1	1	1	
18	E02 897 302	LINE FLOW FAN		1	1	1	1	1	1	

\*1 Including SW P.C. BOARD and POWER MONITOR RECEIVER P.C. BOARD

\*2 Including FAN MOTOR RUBBER MOUNT (2 PCS/SET)

MSZ-A09NA MSZ-A12NA MSZ-A15NA MSZ-A17NA MSY-A15NA MSY-A17NA

#### 4. INDOOR UNIT HEAT EXCHANGER

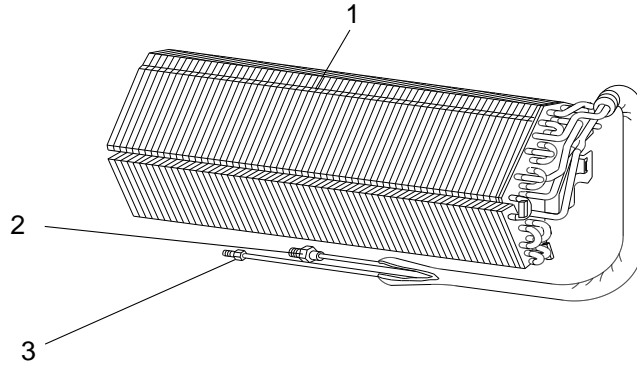

No.	Part No.	Part name	Symbol in Wiring Diagram	Q'ty/unit						Remarks
				MSZ-				MSY-		
				A09NA	A12NA	A15NA	A17NA	A15NA	A17NA	
1	E02 A54 620	INDOOR HEAT EXCHANGER		1	1					
	E02 A56 620	INDOOR HEAT EXCHANGER				1	1	1	1	
2	E02 815 666	UNION (GAS)		1	1					φ3/8
	E02 155 666	UNION (GAS)			1	1	1	1		φ1/2
3	E02 151 667	UNION (LIQUID)		1	1	1	1	1	1	φ1/4

#### 5. AIR CLEANING FILTER (ANTI-ALLERGY ENZYME FILTER)

- AIR CLEANING FILTER removes fine dust of 0.01 micron from air by means of static electricity.
- Normal life of AIR CLEANING FILTER is 1 year.  
If AIR CLEANING FILTER is to be washed, soak AIR CLEANING FILTER in water (when showing dirt, in lukewarm water) and rinse it delicately, without removing the filter from the frame about once every 3 months.
- Clogged AIR CLEANING FILTER may reduce the air conditioner capacity or cause frost on the air outlet.
- Do not remove or attach AIR CLEANING FILTER during unit operation.

Model	Part No.
MSZ-A09NA MSY-A15NA	MAC-415FT-E
MSZ-A12NA MSY-A17NA	
MSZ-A15NA MSZ-A17NA	

#### Replacement of the air cleaning filter

- (1) Remove the catechin air filter(left one)  
The air cleaning filter is not attached to the right side catechin air filter

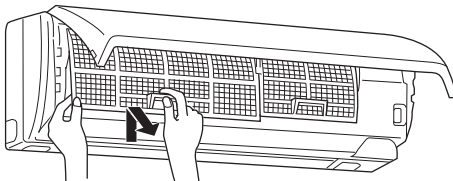

- (2) Remove the air cleaning filter(Blue bellows type) from the catechin air filter.

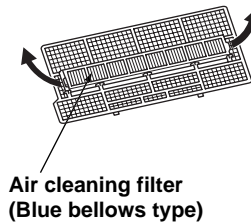

**MSZ-A24NA  
MSY-A24NA**

**6. INDOOR UNIT STRUCTURAL PARTS**

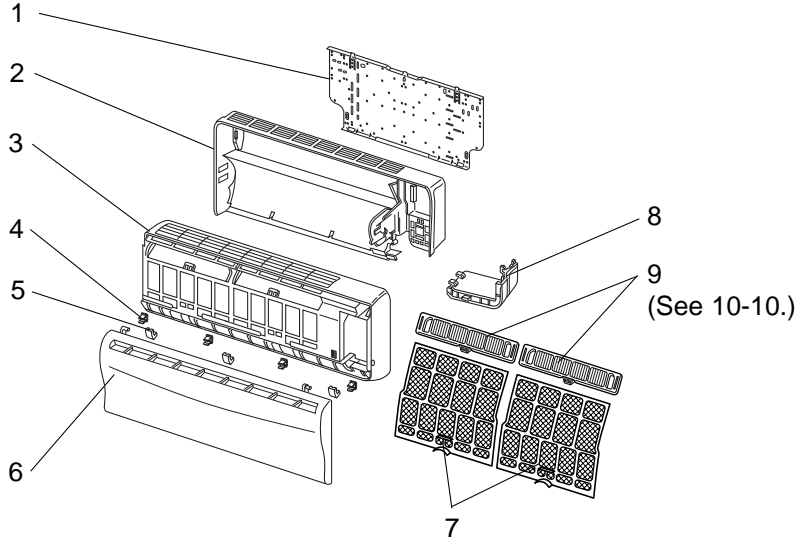

**7. INDOOR UNIT HEAT EXCHANGER**

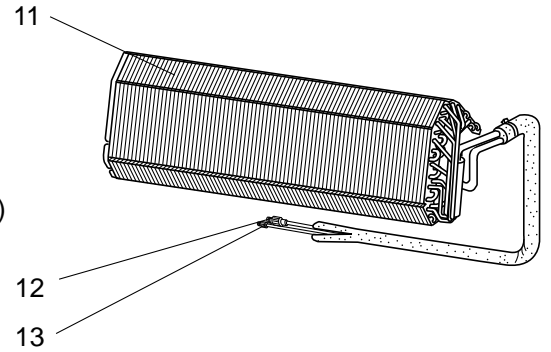

**6. INDOOR UNIT STRUCTURAL PARTS**

Part number that is circled is not shown in the illustration.

No.	Part No.	Part Name	Symbol in Wiring Diagram	Q'ty/unit		Remarks
				MSZ-A24NA	MSY-A24NA	
1	E02 527 970	INSTALLATION PLATE		1	1	
2	E02 685 234	BOX		1	1	
3	E02 888 000	FRONT PANEL ASSEMBLY		1	1	Including No.5,6
4	E02 408 142	CATCH		4	4	4PCS/ SET
5	E02 685 067	SCREW CAP		3	3	3PCS/ SET
6	E02 888 010	GRILLE		1	1	
7	E02 534 100	CATECHIN AIR FILTER		2	2	1PC/ SET
8	E02 685 975	CORNER BOX (RIGHT)		1	1	
9	—	AIR CLEANING FILTER		2	2	MAC-2300FT
⑩	E02 A36 007	LAMP PANEL		1	1	

**7. INDOOR UNIT HEAT EXCHANGER**

11	E02 A58 620	INDOOR HEAT EXCHANGER		1	1	
12	E02 527 666	UNION (GAS)		1	1	φ5/8
13	E02 151 667	UNION (LIQUID)		1	1	φ1/4

## MSZ-A24NA

## MSY-A24NA

### 8. INDOOR UNIT FUNCTIONAL PARTS AND ELECTRICAL PARTS

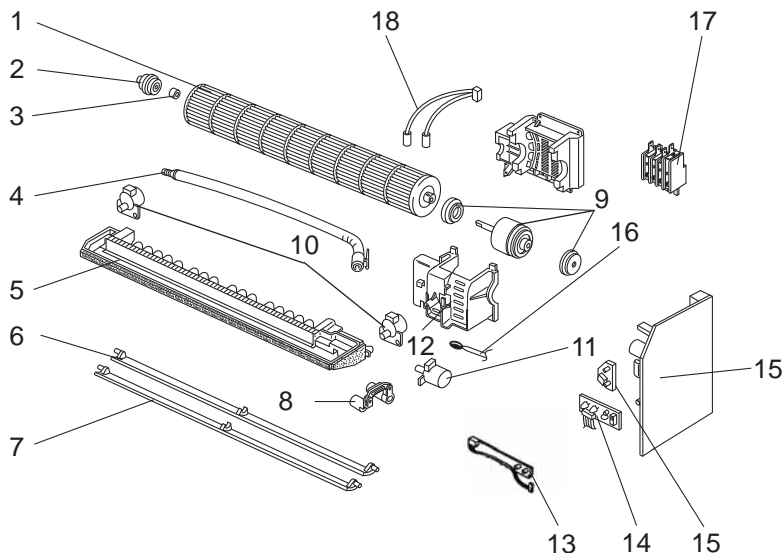

### 9. ACCESSORY AND REMOTE CONTROLLER

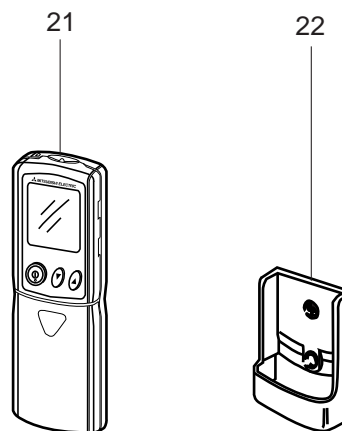

### 8. INDOOR UNIT FUNCTIONAL PARTS AND ELECTRICAL PARTS

Part numbers that are circled are not shown in the illustration.

No.	Part No.	Part Name	Symbol in Wiring Diagram	Q'ty/unit		Remarks
				MSZ-A24NA	MSY-A24NA	
1	E02 527 302	LINE FLOW FAN		1	1	
2	E02 408 509	BEARING MOUNT		1	1	
3	E02 001 504	SLEEVE BEARING		1	1	
4	E02 408 702	DRAIN HOSE		1	1	
5	E02 A58 235	NOZZLE		1	1	
6	E02 685 040	VANE UPPER		1	1	
7	E02 685 041	VANE LOWER		1	1	
8	E02 527 034	VANE CRANK SET		1	1	
9	E02 918 300	INDOOR FAN MOTOR ASSEMBLY *1	MF	1	1	RC0J56 - □□
10	E02 448 303	VANE MOTOR (VERTICAL)	MV2	2	2	RIGHT & LEFT
11	E02 408 303	VANE MOTOR (HORIZONTAL)	MV1	1	1	UP & DOWN
12	E02 918 333	MOTOR BAND		1	1	
13	E02 918 329	DISPLAY P.C. BOARD	*2	1	1	
14	E02 918 468	RECEIVER P.C. BOARD	*2	1	1	
15	E02 A58 452	ELECTRONIC CONTROL P.C. BOARD		1		AUTO RESTART
	E02 A53 452	ELECTRONIC CONTROL P.C. BOARD			1	AUTO RESTART
16	E02 527 308	ROOM TEMPERATURE THERMISTOR	RT11	1	1	
17	E02 A58 375	TERMINAL BLOCK	TB	1	1	
18	E02 918 307	INDOOR COIL THERMISTOR	RT12, RT13	1	1	
19	E02 528 034	VANE MOTOR SUPPORT SET(RIGHT)		1	1	
20	E02 529 034	VANE MOTOR SUPPORT SET(LEFT)		1	1	

\*1 Including FAN MOTOR RUBBER MOUNT

\*2 Including SW P.C. BOARD

### 9. ACCESSORY AND REMOTE CONTROLLER

21	E02 A58 426	REMOTE CONTROLLER		1		KM06B
	E02 A53 426	REMOTE CONTROLLER			1	KM06D
22	E02 527 083	REMOTE CONTROLLER HOLDER		1	1	

## 10. AIR CLEANING FILTER (ANTI-ALLERGY ENZYME FILTER)

- AIR CLEANING FILTER removes fine dust of 0.01 micron from air by means of static electricity.
- Normal life of AIR CLEANING FILTER is 1 year.  
If AIR CLEANING FILTER is to be washed, soak AIR CLEANING FILTER in water (when showing dirt, in lukewarm water) and rinse it delicately, without removing the filter from the frame about once every 3 months.
- Clogged AIR CLEANING FILTER may reduce the air conditioner capacity or cause frost on the air outlet.
- Do not remove or attach AIR CLEANING FILTER during unit operation.

Model	Part No.
MSZ-A24NA MSY-A24NA	MAC-2300FT

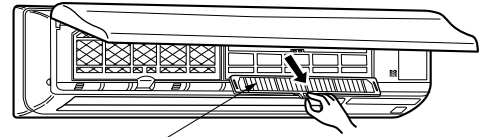

Air cleaning filter  
(Anti-allergy enzyme filter:blue bellows type)

## 10-2. RoHS PARTS LIST (RoHS compliant)

MSZ-A09NA MSY-A15NA

MSZ-A12NA MSY-A17NA

MSZ-A15NA

MSZ-A17NA

### 1. INDOOR UNIT STRUCTURAL PARTS

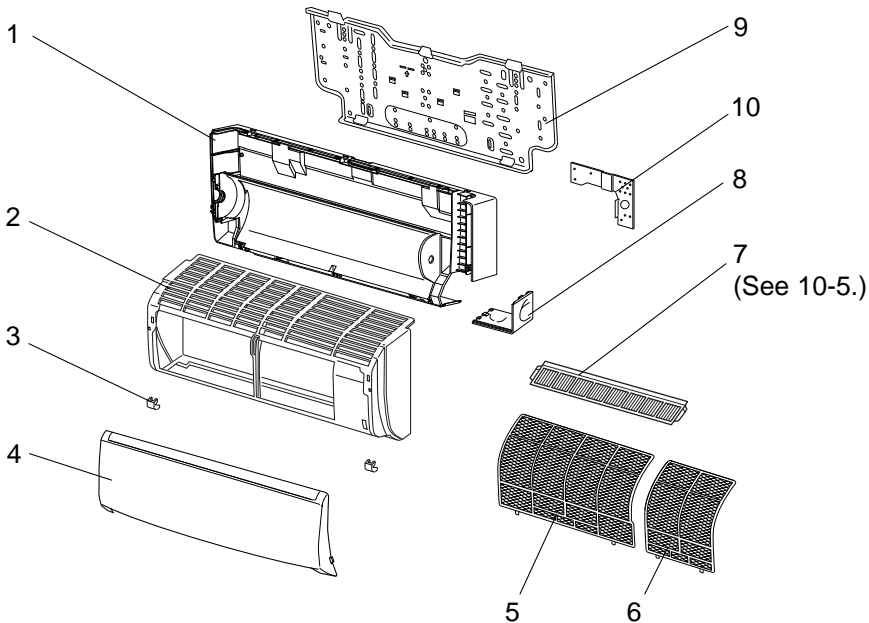

### 2. ACCESSORY AND REMOTE CONTROLLER

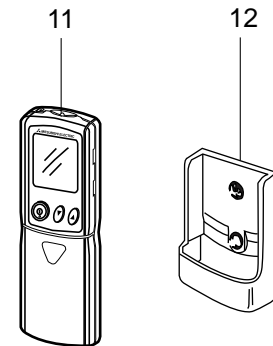

### 1. INDOOR UNIT STRUCTURAL PARTS

No.	RoHS	Part No.	Part name	Symbol in Wiring Diagram	Q'ty/unit						Remarks
					MSZ-				MSY-		
					A09NA	A12NA	A15NA	A17NA	A15NA	A17NA	
1	G	E12 A32 234	BOX		1	1	1	1	1	1	
2	G	E12 A49 000	PANEL ASSEMBLY		1	1	1	1	1	1	Including No.3,4
3	G	E12 913 067	SCREW CAP		2	2	2	2	2	2	2PCS/SET
4	G	E12 915 010	FRONT PANEL		1	1	1	1	1	1	
5	G	E12 915 100	CATECHIN AIR FILTER (LEFT)		1	1	1	1	1	1	
6	G	E12 916 100	CATECHIN AIR FILTER (RIGHT)		1	1	1	1	1	1	
7	G	—————	AIR CLEANING FILTER		1	1	1	1	1	1	MAC-415FT-E
8	G	E12 A32 975	CORNER BOX (RIGHT)		1	1	1	1	1	1	
9	G	E12 913 970	INSTALLATION PLATE		1	1	1	1	1	1	
10	G	E12 A49 978	CONDUIT PLATE		1	1	1	1	1	1	

### 2. ACCESSORY AND REMOTE CONTROLLER

11	G	E12 A54 426	REMOTE CONTROLLER		1	1	1	1			KM06A
	G	E12 A49 426	REMOTE CONTROLLER						1	1	KM06C
12	G	E12 527 083	REMOTE CONTROLLER HOLDER		1	1	1	1	1	1	

MSZ-A09NA MSZ-A12NA MSZ-A15NA MSZ-A17NA MSY-A15NA MSY-A17NA

3. INDOOR UNIT ELECTRICAL PARTS AND FUNCTIONAL PARTS

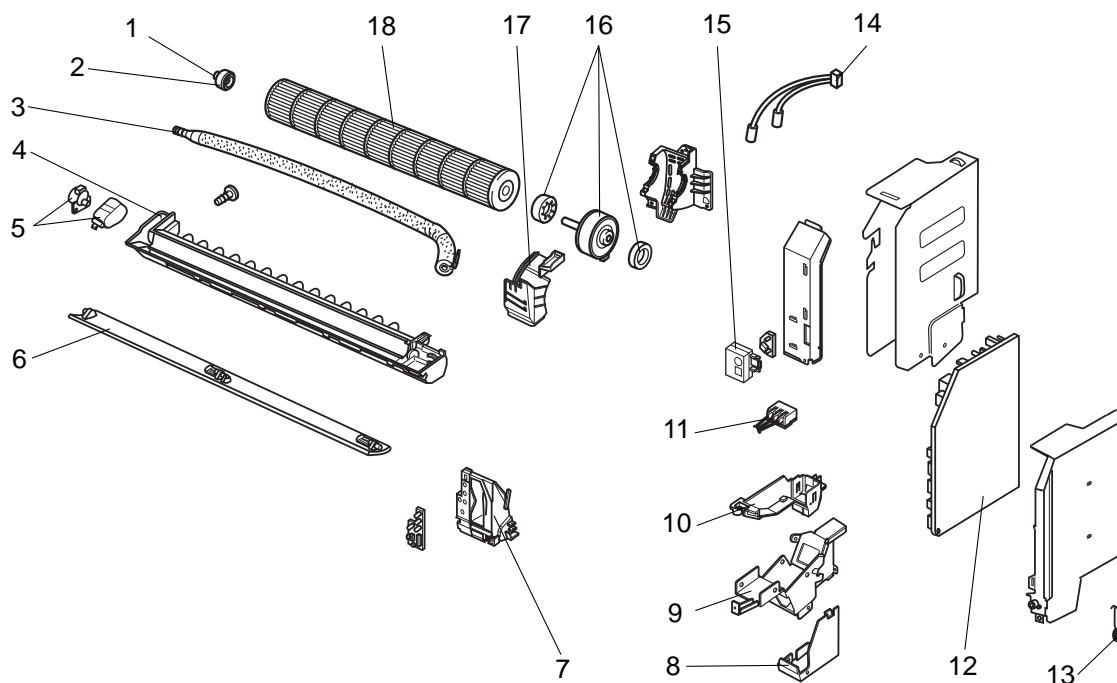

No.	RoHS	Part No.	Part name	Symbol in Wiring Diagram	Q'ty/unit						Remarks
					MSZ-				MSY-		
					A09NA	A12NA	A15NA	A17NA	A15NA	A17NA	
1	G	E12 751 509	BEARING MOUNT		1	1	1	1	1	1	
2	G	E12 001 504	SLEEVE BEARING		1	1	1	1	1	1	
3	G	E12 897 702	DRAIN HOSE		1	1	1	1	1	1	
4	G	E12 A54 235	NOZZLE ASSEMBLY		1	1					
	G	E12 A56 235	NOZZLE ASSEMBLY				1	1	1	1	
5	G	E12 897 303	VANE MOTOR UNIT (HORIZONTAL)	MV	1	1	1	1	1	1	UP & DOWN
6	G	E12 913 040	HORIZONTAL VANE		1	1	1	1	1	1	
7	G	E12 913 095	POWER MONITOR RECEIVER P.C. BOARD HOLDER		1	1	1	1	1	1	
8	G	E12 A49 979	CONDUIT COVER		1	1	1	1	1	1	
9	G	E12 A49 780	TERMINAL BLOCK COVER		1	1	1	1	1	1	
10	G	E12 A49 779	TERMINAL BLOCK HOLDER		1	1	1	1	1	1	
11	G	E12 913 375	TERMINAL BLOCK	TB	1	1	1	1	1	1	
12	G	E12 A54 452	ELECTRONIC CONTROL P.C. BOARD *1		1						AUTO RESTART
	G	E12 A55 452	ELECTRONIC CONTROL P.C. BOARD *1			1					AUTO RESTART
	G	E12 A56 452	ELECTRONIC CONTROL P.C. BOARD *1				1				AUTO RESTART
	G	E12 A57 452	ELECTRONIC CONTROL P.C. BOARD *1					1			AUTO RESTART
	G	E12 A51 452	ELECTRONIC CONTROL P.C. BOARD *1						1		AUTO RESTART
13	G	E12 A52 452	ELECTRONIC CONTROL P.C. BOARD *1							1	AUTO RESTART
14	G	E12 897 308	ROOM TEMPERATURE THERMISTOR	RT11	1	1	1	1	1	1	
	G	E12 A54 307	INDOOR COIL THERMISTOR	RT12, RT13	1	1					
15	G	E12 A56 307	INDOOR COIL THERMISTOR	RT12, RT13			1	1	1	1	
	G	E12 913 782	SWITCH HOLDER		1	1	1	1	1	1	
16	G	E12 A54 300	INDOOR FAN MOTOR *2	MF	1	1	1	1	1	1	RC0J30-□ □
17	G	E12 897 333	MOTOR BAND		1	1	1	1	1	1	
18	G	E12 897 302	LINE FLOW FAN		1	1	1	1	1	1	

\*1 Including SW P.C. BOARD and POWER MONITOR RECEIVER P.C. BOARD

\*2 Including FAN MOTOR RUBBER MOUNT (2 PCS/SET)

MSZ-A09NA MSZ-A12NA MSZ-A15NA MSZ-A17NA MSY-A15NA MSY-A17NA

#### 4. INDOOR UNIT HEAT EXCHANGER

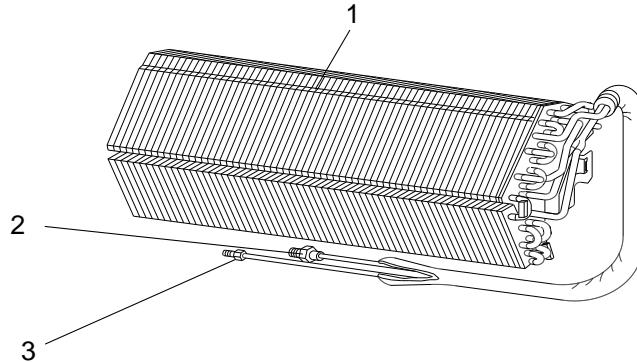

No.	ROHS	Part No.	Part name	Symbol in Wiring Diagram	Q'ty/unit						Remarks
					MSZ-				MSY-		
					A09NA	A12NA	A15NA	A17NA	A15NA	A17NA	
1	G	E12 A54 620	INDOOR HEAT EXCHANGER		1	1					
	G	E12 A56 620	INDOOR HEAT EXCHANGER				1	1	1	1	
2	G	E12 815 666	UNION (GAS)		1	1					φ3/8
	G	E12 155 666	UNION (GAS)				1	1	1	1	φ1/2
3	G	E12 151 667	UNION (LIQUID)		1	1	1	1	1	1	φ1/4

#### 5. AIR CLEANING FILTER (ANTI-ALLERGY ENZYME FILTER)

- AIR CLEANING FILTER removes fine dust of 0.01 micron from air by means of static electricity.
- Normal life of AIR CLEANING FILTER is 1 year.  
If AIR CLEANING FILTER is to be washed, soak AIR CLEANING FILTER in water (when showing dirt, in lukewarm water) and rinse it delicately, without removing the filter from the frame about once every 3 months.
- Clogged AIR CLEANING FILTER may reduce the air conditioner capacity or cause frost on the air outlet.
- Do not remove or attach AIR CLEANING FILTER during unit operation.

Model	Part No.
MSZ-A09NA MSY-A15NA	MAC-415FT-E
MSZ-A12NA MSY-A17NA	
MSZ-A15NA MSZ-A17NA	

#### Replacement of the air cleaning filter

- (1) Remove the catechin air filter(left one)  
The air cleaning filter is not attached to the right side catechin air filter

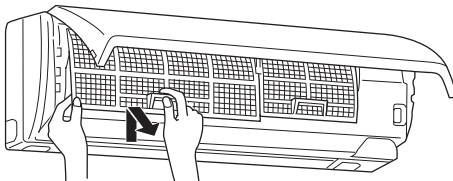

- (2) Remove the air cleaning filter(Blue bellows type) from the catechin air filter.

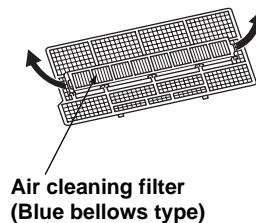

**MSZ-A24NA**

**MSY-A24NA**

**6. INDOOR UNIT STRUCTURAL PARTS**

**7. INDOOR UNIT HEAT EXCHANGER**

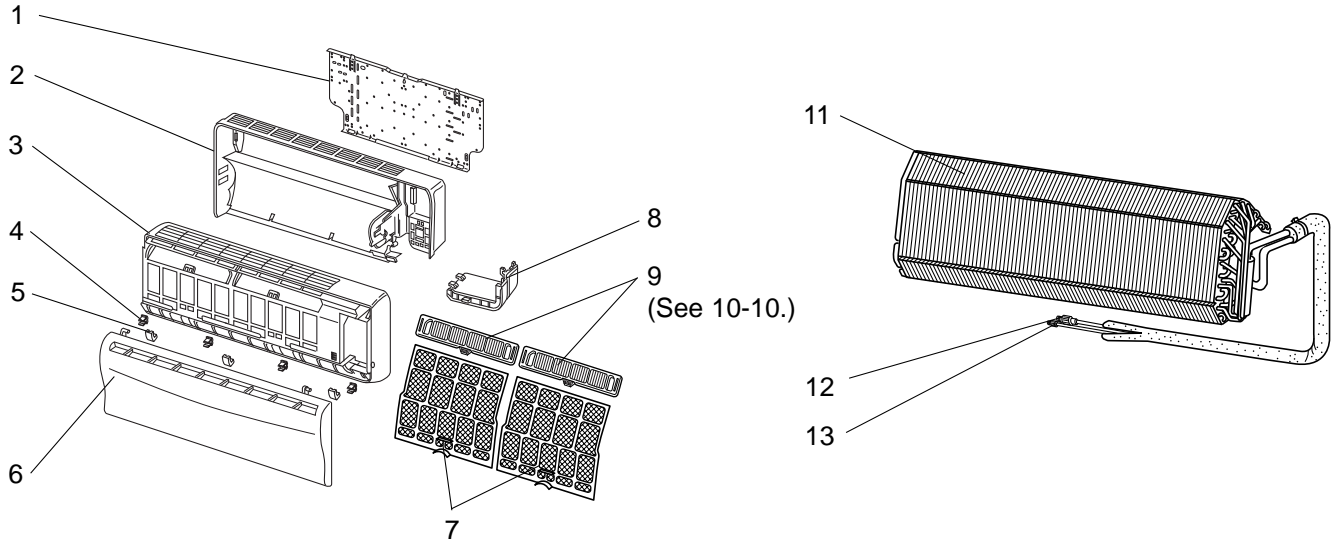

**6. INDOOR UNIT STRUCTURAL PARTS**

Part number that is circled is not shown in the illustration.

No.	RoHS	Part No.	Part Name	Symbol in Wiring Diagram	Q'ty/unit		Remarks
					MSZ-A24NA	MSY-A24NA	
1	G	E12 527 970	INSTALLATION PLATE		1	1	
2	G	E12 685 234	BOX		1	1	
3	G	E12 888 000	FRONT PANEL ASSEMBLY		1	1	Including No.5,6
4	G	E12 408 142	CATCH		4	4	4PCS/ SET
5	G	E12 685 067	SCREW CAP		3	3	3PCS/ SET
6	G	E12 888 010	GRILLE		1	1	
7	G	E12 534 100	CATECHIN AIR FILTER		2	2	1PC/ SET
8	G	E12 685 975	CORNER BOX (RIGHT)		1	1	
9	G	—	AIR CLEANING FILTER		2	2	MAC-2300FT
⑩	G	E12 A36 007	LAMP PANEL		1	1	

**7. INDOOR UNIT HEAT EXCHANGER**

11	G	E12 A58 620	INDOOR HEAT EXCHANGER		1	1	
12	G	E12 527 666	UNION (GAS)		1	1	φ5/8
13	G	E12 151 667	UNION (LIQUID)		1	1	φ1/4

**MSZ-A24NA  
MSY-A24NA**

**8. INDOOR UNIT FUNCTIONAL PARTS AND ELECTRICAL PARTS**

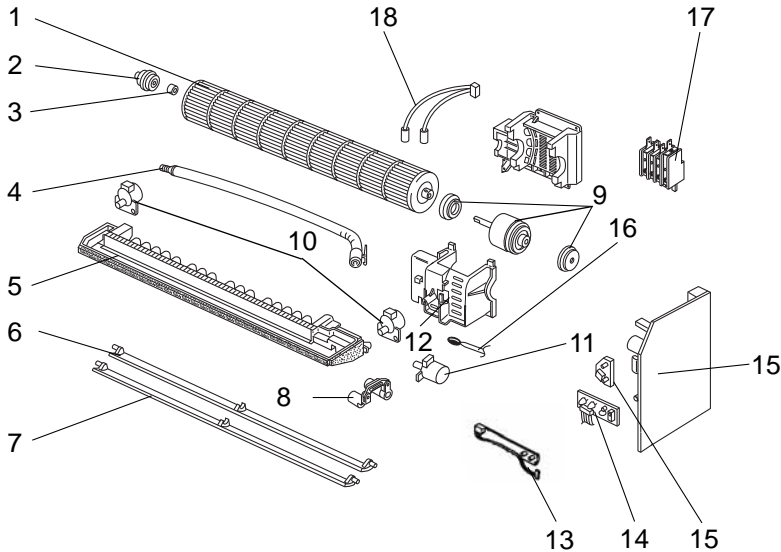

**9. ACCESSORY AND REMOTE CONTROLLER**

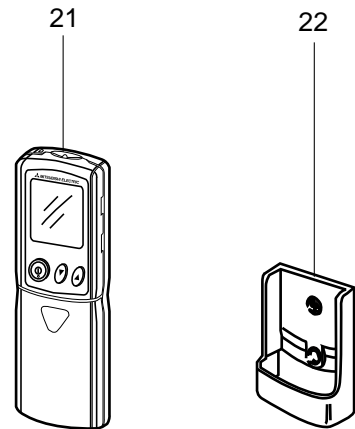

**8. INDOOR UNIT FUNCTIONAL PARTS AND ELECTRICAL PARTS**

Part numbers that are circled are not shown in the illustration.

No.	RoHS	Part No.	Part Name	Symbol in Wiring Diagram	Q'ty/unit		Remarks
					MSZ-A24NA	MSY-A24NA	
1	G	E12 527 302	LINE FLOW FAN		1	1	
2	G	E12 408 509	BEARING MOUNT		1	1	
3	G	E12 001 504	SLEEVE BEARING		1	1	
4	G	E12 408 702	DRAIN HOSE		1	1	
5	G	E12 A58 235	NOZZLE		1	1	
6	G	E12 685 040	VANE UPPER		1	1	
7	G	E12 685 041	VANE LOWER		1	1	
8	G	E12 527 034	VANE CRANK SET		1	1	
9	G	E12 918 300	INDOOR FAN MOTOR ASSEMBLY *1	MF	1	1	RC0J56 - □□
10	G	E12 448 303	VANE MOTOR (VERTICAL)	MV2	2	2	RIGHT & LEFT
11	G	E12 408 303	VANE MOTOR (HORIZONTAL)	MV1	1	1	UP & DOWN
12	G	E12 918 333	MOTOR BAND		1	1	
13	G	E12 918 329	DISPLAY P.C. BOARD		1	1	*2
14	G	E12 918 468	RECEIVER P.C. BOARD		1	1	*2
15	G	E12 A58 452	ELECTRONIC CONTROL P.C. BOARD		1		AUTO RESTART
	G	E12 A53 452	ELECTRONIC CONTROL P.C. BOARD			1	AUTO RESTART
16	G	E12 527 308	ROOM TEMPERATURE THERMISTOR	RT11	1	1	
17	G	E12 A58 375	TERMINAL BLOCK	TB	1	1	
18	G	E12 918 307	INDOOR COIL THERMISTOR	RT12, RT13	1	1	
19	G	E12 528 034	VANE MOTOR SUPPORT SET(RIGHT)		1	1	
20	G	E12 529 034	VANE MOTOR SUPPORT SET(LEFT)		1	1	

\*1 Including FAN MOTOR RUBBER MOUNT

\*2 Including SW P.C. BOARD

**9. ACCESSORY AND REMOTE CONTROLLER**

21	G	E12 A58 426	REMOTE CONTROLLER		1		KM06B
	G	E12 A53 426	REMOTE CONTROLLER			1	KM06D
22	G	E12 527 083	REMOTE CONTROLLER HOLDER		1	1	

## 10. AIR CLEANING FILTER (ANTI-ALLERGY ENZYME FILTER)

- AIR CLEANING FILTER removes fine dust of 0.01 micron from air by means of static electricity.
- Normal life of AIR CLEANING FILTER is 1 year.  
If AIR CLEANING FILTER is to be washed, soak AIR CLEANING FILTER in water (when showing dirt, in lukewarm water) and rinse it delicately, without removing the filter from the frame about once every 3 months.
- Clogged AIR CLEANING FILTER may reduce the air conditioner capacity or cause frost on the air outlet.
- Do not remove or attach AIR CLEANING FILTER during unit operation.

Model	Part No.
MSZ-A24NA MSY-A24NA	MAC-2300FT

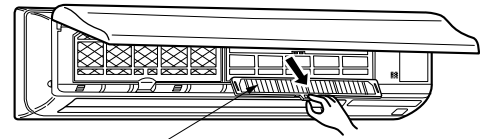

**Air cleaning filter**  
(Anti-allergy enzyme filter:blue bellows type)

MSZ-A09NA MSZ-A17NA MSY-A15NA  
 MSZ-A12NA MSZ-A24NA MSY-A17NA  
 MSZ-A15NA MSY-A24NA

## WIRELESS REMOTE CONTROLLER

\* These pictures show MSZ-A24.

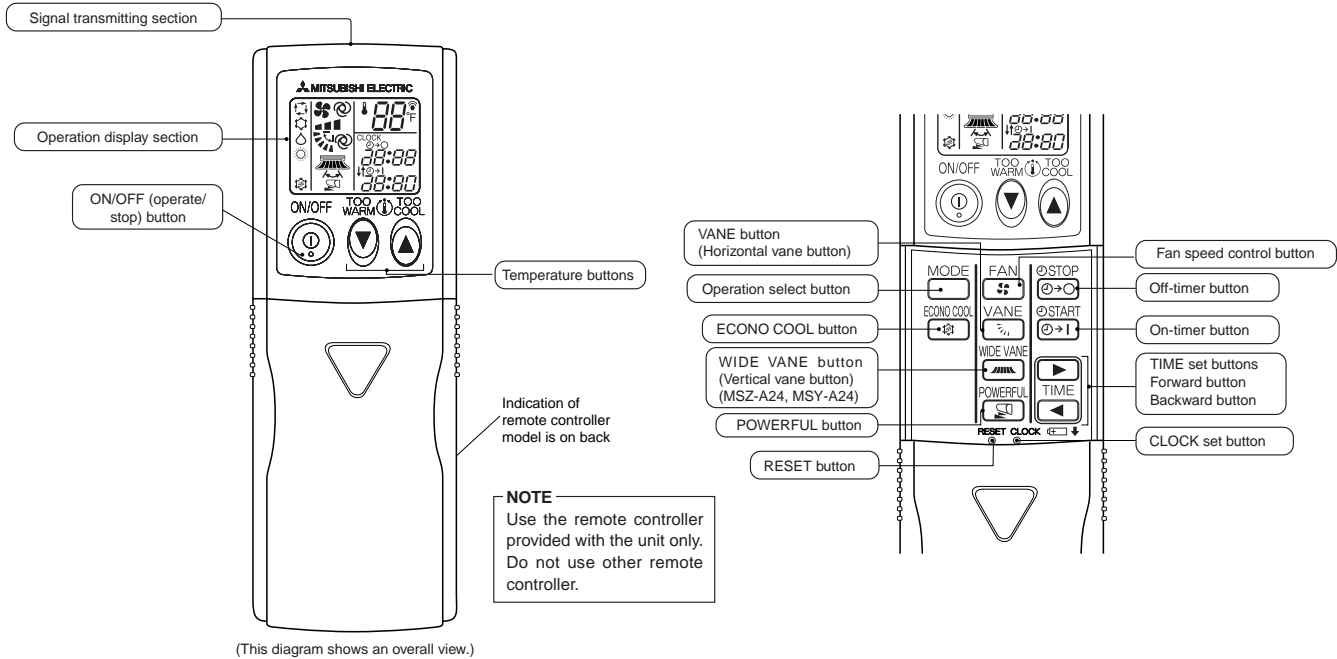

Once the operation mode is set, the same operation mode can be repeated by simply turning OPERATE/STOP (ON/OFF) button ON.

Indoor unit receives the signal with a beep tone.

When the system turns off, 3-minute time delay will operate to protect system from overload and compressor will not restart for 3 minutes.

## INDOOR UNIT DISPLAY SECTION

### Operation Indicator lamp

The operation indicator at the right side of the indoor unit indicates the operation state.

•The following indication applies regardless of shape of the indicator.

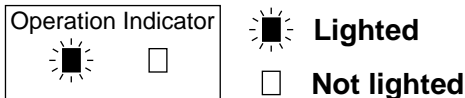

Indication	Operation state	Difference between target temperature and room temperature
	This shows that the air conditioner is operating to reach the target temperature. Please wait until the target temperature is obtained.	Approximate 4°F or more
	This shows that the room temperature is approaching the target temperature.	Approximate 4°F or less
	This shows a state of standby for operation. (For multi system air conditioner)	—

## 11-1. COOL ( ❄ ) OPERATION

- (1) Press OPERATE/STOP(ON/OFF) button.  
OPERATION INDICATOR lamp of the indoor unit turns on with a beep tone.
- (2) Select COOL mode with OPERATION SELECT button.
- (3) Press TEMPERATURE buttons (TOO WARM or TOO COOL button) to select the desired temperature.  
The setting range is 61 ~ 88°F.

### 1. Coil frost prevention

When the temperature of indoor heat exchanger becomes too low, the coil frost prevention mode works.  
The indoor fan operates at the set speed and the compressor stops. This mode continues until the temperature of indoor heat exchanger rises.

### 2. Low outside temperature operation

When the outside temperature lowers during cool mode operation, low outside temperature operation starts, and the outdoor fan slows or stops.

## 11-2. DRY ( ☀ ) OPERATION

- (1) Press OPERATE/STOP(ON/OFF) button.  
OPERATION INDICATOR lamp of the indoor unit turns on with a beep tone.
- (2) Select DRY mode with OPERATION SELECT button.
- (3) The set temperature is determined from the initial room temperature.

### 1. Coil frost prevention

Coil frost prevention is as same as COOL mode. (11-1.1.)

### 2. Low outside temperature operation

Low outside temperature operation is as same as COOL mode. (11-1.2.)

## 11-3. HEAT ( 🔥 ) OPERATION (MSZ)

- (1) Press OPERATE/STOP(ON/OFF) button.  
OPERATION INDICATOR lamp of the indoor unit turns on with a beep tone.
- (2) Select HEAT mode with OPERATION SELECT button.
- (3) Press TEMPERATURE buttons (TOO WARM or TOO COOL button) to select the desired temperature.  
The setting range is 61 ~ 88°F.

### 1. Cold air prevention control

When the compressor is not operating or is starting, and the temperature of indoor heat exchanger and/or the room temperature is low or when defrosting is being done, the indoor fan will stop or rotate in Very Low speed.

### 2. High pressure protection

In HEAT operation the compressor operational frequency is controlled by the temperature of the indoor heat exchanger to prevent the condensing pressure from increasing excessively.

### 3. Defrosting

Defrosting starts when the temperature of outdoor heat exchanger becomes too low.  
The indoor/outdoor fans stop, the 4-way valve reverses, and the compressor starts.  
This mode continues until the temperature of outdoor heat exchanger rises or the fixed time passes.

## 11-4. FAN( 🌀 ) OPERATION (MSY)

- (1) Press OPERATE/STOP(ON/OFF) button.  
OPERATION INDICATOR lamp of the indoor unit turns ON with a beep tone.
- (2) Select FAN mode with OPERATION SELECT button.
- (3) Select the desired fan speed. When AUTO, it becomes Low.  
Only indoor fan operates. Outdoor unit does not operate.

## 11-5. "I FEEL CONTROL" ( 🏠 ) OPERATION (MSY)

- (1) Press OPERATE/STOP (ON/OFF) button on the remote controller. OPERATION INDICATOR lamp of the indoor unit turns on with a beep tone.
- (2) Select "I FEEL CONTROL" mode with OPERATION SELECT button.
- (3) The operation mode is determined by the room temperature at start-up of the operation.

Initial room temperature	Mode
75°F or more	COOL mode of "I FEEL CONTROL"
less than 75°F	DRY mode of "I FEEL CONTROL"

- Once the mode is fixed, the mode does not change by room temperature afterwards.
- Under the ON-TIMER ( ⌚ ) operation, mode is determined according to the room temperature at the set time the operation starts.

(4) The initial set temperature is decided by the initial room temperature.

Model	Initial room temperature	Initial set temperature	
COOL mode of "I FEEL CONTROL"	79°F or more	75°F	※1
	77°F to 79°F	Initial room temperature minus 4°F	
DRY mode of "I FEEL CONTROL"	less than 77°F	Initial room temperature minus 4°F	

※1 When the system is restarted with the remote controller, the system operates with the previous set temperature regardless of room temperature at restart.  
The set temperature is calculated by the previous set temperature.

(5) TEMPERATURE buttons

In "I FEEL CONTROL" (  ) mode, set temperature is decided by the microprocessor based on the room temperature. In addition, set temperature can be controlled by TOO WARM or TOO COOL buttons when you feel too cool or too warm. Each time the TOO WARM or TOO COOL button is pressed, the indoor unit receives the signal and emits a beep tone.

• **Fuzzy control**

When the TOO COOL or TOO WARM button is pressed, the microprocessor changes the set temperature, considering the room temperature, the frequency of pressing TOO COOL or TOO WARM button and the user's preference to heat or cool. So this is called "Fuzzy control", and works only in "I FEEL CONTROL" mode. In DRY mode of "I FEEL CONTROL", the set temperature doesn't change.



...To raise the set temperature 2~4 degrees (°F)



...To lower the set temperature 2~4 degrees (°F)

**11-6. AUTO CHANGE OVER ... AUTO MODE OPERATION (MSZ)**

Once desired temperature is set, unit operation is switched automatically between COOL and HEAT operation.

**Mode selection**

(1) Initial mode.

When unit starts the operation with AUTO operation from off;

- If the room temperature is higher than the set temperature, operation starts in COOL mode.
- If the room temperature is equal to or lower than the set temperature, operation starts in HEAT mode.

(2) Mode change.

COOL mode changes to HEAT mode when about 15 minutes have passed with the room temperature 4 degrees below the set temperature.

HEAT mode changes to COOL mode when about 15 minutes have passed with the room temperature 4 degrees above the set temperature.

**NOTE:**

If two or more indoor units are operating in multi system, there might be a case that the indoor unit, which is operating in  (AUTO), cannot change over to the other operating mode (COOL ↔ HEAT) and becomes a state of standby. Refer to the detailed information for multi system air conditioner explained on the right.

## 11-7. AUTO VANE OPERATION

### 1. Horizontal vane

(1) Vane motor drive

These models are equipped with a stepping motor for the horizontal vane. The rotating direction, speed, and angle of the motor are controlled by pulse signals (approximate 12V) transmitted from indoor microprocessor.

(2) The horizontal vane angle and mode change as follows by pressing VANE CONTROL button.

**MSZ-A09/12/15/17**  
**MSY-A15/17**

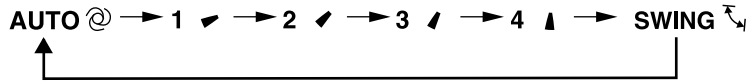

**MSZ-A24**  
**MSY-A24**

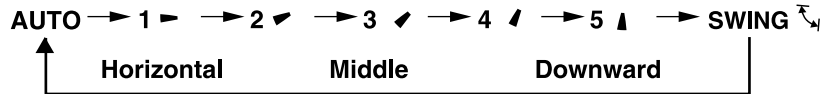

(3) Positioning

The vane is once pressed to the vane stopper to confirm the standard position and then set to the desired angle. Confirming of standard position is performed in the following cases.

- (a) When the operation starts or finishes (including timer operation).
- (b) When the test run starts.
- (c) When multi-standby starts or finishes.

(4) VANE AUTO ( @ ) mode

In VANE AUTO mode, the microprocessor automatically determines the vane angle and operation to make the optimum room-temperature distribution.

(1) In COOL and DRY operation

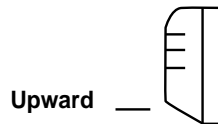

Vane angle is fixed to Horizontal position or Angle 1.

(2) In HEAT operation (MSZ)

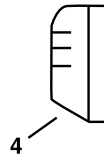

Vane angle is fixed to Angle 4.

(5) STOP (operation OFF) and ON-TIMER standby

In the following cases, the horizontal vane returns to the closed position.

- (a) When OPERATE/STOP (ON/OFF) button is pressed (POWER OFF).
- (b) When the operation is stopped by the emergency operation.
- (c) When ON-TIMER is ON standby.

(6) Dew prevention

During COOL or DRY operation with the vane angle at Angle 2 ~ 4 (A09 ~ 17) / Angle 3 ~ 5 (A24) when the compressor cumulative operation time exceeds 1 hour, the vane angle automatically changes to Angle 1 for dew prevention.

(7) SWING MODE ( ㄥ )

By selecting SWING mode with VANE CONTROL button, the horizontal vane swings vertically. The remote controller displays “ ㄥ ”.

(8) Cold air prevention in HEAT operation. (MSZ)

The horizontal vane position is set to Upward.

**NOTE:** When 2 or more indoor units are operated with multi outdoor unit, even if any indoor unit turns thermostat off, this control doesn't work in the indoor unit.

(9) To change the air flow direction not to blow directly onto your body. (MSZ-A09/12/15/17, MSY-A15/17)

To change the air flow direction	When to use this function?	COOL/DRY	HEAT (for MSZ)
Pressing and holding VANE CONTROL button for 2 seconds or more causes the horizontal vane to reverse and move to horizontal position.  Horizontal position	Use this function if you don't want the air from the indoor unit to blow directly onto your body. <ul style="list-style-type: none"> <li>Depending on the shape of the room, the air may blow directly onto your body.</li> <li>Press VANE CONTROL button again to return the vane to the previously-set position.</li> </ul>	The air conditioner starts the cooling or drying operation approx. 3 minutes after the vane has moved to the horizontal position. <ul style="list-style-type: none"> <li>When VANE CONTROL button is pressed again, the vane returns to the previously-set position and the air conditioner starts the cooling or drying operation in approx. 3 minutes.</li> </ul>	The air conditioner starts heating operation approx. 3 minutes after the vane has moved to the horizontal position. <ul style="list-style-type: none"> <li>Sometimes the area around your feet may not warm. To warm the area around the feet, set the horizontal vane to (AUTO) or the downward-blowing position.</li> <li>When VANE CONTROL button is pressed again, the vane returns to the previously-set position and the air conditioner starts the heating operation in approx. 3 minutes.</li> </ul>

**NOTE:**

- If you make the air flow not to blow directly onto your body by pressing VANE CONTROL button, the compressor stops for 3 minutes even during the operation of the air conditioner.
- The air conditioner operates with Very Low speed until the compressor turns on again.

(10) ECONO COOL ( ) operation (ECONOmical operation)

When ECONO COOL button is pressed in COOL mode, set temperature is automatically set 3.6°F higher than that in COOL mode.

Also the horizontal vane swings in various cycle.

SWING operation makes you feel cooler than set temperature. So, even though the set temperature is higher than that in COOL mode, the air conditioner can keep comfort. As a result, energy can be saved.

ECONO COOL operation is cancelled when ECONO COOL button is pressed once again or VANE CONTROL button is pressed or change to other operation mode.

(11) POWERFUL ( ) operation

The air conditioner automatically adjusts the fan speed and the set temperature, and operates the POWERFUL mode. The POWERFUL mode is automatically released 15 minutes after operation starts, and the operation mode returns to the mode prior to POWERFUL operation.

**2. Vertical vane (MSZ-A24, MSY-A24)**

(1) Vane motor drive

These models are equipped with a stepping motor for the vertical vane. The rotating direction, speed, and angle of the motor are controlled by pulse signals (approximate 12V) transmitted from microprocessor.

(2) The vertical vane angle and mode change as follows by pressing WIDE VANE button.

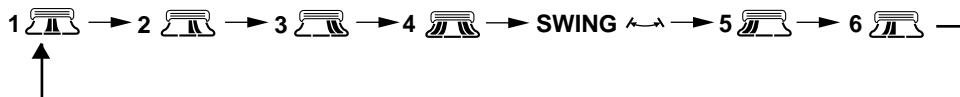

(3) Positioning

The vane is once pressed to the vane stopper to confirm the standard position and then set to the desired angle. Confirming of standard position is performed in the following cases.

- When OPERATE/STOP(ON/OFF) button is pressed (POWER ON/OFF).
- When SWING is started or finished.
- When the power supply turns ON.

(4) SWING MODE ( )



By selecting SWING mode with WIDE VANE button, the vertical vane swings horizontally.

The remote controller displays "↔".

(5) WIDE MODE (  )

By selecting WIDE mode with WIDE VANE button, indoor fan speed becomes faster than setting fan speed on the remote controller (\*). The remote controller displays “  ”.

**NOTE :** The position of vane angle 3, angle 4 and angle 5 are different in COOL operation and HEAT operation.

\* Indoor fan speed becomes faster than setting fan speed on the remote controller even when  or  is selected.

## 11-8. TIMER OPERATION

### 1. How to set the time

(1) Press OPERATE/STOP (ON/OFF) button to start the air conditioner.



(2) Check that the current time is set correctly.

**NOTE :** Timer operation will not work without setting the current time. Initially “AM0:00” blinks at the current time display of TIME MONITOR, so set the current time correctly with CLOCK SET button.

#### How to set the current time

(1) Press the CLOCK set button.

(2) Press the TIME SET buttons (  and  ) to set the current time.

- Each time FORWARD button (  ) is press, the set time increases by 1minute, and each time BACKWARD button (  ) is press, the set time decreases by 1minute.
- Pressing thoes buttons longer increases / decreases the set time by 10 minutes. Press the CLOCK set button.

#### ON timer setting



(1) Press ON-TIMER button (  ) during operation.

(2) Set the time of the timer using TIME SET buttons (  and  ). \*

#### OFF timer setting

(1) Press OFF-TIMER button (  ) during operation.

(2) Set the time of the timer using TIME SET buttons (  and  ). \*

- \* Each time FORWARD button (  ) is pressed, the set time increases by 10 minutes; each time BACKWARD button (  ) is pressed, the set time decreases by 10 minutes.

### 2. Cancel

To cancel ON timer, press ON-TIMER button (  ).

To cancel OFF timer, press OFF-TIMER button (  ).

TIMER is cancelled and the display of set time disappears.

## PROGRAM TIMER

- OFF timer and ON timer can be used in combination. The timer of the set time that is reached first will operate first.
- “ ↑ ” and “ ↓ ” display shows the order of OFF timer and ON timer operation.

(Example 1) The current time is 8:00 PM.

The unit turns off at 11:00 PM, and on at 6:00 AM.

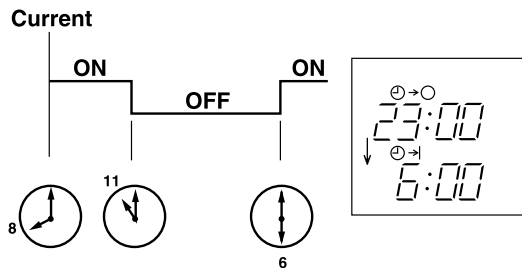

(Example 2) The current time is 11:00 AM.

The unit turns on at 5:00 PM, and off at 9:00 PM.

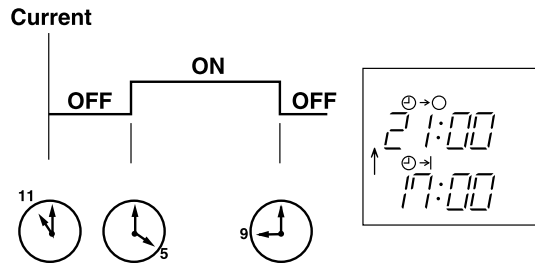

**NOTE :** If the main power is turned off or a power failure occurs while AUTO START/STOP timer is active, the timer setting is cancelled. As these models are equipped with an auto restart function, the air conditioner starts operating with timer cancelled when power is restored.

## 11-9. EMERGENCY/TEST OPERATION

In case of test run operation or emergency operation, use EMERGENCY OPERATION switch on the front of the indoor unit. Emergency operation is available when the remote controller is missing, has failed or the batteries of the remote controller run down. The unit will start and OPERATION INDICATOR lamp will light.

The first 30 minutes of operation is the test run operation. This operation is for servicing. The Indoor fan speed runs at High speed and the system is in continuous operation (with thermostat ON).

After 30 minutes of test run operation the system shifts to EMERGENCY COOL / HEAT MODE with a set temperature of 75°F. The fan speed shifts to Med..

All protective operations such as the coil frost prevention works even in emergency operation.

In the test run or emergency operation, the horizontal vane operates in VANE AUTO ( @ ) mode.

Emergency operation continues until EMERGENCY OPERATION switch is pressed once or twice or the unit receives any signal from the remote controller. In case of latter normal operation will start.

**NOTE :** Do not press EMERGENCY OPERATION switch during normal operation.

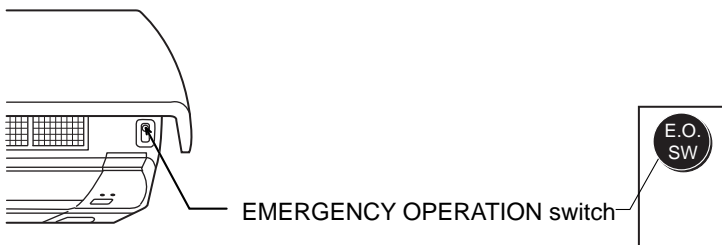

Operation mode	COOL	HEAT (MSZ)
Set temperature	75°F	75°F
Fan speed	Medium	Medium
Horizontal vane	Auto	Auto

The operation mode is indicated by the Operation Indicator lamp on the indoor unit as following

### Operation indicator lamp

#### (MSZ type)

Press once <Cool>



Lighted

Press again <Heat>



Not lighted

Press once again <Stop>



#### (MSY type)

Press once <Cool>



Press again <Stop>



 **MITSUBISHI ELECTRIC CORPORATION**



**MITSUBISHI ELECTRIC**  
HVAC Advanced Products Division

---

3400 Lawrenceville Suwanee Road • Suwanee, Georgia 30024  
Toll Free: 800-433-4822 • Toll Free Fax: 800-889-9904  
[www.mrslim.com](http://www.mrslim.com)

**Specifications are subject to change without notice.**