

# P300 PROFESSIONAL POWER AMPLIFIER

## SERVICE MANUAL *Schematic Diagrams*



CODE : 277318



<i>Technical Specifications, Test Procedures &amp; Adjustments</i>	2
<i>Wiring Connections</i>	4
<i>Inputs &amp; Protections, Power Supply and Display Boards</i>	5
<i>Power Amplifier Board</i>	6
<i>Part List, Layout</i>	7

GENERALMUSIC S.p.A. Sales Division: 47842 S.Giovanni in Marignano (RN) ITALY - Via delle Rose, 12 - tel. 0541/959511 - tlx 550555 GMUSIC I - fax 0541/957404



### Notice

Service must be carried out by qualified personnel only. Any tampering carried out by unqualified personnel during the guarantee period will forfeit the right to guarantee.

For a correct operation of the instrument, after having switched off, be careful to wait at least 3 seconds before switching on again. To improve the device's specifications, the schematic diagrams may be subject to change without prior notice.

### Schematic Notes

△ All components marked by this symbol have special safety characteristics, when replacing any of these components use only manufacturer's specified parts.

The (μ) micro symbol of capacitance value is substituted by U. The (Ω) omega symbol of resistance value is substituted by E. The electrolytic capacitors are 25Vdc rated voltage unless otherwise specified. All resistors are 1/4W unless otherwise specified.

← Soldering point.

• Male connector.

⊖ Female connector.

⊚ M/F faston connector.

□ Test point.

⊔ Flag joined with one or more flags with the same signal name inscribed.

↑ Supply voltage.

⊥ Logic supply ground.

⊓ Analog supply ground.

↓ Signal ground.

⊚ Chassis ground.



### ATTENTION

Observe precautions when handling electrostatic sensitive devices

## TECHNICAL SPECIFICATIONS

Dimensions:	(WxHxD)	483x44x310mm (1U)
Weight:		8Kg
Power Requirements:	(230Vac±10% 50Hz)	300VA
Output Power:	(8Ω stereo/parallel)	2x 150Watts
Max. Undistorted Out:	(8Ω stereo/parallel)	98Vpp
Input Sensitivity:	(constant sensitivity)	0.775Vrms (0dB)
	(constant gain)	1.75Vrms (+7dB)
Input Impedance:	(balanced)	30KΩ
	(unbalanced)	15KΩ
Voltage Gain:	(constant sensitivity)	33±0.5dB
	(constant gain)	26±0.5dB
Slew Rate:		25V/μS
Damping Factor:	(8Ω stereo/parallel)	>400
Frequency Response	(-0.2dB)	20Hz÷20KHz
at Full Power:	(-3dB)	10Hz÷60KHz
IMD:	(SMPTE 60Hz/7KHz 4:1)	<0.1%
THD:	(THD+N)	<0.1%
S/N Ratio:	(unweighted)	>95dB
Crosstalk:	(1KHz)	>70dB

## TEST PROCEDURES & ADJUSTMENTS

### Precaution

- ⊘ To prevent short circuit during any test, **the oscilloscope must be EARTH insulated**, this occurs because some test require to connect its probe to the amplifier output, non-compliance may cause damages to oscilloscope inputs circuitry.
- ⊘ Before removing or installing any modules and connectors, **disconnect the amplifier from AC MAINS** and measure the DC supply voltages across each of the power supply capacitors. If your measurement on any of the caps is greater than 10Vdc, connect a 100Ω 10W resistor across the applicable caps to discharge them for your safety. Remember to remove the discharge resistor immediately after discharging caps. **Do not power up the amplifier with the discharge resistor connected.**
- ⊘ Read these notes entirely before proceeding to any operation. These notes are not comprehensive of all damages that possibly occur, but includes some specifically advices, checks and adjustments relative to this amplifier.

### Remarks

- ⊘ The power supply utilizes a dual bipolar DC rail configuration with low and high voltages; one positive and one negative low rail (+/-Vcc1) and one positive and one negative high rail (+/-Vcc2).

### Visual Check

- ⊘ Use compressed air to clear dust in the amplifier chassis.

- ⊘ Before proceed to supply the amplifier check visually the internal assembly, if appears an evident damage find the most possible reasons that cause it.
- ⊘ Check the wiring cables for possible interruptions or shorts.
- ⊘ If the damage has burnt a printed circuit board don't try to repair it, replace with a new one.

## Test Instruments

- ⊘ Audio Generator
- ⊘ Dual Trace Oscilloscope
- ⊘ Digital Multimeter
- ⊘ 4Ω 500W, 8Ω 300W, 100Ω 10W resistors
- ⊘ Variac (0÷250Vac)

## Setup

- ⊘ Connect the Variac between the mains and the amplifier and set it at zero voltage.
- ⊘ Set the amplifier in STEREO MODE and turn full clockwise the LEVEL potentiometers.
- ⊘ Connect the audio generator to the channel inputs and set it to 1KHz 775mV<sub>RMS</sub> (0dB) sinusoidal signal.
- ⊘ The procedures that follow must be executed subsequently in the order specified.

## Supply Check

- ⊘ Remove the transformer secondary fuses (located on SUPPLY & PROTECTIONS board), set the Variac to the nominal mains voltage, check with the Multimeter the AC supply voltages:  
F1-F2=52±1.5Vac  
F3-F4=88±3Vac.
- ⊘ Re-set the Variac at zero voltage, turn off the amplifier and put the fuses back on its holders.
- ⊘ Connect the oscilloscope probes CH1/2 to the channel outputs, before RL1, set both to 20V/div. 200μS/div.
- ⊘ Set up the Variac slowly monitoring the Outputs with the oscilloscope CH1/2 connected, it should display the sinusoidal input signal amplified with no distortions, if a distortion occur check the POWER AMPLIFIER boards as suggested in the ADVICES section.
- ⊘ If the protection trips, turn off the amplifier, wait some minutes and disconnect the supplies from the outputs modules (CN1, CN4 on POWER AMPLIFIER boards), continue to check the supplies.
- ⊘ **CAUTION: Before re-connecting the output modules to the supplies, you must have the capacitors discharged for your safety: connect a 100Ω 10W resistor across the caps and remove the resistor just after they are discharged.**
- ⊘ Finally verify the DC supplies on POWER SUPPLIES board:
 

CN1 pin 1-2 (+Vcc2)	=+61±2Vdc
CN1 pin 3-4 (+Vcc1)	=+36±1.5Vdc
CN2 pin 1-2 (-Vcc1)	=-36±1.5Vdc
CN2 pin 3-4 (-Vcc2)	=-61±2Vdc
CN3 pin 3-4-5	=+15±1Vdc

CN3 pin 7-9-10 =-15±1Vdc

- ⊘ If one or more voltages don't correspond, check the rectifiers, capacitors and transformers disconnecting them from circuitry, refer to schematics.

## Channels Check

- ⊘ The channel A is on the right and channel B is on the left of the chassis.
- ⊘ These procedures are intended for one channel at a time, repeat these operation for the other channel.
- ⊘ Verify, with the Multimeter, the insulation between the heatsink and the transistors collectors.
- ⊘ Verify, with the Multimeter, the PTC resistor value (R33 connected across pin 8 an pin 9 of CN3), it must be between 50Ω and 200Ω.
- ⊘ **SETUP:**  
Connect the CH1 scope GND clip to CN2 pin 1 (GND terminal).  
Connect the CH1 probe tip to CN2 pin 2 (AMP output).  
Connect the CH2 probe tip to D9 anode and set it sensitivity at 5V/div.  
Set the LEVEL potentiometers full clockwise.  
The load resistor is disconnected.
- ⊘ **INITIAL TEST:**  
Increase slowly the Variac. The channel output signals must be symmetrical respect the GND without visible distortion and oscillation as shown in Fig.1 Trace A (Trace B shown the amplifier 2nd stage input). If there is a distortion read the section ADVICES and proceed to check the other channel.

Fig. 1

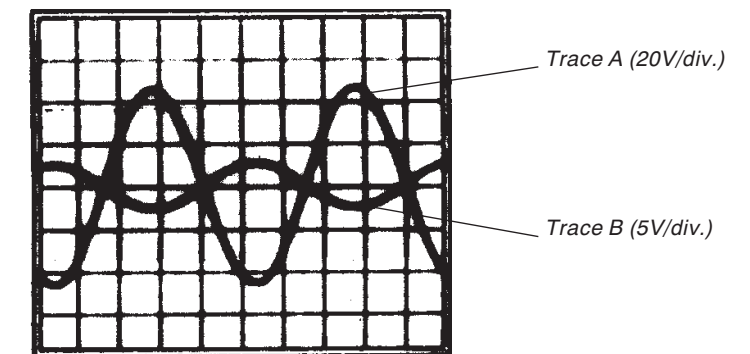

- ⊘ **BIAS ADJUSTMENT:**  
Set the generator level at zero, connect the Multimeter across the emitter and collector of TR8, then adjust R32 trimmer to read 2.5Vdc.  
Set the CH2 scope sensitivity at 0.1V/div. and adjust the R35 trimmer to set the CH2 trace at the centre of the scope screen.
- ⊘ **HIGH RAIL CHECK:**  
Connect the CH2 probe tip to D3 cathode and set it sensitivity at 20V/div. When the output signal (Positive half-wave) is less than 30Vp the voltage on D3 cathode must remain constant at 36V, when the output signal exceeds 30Vp the voltage must follow the output signal with 6V offset (see Fig.2 Trace B), to check the negative high rail connect the probe to D14 anode (see Fig.2 Trace C).  
Connect the 8Ω 300W load on the output and repeat the INITIAL and HIGH RAIL checks.  
Check the signal clipping, it must occur at 48±2Vpp (see Fig.3 Trace A,B,C).
- ⊘ **SIGNAL/CLIP SENSOR CHECK:**  
Set the LEVEL pot to minimum, set the scope timebase at 1V/div. 200μS/div., then increase the level and check the SIGNAL/CLIP led activity: it must turn on (green light) when the amplifier output is higher than 1Vp. Set the scope at 20V/div. and increase the level, check the led: it must

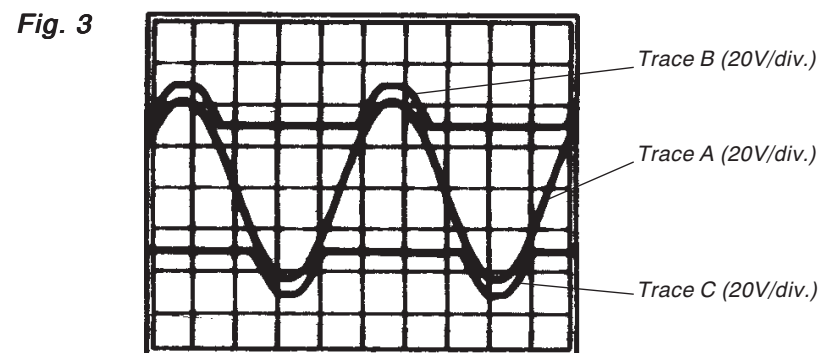
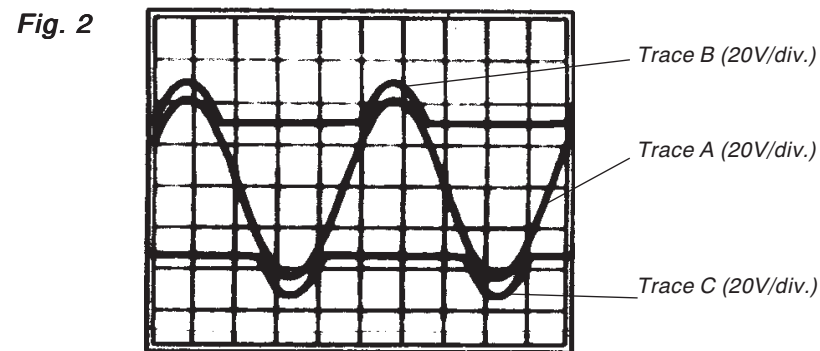

change from green to red colour at the amplifier output signal clipping.

➤ **CURRENT AND SHORT CIRCUIT SENSOR CHECK:**

Set both the scope channels sensitivity to 0.5V/div., connect the scope CH1 GND clip at CN3 pin 2 (AMP output) and the probe tip at TR6 (NPN) emitter, connect the CH2 probe tip at TR13 (PNP) emitter.

Set the generator to have approx. 1Vp on the emitters: their difference must be less than 0.2V on the peaks (see Fig.4 Trace A & B).

Connect a 4Ω 500W load. Increase the input signal, the output current

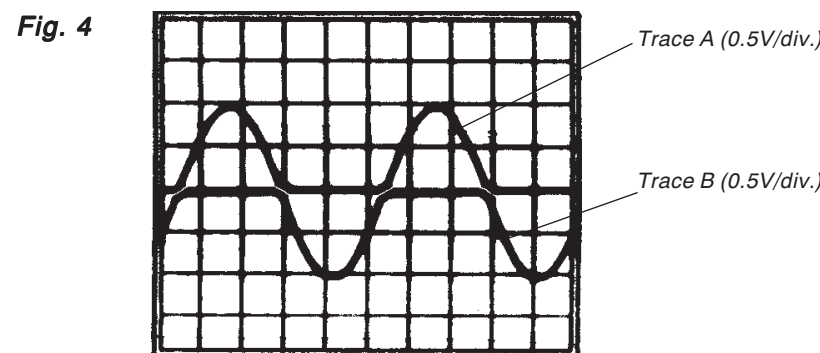

limiter must keep the emitter voltages, both half channel, at 1.5Vp approx. (see Fig.5 Trace A).

Temporarily short the amplifier output: the current limiter must keep the emitter voltages (both half channel) at 1 approx. (see Fig.5 Trace B).

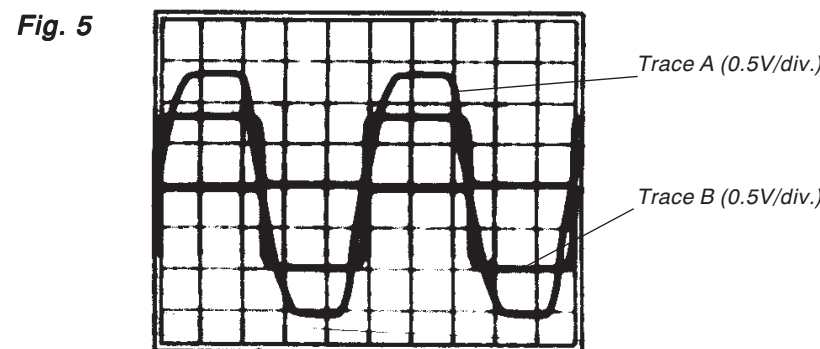

➤ **OFFSET SENSOR CHECK:**

Set the Variac to zero voltage output, disconnect the amplifier load and the supply connection to the Power board (CN1,2,4), turn on the ampli-

fier, connect temporarily (by means of a suitable conductor wire) CN2 pin 2 to +15Vdc (CN3 pin 5), the PROTECT led must turn on in 5 seconds approx.

Remove the connection, wait until the leds turn off and after some seconds repeat the check with -15Vdc (available on CN3 pin 3), the led PROTECT must turn on again.

➤ **BIAS CHECK:**

Disconnect CH2 probe. Connect the CH1 scope GND clip to CN2 pin 1 (GND terminal) and its probe tip to CN2 pin 2 (AMP output). Adjust the generator level until the sinewave appears at full screen amplitude, no crossover distortion must be detectable: if necessary re-adjust R32.

➤ **BANDWIDTH CHECK:**

Set CH1 scope sensitivity at 20V/div., increase the generator level to have 80Vpp, sweep the generator frequency from 20Hz to 20KHz: the output level must have not detectable level changes.

➤ **SLEW RATE CHECK:**

Set the scope sensitivity to 10V/div. 1μS/div. and set the generator to 1KHz square wave mode. Check the output square wave rising and falling

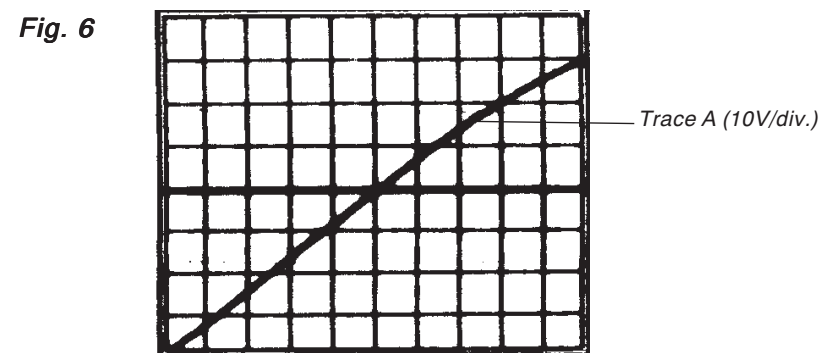

edge slopes: both must be 10V/μS or more as shown in Fig 6.

### Inputs & Protections Board Check

➤ These procedures are intended for one channel at a time, repeat these operations for the other channel.

➤ **SETUP:**

Connect the CH1 probe to amplifier input of the channel under test and set both at 500mV/div. 200mS/div.

Connect the CH2 probe to amplifier output of the channel under test and set it at 10mV/div. 200mS/div.

Set the audio generator at 1KHz sinus. 775mV<sub>RMS</sub> (0dB).

Set the LEVEL potentiometers full clockwise.

The load resistor is disconnected.

➤ **CMRR ADJUSTMENT**

Temporarily disconnect pin 3 from pin 1 and short the pin 2 (positive input) and pin 3 (negative input) of XLR input socket.

Adjust the trimmer R6 (channel A) or R19 (channel B) to obtain the minimum output level.

➤ **GAIN ADJUSTMENT**

Re-set the input signal at pin 2 (positive input) and pin 3 (negative input) short with pin 1 (GND) of XLR input socket.

Set CH2 scope at 500mV/div. and connect it to the output of INPUTS & PROTECTIONS board (CN4 pin 10 for channel A or CN4 pin 12 for channel B).

Set the input SENSITIVITY (SW1) at 1.75Vrms, adjust the trimmer R9 (channel. A) or R17 (channel B) to obtain the same amplitude of the scope signals.

➤ **AMPLIFIER GAIN CHECK**

Set CH2 scope at 20V/div. and connect it to the amplifier output of the channel under test. By means of the SENSITIVITY switch check the output levels: at 775mV position the output voltage must be 50±1.5Vp and at 1.75V position must be 22.5±0.5Vp.

➤ **SIGNAL TO NOISE RATIO CHECK**

Disconnect the audio generator and short the input (pin 1,2,3 of XLR socket shorted) the output signal (noise) must be less 1mV.

### Advices

➤ Check the channels one at time to determine which is right (note: if you have a spare amplifier module that you know as right, use it).

➤ If you have determinate that the problem is a short on a rail, you must check the output transistors.

To determine which transistor devices are bad, use a soldering iron to lift one leg of each emitter pin and measure the emitter-collector resistance on each device. Unsolder and lift one leg of each base pin and check the base-collector resistance of each transistor and replace any that measure as a short.

If all the transistors are OK, unsolder and lift one leg of each diode and check them.

Check the circuit board for open foil traces.

Use the Multimeter as Ohm-meter to check the resistors, particularly the base and emitter resistors of damaged transistor.

➤ If the input sinewave appears to be distorted during the negative cycle, you can assume that the problem is located somewhere in the circuitry of the positive low rail.

If the positive cycle appears distorted, you can assume that the problem is in the circuitry of the negative low rail.

➤ If the high rails appear distorted or are not modulating as shown in figure, then the problem probably exists somewhere in the circuitry of the respective (+ or -) defective high rail. Refer to the schematics.

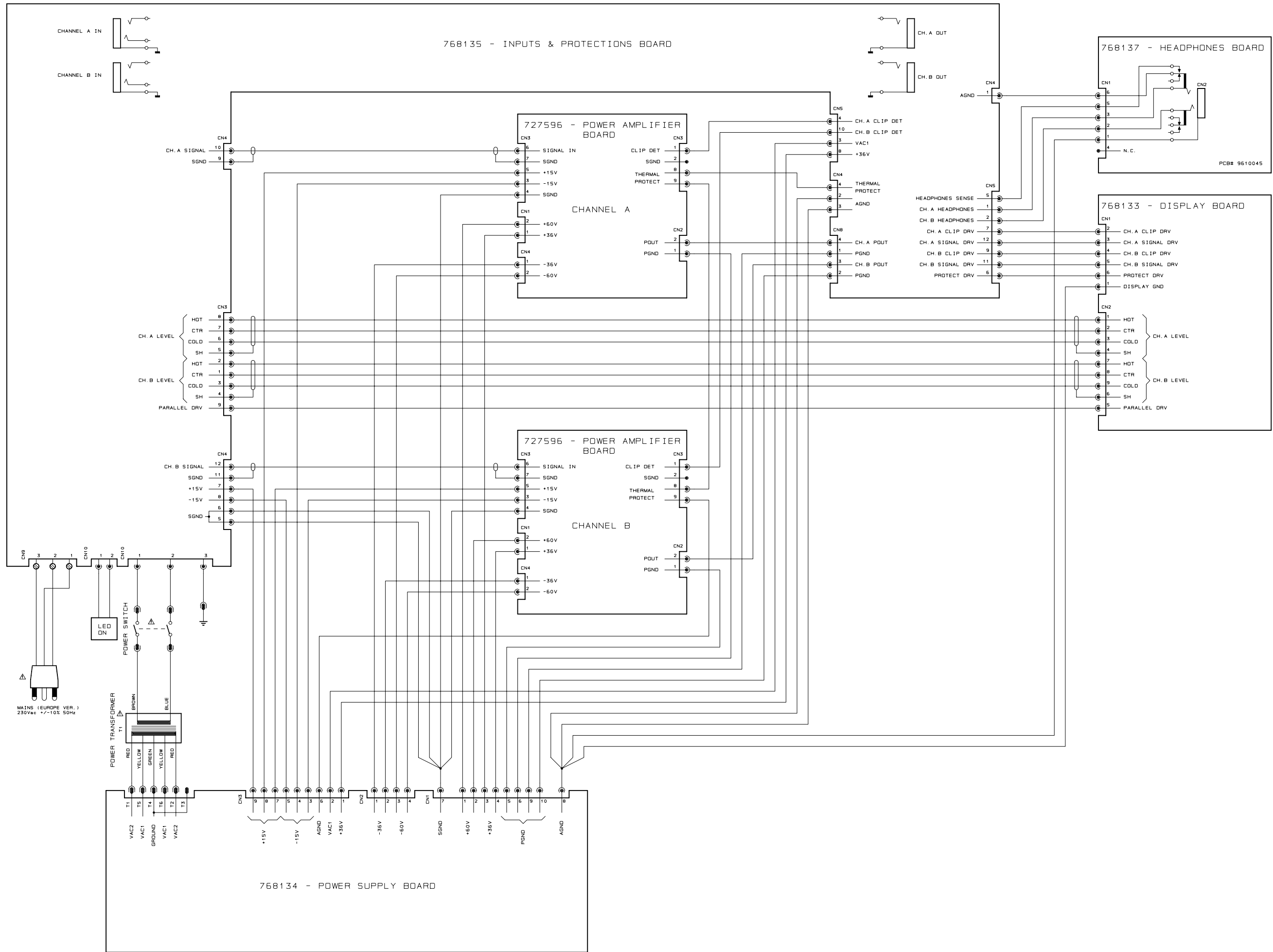

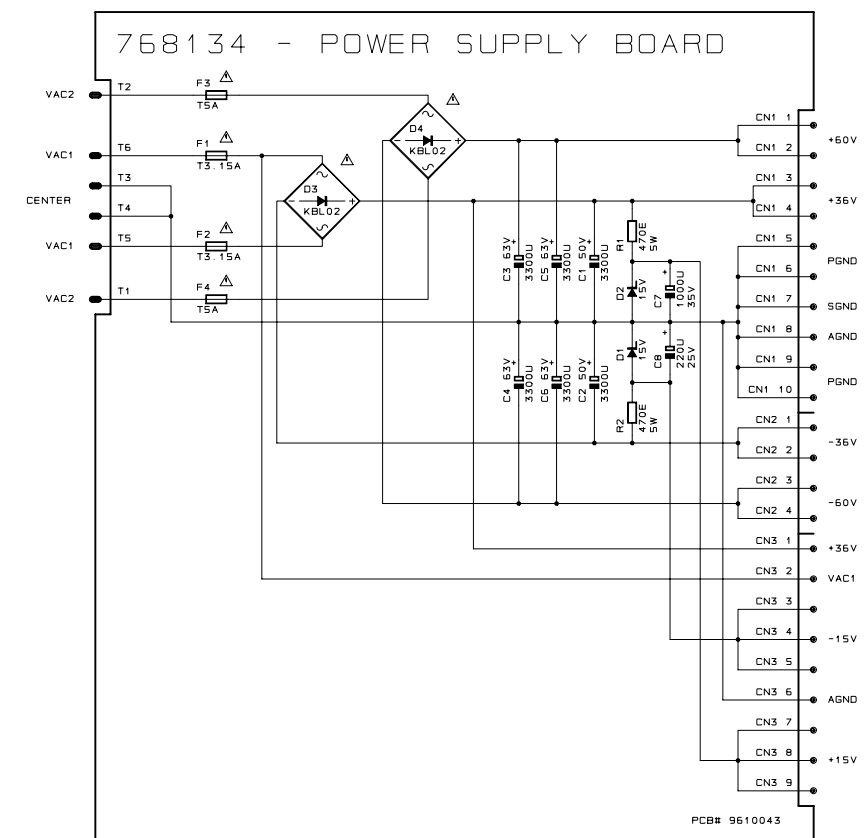
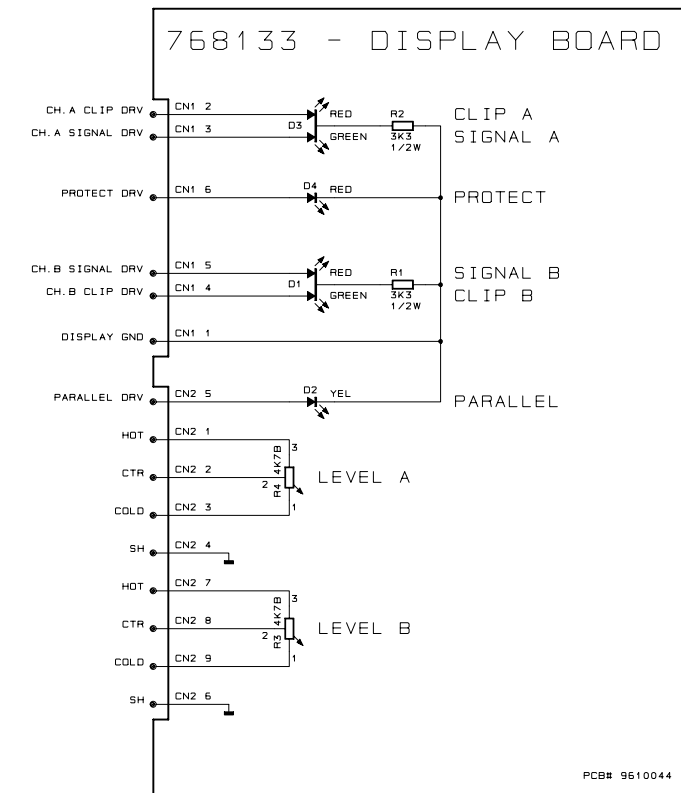
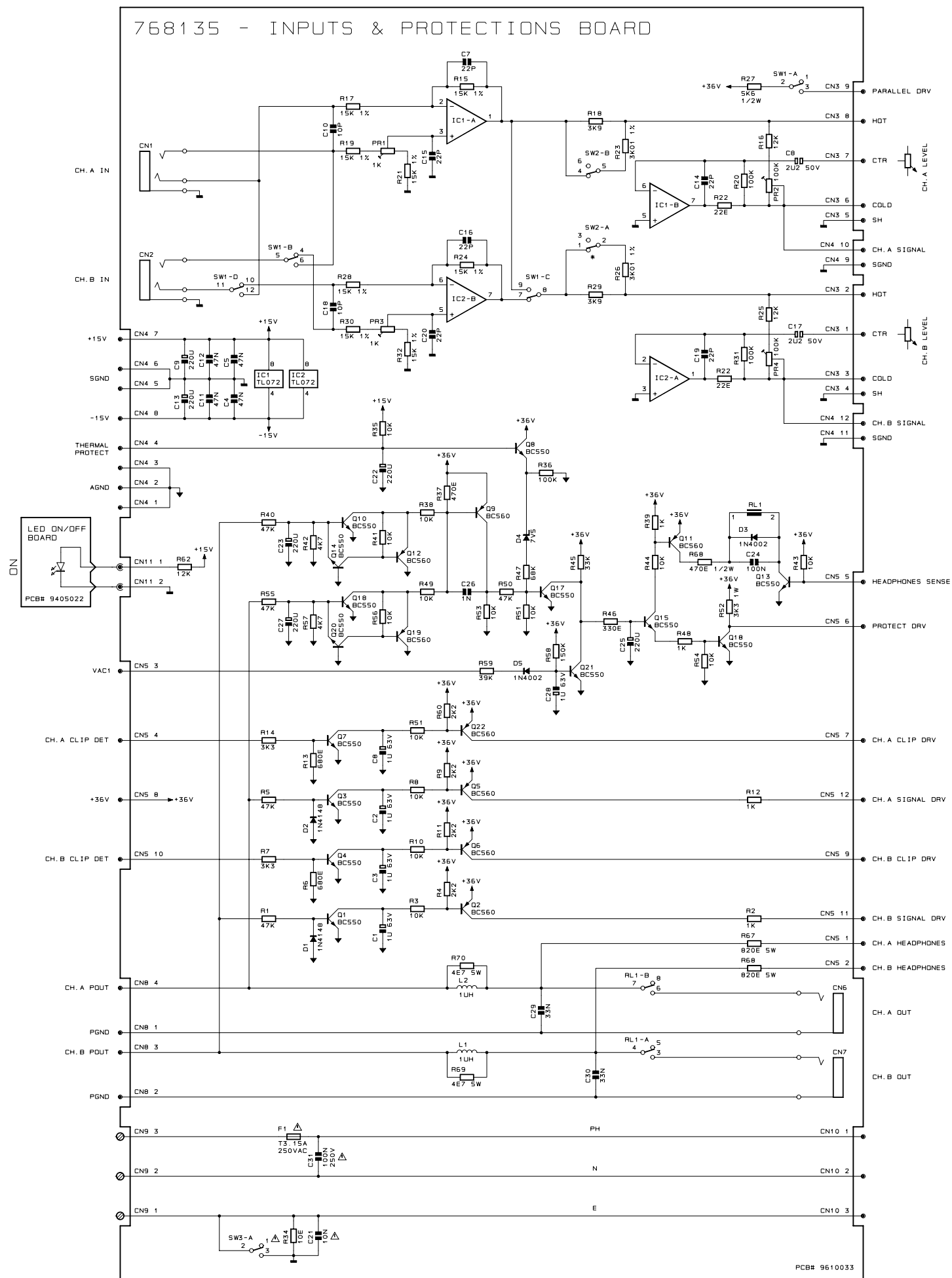



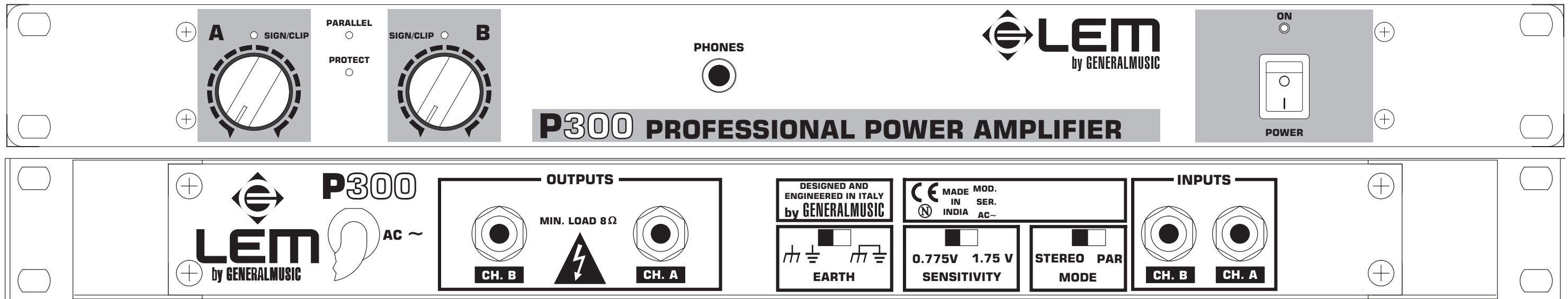

**Spare Part List**

Code	Ref.	Description
<b>Accessories</b>		
277317		Owner's Manual P-Series
<b>Assembly</b>		
667641	MSSCEM01	Cover
667640	FIN27121	Chassis
667639	MSSEB901	Front Panel
657232		Level Knob
347200		Cord Lock
<b>238082</b>	<b>FIN27141</b>	<b>Transformer 300W 230Vac</b>
130294		Mains Cord (EU)
110285		Power Switch
778123	FIN27161	Cables Assembly
<b>HeadPhones &amp; Display Assemblies</b>		
<b>768137</b>	<b>FIN27104</b>	<b>HeadPhones Board (Pcb# 9610045)</b>
140207		Horizontal Female Jack Socket
<b>768138</b>	<b>FIN27106</b>	<b>Led On/Off Board (Pcb# 9405022)</b>
<b>768133</b>	<b>FIN27103</b>	<b>Display Board (Pcb# 9610044)</b>
080742	*	Led 3mm Wide Diffused Red-Grn
080710	*	Led 3mm 60deg Diffused Yel
080705	*	Led 3mm 60deg Diffused Red
074561	RESVRD01	* 4K7 Linear Rotary Potentiometer
<b>Inputs &amp; Protections Assembly</b>		
<b>768135</b>	<b>FIN27101</b>	<b>Inputs &amp; Protections Board (Pcb# 9610033)</b>
230557	*	1uh Hor Coil For Amplifier
140228	*	Horizontal Jack Stereo Socket
140226	*	Horizontal Jack Mono Socket
110307	*	Relay 24V / 2 Switch 5A 250V
110295	*	4sw 2pos Vertical Slider Switch
110293	*	2sw 2pos Slider Switch
100061	*	TL072 Dual J-Fet Operational Amplifier
090194	*	BC560 TO92 LN Pnp Transistor
090183	*	BC550 TO92 LN Npn Transistor
080245	*	7V5 1W 5% Zener Diode
080156	*	1N4002 1A 100V Rectifier Diode
080103	*	1N4148 100mA 75V Signal Diode
070241	*	100K 20% Horizontal Linear Trimmer
070121	*	1K 20% Horizontal Linear Trimmer
060540	*	3K3 1W 5% Resistor
060481	*	820E 5W 10% Resistor
060214	*	4E7 5W 10% Wire Resistor
030085	*	2u2 50V 20% Vert Electrolytic Bipolar Capacitor
<b>Power Supply Assembly</b>		
<b>768134</b>	<b>FIN27102</b>	<b>Power Supply Board (Pcb# 9610043)</b>
110020	*	T5A Fuse 5x20mm (EU)
110003	*	T3.15A Fuse 5x20mm (EU)
080605	*	KBL02 4A 200V Rectifier Diode Bridge
080293	*	15V 1W 5% Zener Diode
060441	*	470E 5W 10% Resistor
030543	*	3300u 63V 20% Snap-In Electrolytic Capacitor

**Dual Power Amplifier Assemblies**

Code	Ref.	Description
<b>727587</b>	<b>FIN27111</b>	<b>Dual Power Amplifier Board (Pcb# 9610042)</b>
<b>727596</b>	*	<b>Power Amplifier Board (Pcb# 9610042) With Heatsink</b>
<b>768136</b>	**	<b>Power Amplifier Board (Pcb# 9610042) without Heatsink</b>
100931	***	MC34081 Single J-Fet Operational Amplifier
090917	***	MJE350 TO126 Pnp Transistor
090916	***	MJE340 TO126 Npn Transistor
090201	***	2N5401 TO92 Pnp Transistor
090200	***	2N5550 TO92 Npn Transistor
090194	***	BC560 TO92 LN Pnp Transistor
090183	***	BC550 TO92 LN Npn Transistor
080261	***	10V 1W 5% Zener Diode
080245	***	7V5 1W 5% Zener Diode
080171	***	FE6B 6A 100V Fast Recovery Diode
080156	***	1N4002 1A 100V Rectifier Diode
080103	***	1N4148 100mA 75V Signal Diode
070084	***	220E 20% Vertical Linear Trimmer
070065	***	100E 20% Vertical Linear Trimmer
060075	***	0E33 5W 5% Wire Resistor
030247	***	10u 25V 20% Vert Electrolytic Bipolar Capacitor
340750	**	TO126 Mica Washer
340078	**	TO220 Insulated Bush
090920	**	MJE802 TO126 Npn Darl Transistor
090863	**	TIP36C TO218 Pnp Transistor
090862	**	TIP35C TO218 Npn Transistor
080819	**	Ptc 70 PTH59F04BG222TS

**Note:**

Each spare part is single quantity unless otherwise specified.

Asterisk prefix explanation:

- Omitted = First level spare part.
- One asterisk = Second level, part of previous listed first level part.
- Two asterisk = Third level, part of previous listed second level part.
- Three asterisk = .....

Any request for not above mentioned part must encompass specific description including:

- 1) Model name,
- 2) Section name,
- 3) Module code,
- 4) Reference name,
- 5) Quantity number.