

ARCAM DELTA

DELTA 90 INTEGRATED STEREO AMPLIFIER

Disc Input

The disc input will accept either moving magnet (M.M.) or moving coil (M.C.) cartridges. For moving coil cartridges an MC60 preamplifier is switched into circuit using the switch at the rear of the amplifier. The moving magnet and RIAA equalisation stage is based around a NE5534 low noise op-amp. Capacitors C1 and C2 provide rejection of R.F. interference on the input. Frequency dependent feedback for RIAA correction is provided by networks R5 and C5 at low frequencies and R6 and C6 at high frequencies. Capacitor C3 provides high frequency stabilisation of the IC.

Input and Record Selection

Line level signal from the disc stage output or any other input can be selected for amplification by the listen switch. A second record switch independently selects signals for routing to tape outputs. Note that the record switch is wired to prevent tape 1 input from being fed tape 1 output to prevent feedback problems. C.D. input signals are attenuated by R8 and R9 to match other line levels.

Line amplifier

Signal passes via the listen switch and volume control to a line amplifier stage which provides 18dB of gain. Transistors Q1 and Q2 provide gain which is set by R16 and R17. Transistors Q3 and Q4 are a current source load for the collector of Q2.

D.C. bias for this stage is provided by R220, R221 via R13.

Tone control and direct switch

A non-inverting tone control based around IC2 allows a limited range boost and cut (approx. ± 7 dB) of bass and treble. Bass and treble control potentiometers vary the feedback around IC2 with frequency. The resistors on either ends of each potentiometer limit the range of boost and cut.

Signal to the power amplifier is taken from the tone control output when the direct switch is out or directly from the line amplifier when the switch is in. To prevent switching clicks caused by differing DC levels on C12 and C17, equal voltages are maintained on both capacitors via R29, R30.

Power Amplifier

The Power Amplifier has a single transistor input stage rather than the more common long tailed pair. Signal on Q5 base modulates the collector current and the resultant voltage variation drive class A amplifier Q7 via emitter follower Q6. Transistor Q7 is loaded by a current source Q8, Q9. An A.C. signal equal in amplitude to the power amplifier output appears on the collector of Q7. For negative half cycles driver transistor Q13 and output transistor Q15 provide the current handling capability to drive the loudspeaker load. Similarly on positive half cycles Q12 and Q14 provide the same function. The amplifier operates in class AB mode with a standing current of approximately 30mA in the output stage transistors Q14, Q15. The output stage is biased in this condition by the voltage across R42 which is set by current source Q8, Q9. Preset potentiometer RV1 allows adjustment of the current source and consequently the output stage standing current.

Resistors R58 and R59 limit the possibility of the thermal runaway together with Q8 which is mounted adjacent to the heatsink to allow thermal feedback to the current source. Two identical protection stages based on Q10 and Q11 sense output current across R58 and R59 and limit the drive to the base of Q12/Q13 if overcurrent or overvoltage threatens to damage the output transistors.

Feedback from the amplifier output is returned to the emitter of the first stage transistor Q5 via R36. Resistors R35, R36 define the amplifier gain.

Stability against high frequency oscillation in the amplifier is maintained by C23, C21 and R37 and also C22.

There is a D.C. servo I.C.3 which provides D.C. bias to the input stage and maintains a low D.C. offset on the loudspeaker output. The circuit functions by having an extremely large gain at D.C. but very little gain at audio frequencies. Capacitor C20 and R34 are the main servo time constant with residual filtering by C19. I.C.3 is powered by the preamplifier 15V supplies.

Power for the input and class A stage is filtered by use of D213, C203 and D214, C204 to provide isolation from the output stage.

Speaker protection relays and on/off mute

The amplifier output is connected to the output terminals via a relay which performs 2 functions. On switching on the power there is a 5 second time delay before the relay closes, on switchoff the relay opens immediately. Bangs and pops are thus prevented from reaching the speakers. The relay circuit also monitors the D.C. offset on both loudspeaker outputs and if this is greater than approximately ± 0.7 Volt the relays will open, protecting loudspeakers from D.C. current.

Components R215, C220 provide the switch on delay. When C220 charges to above 15.7 Volts Q208 switches on and in turn Q209 switches on both relays. Resistor R219 provides some positive feedback for positive action.

Note that for C220 to charge up Q206 and Q207 must be off. Any D.C. offset on either power amplifier will cause one of these transistors to turn on. Capacitors C218, C219 prevent normal signals from operating the circuit.

With the A.C. power on, C217 will be negatively charged by A.C. from the transformer secondary rectified by D207. On switchoff this A.C. disappears and C217 becomes positively charged via R214. Transistor Q207 will switch on and consequently the circuit will open the relays.

Preamplifier power supplies

Positive and negative fifteen volt supplies for all preamplifier stages and the D.C. servos are provided by two regulator circuits of similar configuration. In the positive regulator the main power supply of 44V is dropped to approximately 25 volts by R201. Transistor Q201 is switched on by current through R202 and R203 and the emitter of Q201 rises in voltage until at approximately 15.7 volts D201 conducts and turns on Q202. Transistor Q202 then robs current from the base of Q201 so that a stable operating point is reached. Capacitor C208 provides high frequency stability for the circuit. The negative regulator operates in an identical way.

Component substitution

Most of the components in the amplifier can if necessary be replaced by similar types or manufacturer providing voltage, current and tolerance ratings are equal or better. The main exceptions to this are the driver and output transistors Q12,13,14,15. These transistors are gain matched so that if Q12 needs relacing then Q13 should also be changed. Similarly Q14 and Q15 should be replaced together.

By replacing in matched pairs the distortion measurements will remain low, also any later failure by partial damage in the other device will be avoided.

SAFETY WARNING

Replacement of the mains fuse

This fuse promotes the main protection to the whole amplifier and must NEVER be replaced by a fuse of higher rating or different type. The fuse value is listed below:

Supply Voltage	Fuse rating
110 - 120V	3.15A(T)
220 - 240V	1.25A(T)

Disc Input

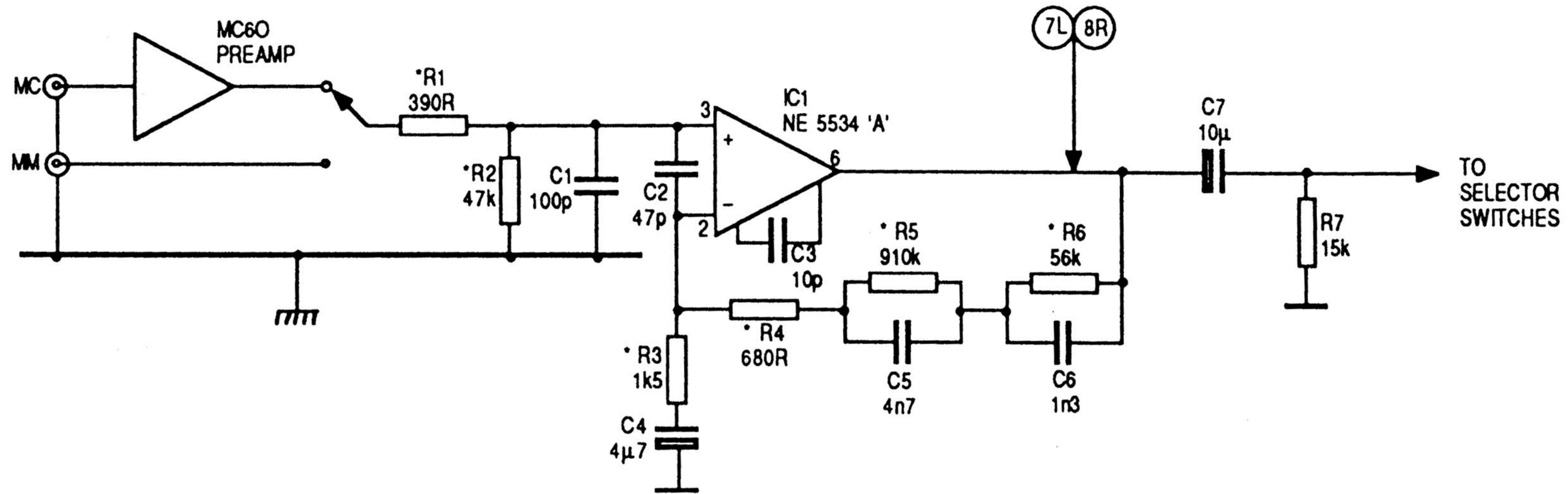

N.B. FOR RIGHT HAND CHANNEL, ADD 100 TO ALL COMPONENT REFERENCE NUMBERS.

* COMPONENTS ARE 1% TOLERANCE METAL FILM.

A&R CAMBRIDGE LTD.

**ARCAM DELTA 90
CIRCUIT DIAGRAM 1 / 6
ISSUE 3 9.12.87
SERIAL NOS 001-4800**

Input and Record Switching

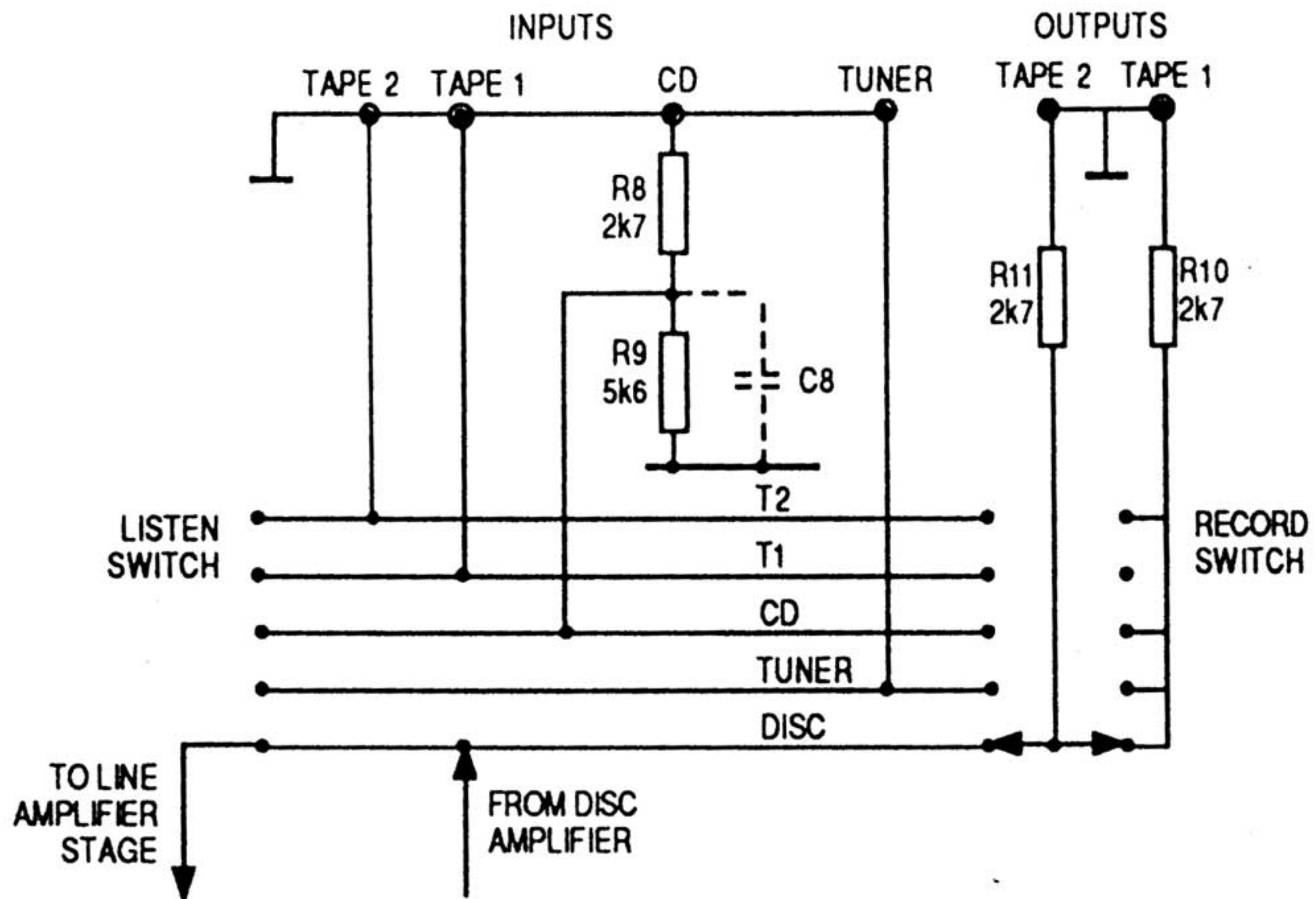

A&R CAMBRIDGE LTD.

**ARCAM DELTA 90
CIRCUIT DIAGRAM 2 / 6
ISSUE 3 9.12.87
SERIAL NOS 001 - 4800**

Line Amplifier

Tone Controls

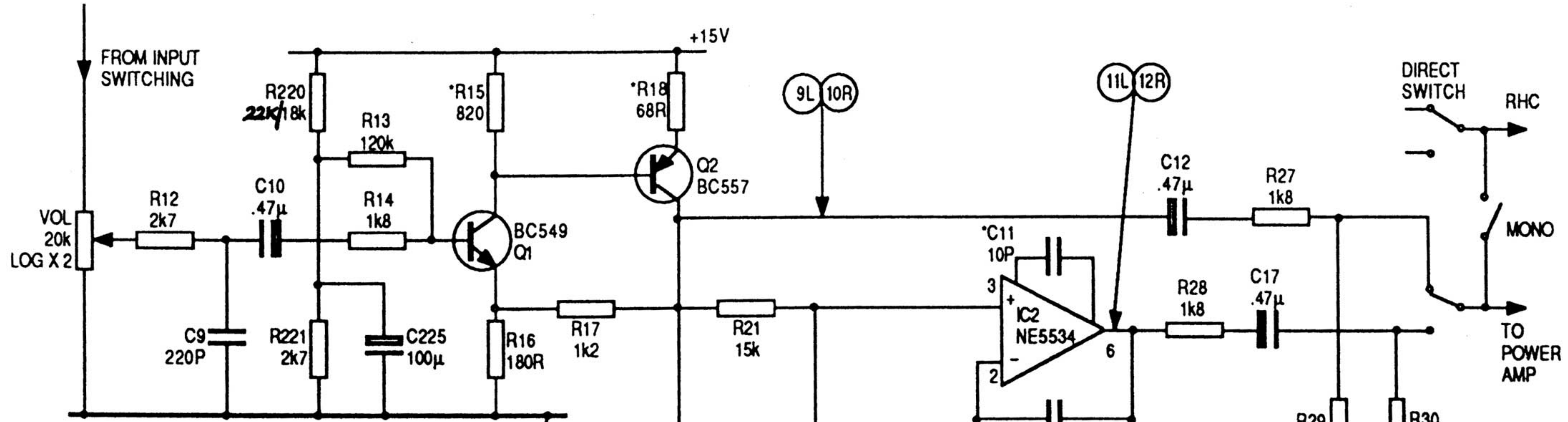

DIRECT SWITCH CCT. (early units)

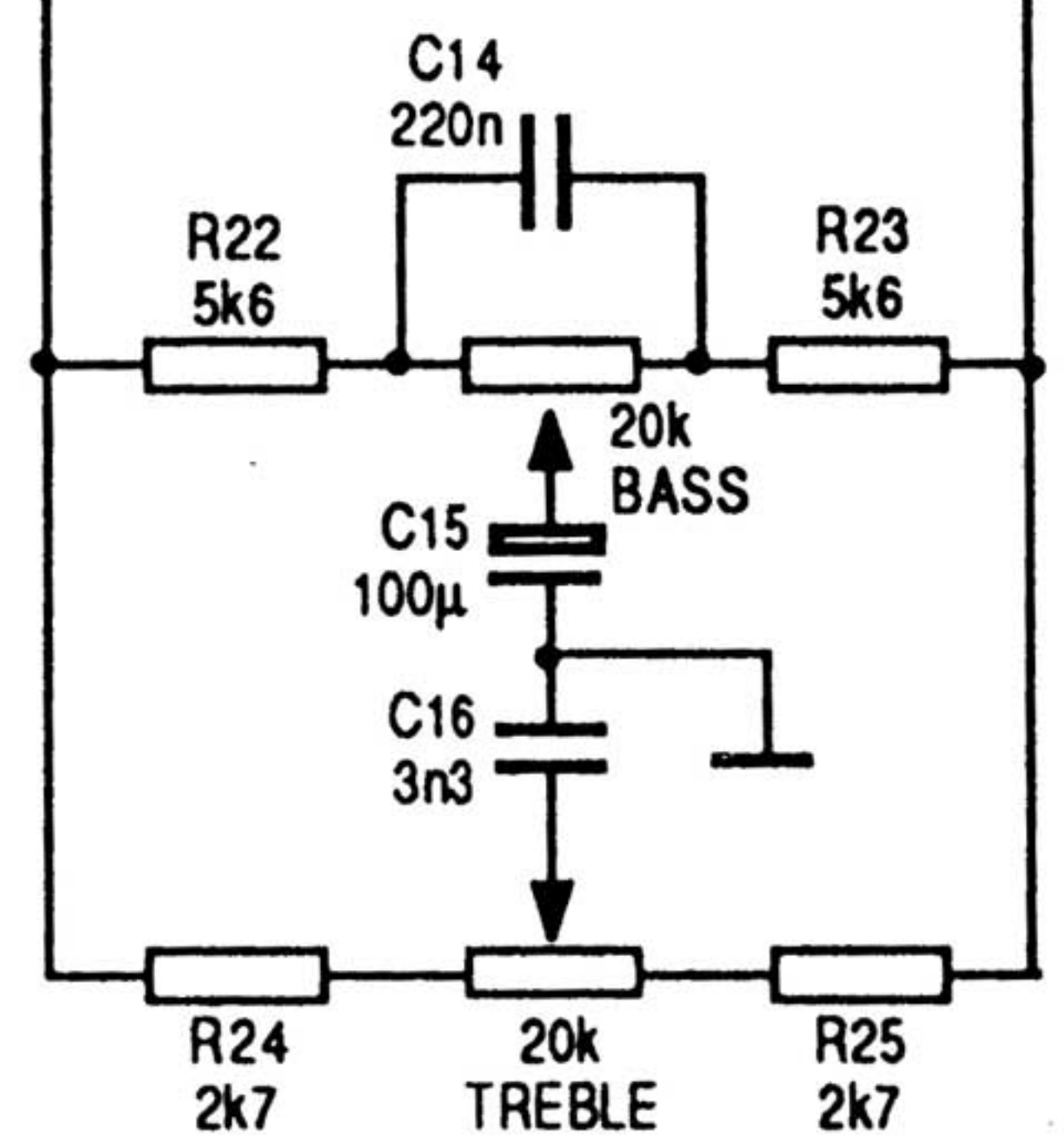
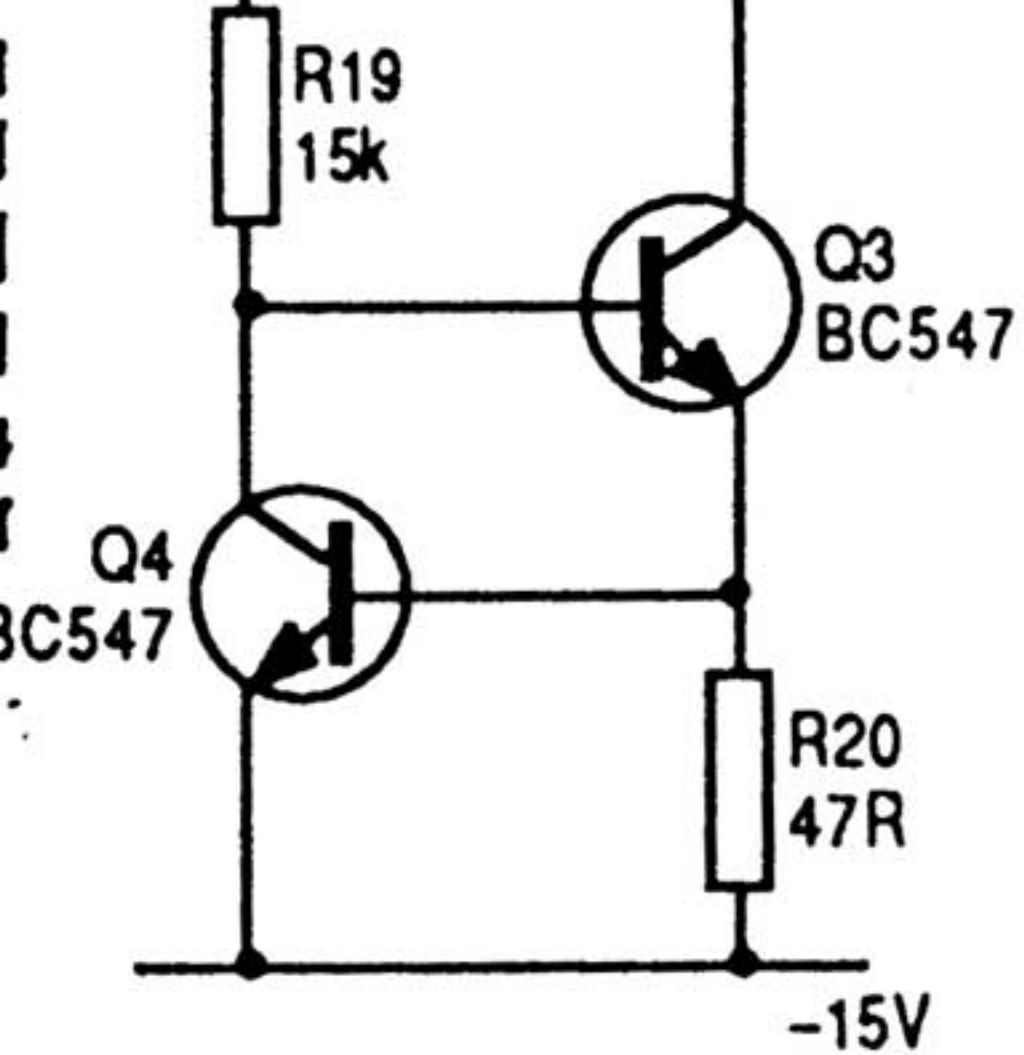
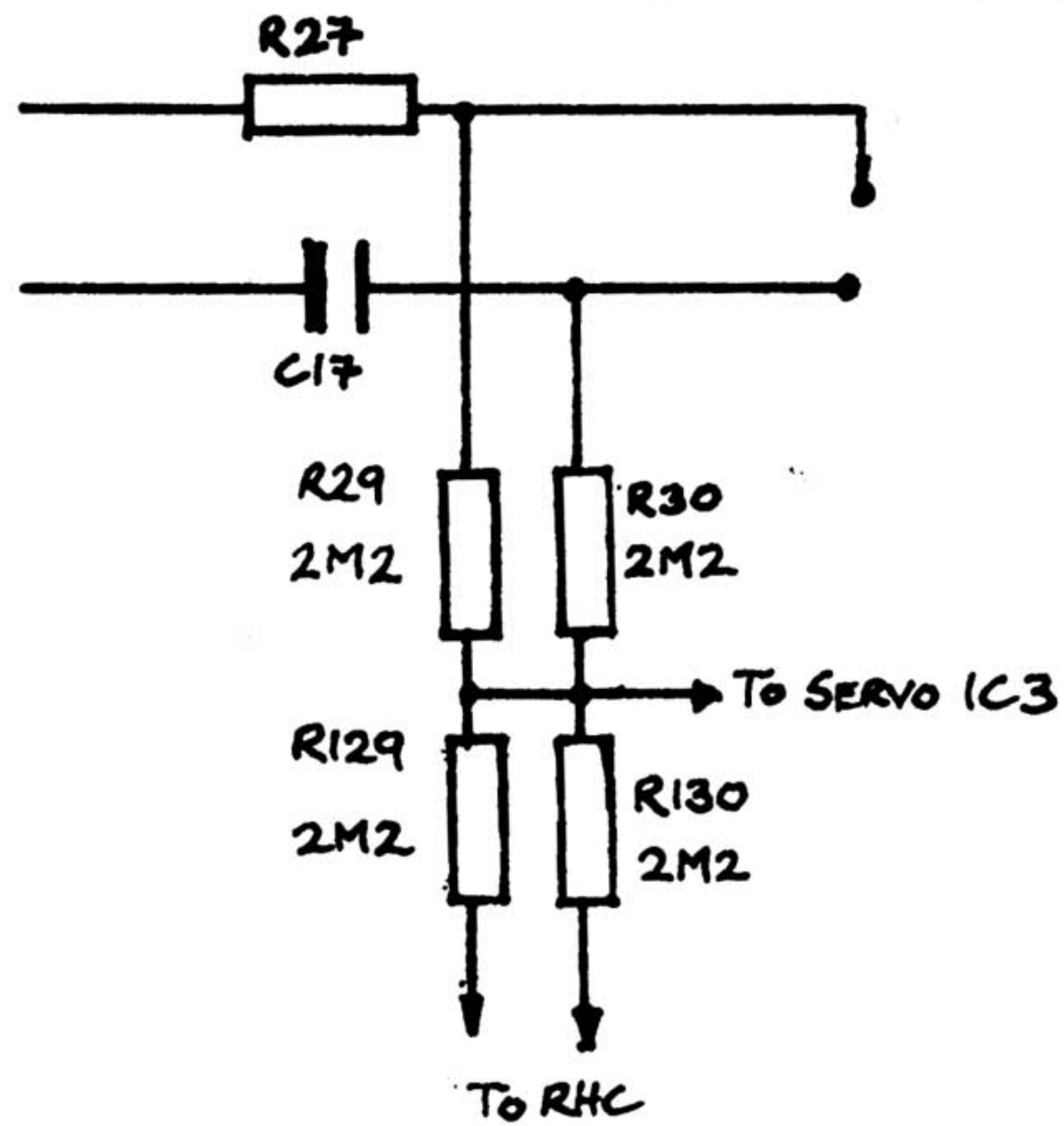

A&R CAMBRIDGE LTD.
 ARCAM DELTA 90
 CIRCUIT DIAGRAM 3 / 6
 ISSUE 3 9.12.87
 SERIAL NOS 001 - 4800

Power Amplifier

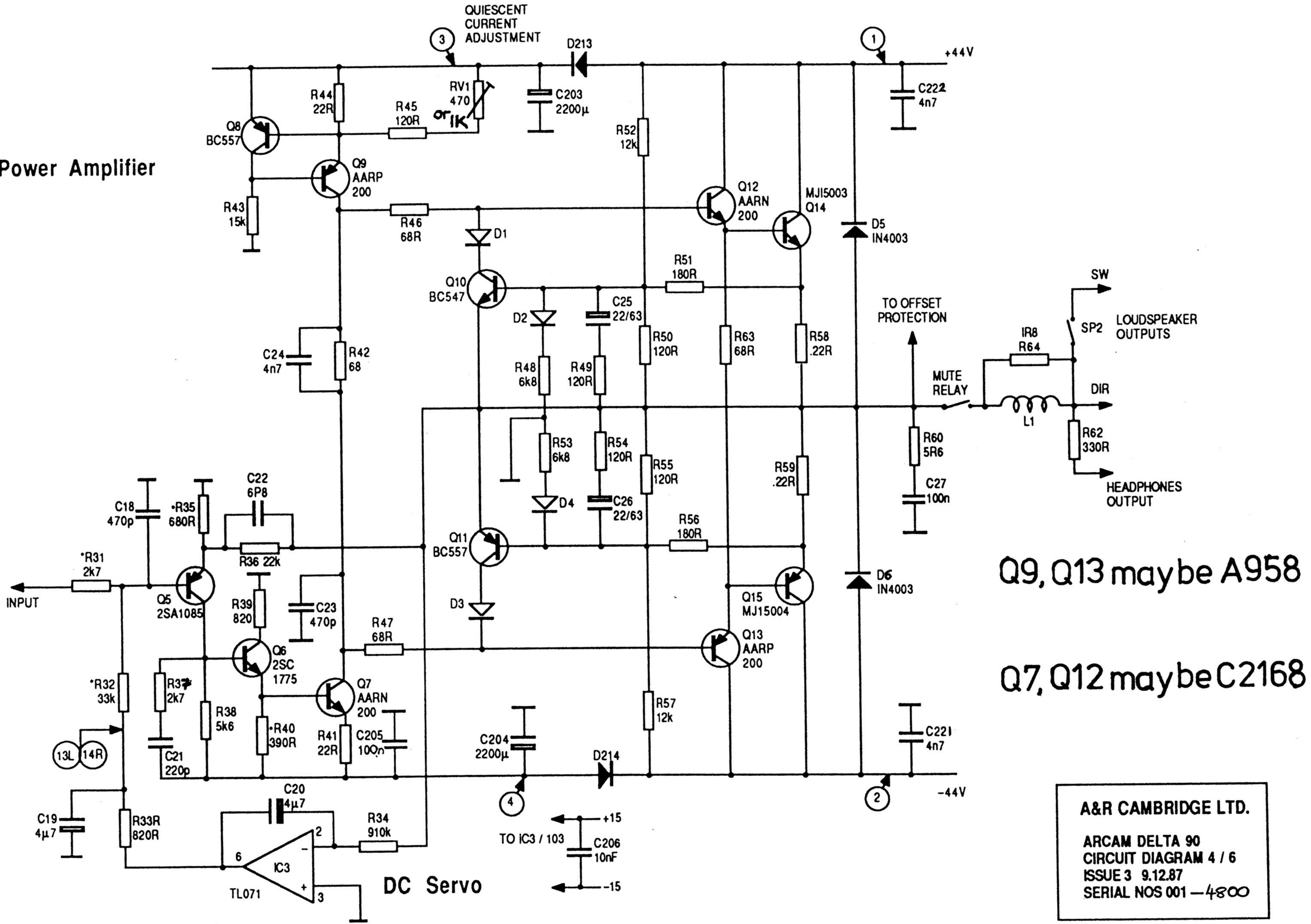

Q9, Q13 maybe A958

Q7, Q12 maybe C2168

A&R CAMBRIDGE LTD.
 ARCAM DELTA 90
 CIRCUIT DIAGRAM 4 / 6
 ISSUE 3 9.12.87
 SERIAL NOS 001 - 4800

On/Off Mute and DC Offset Speaker Protection

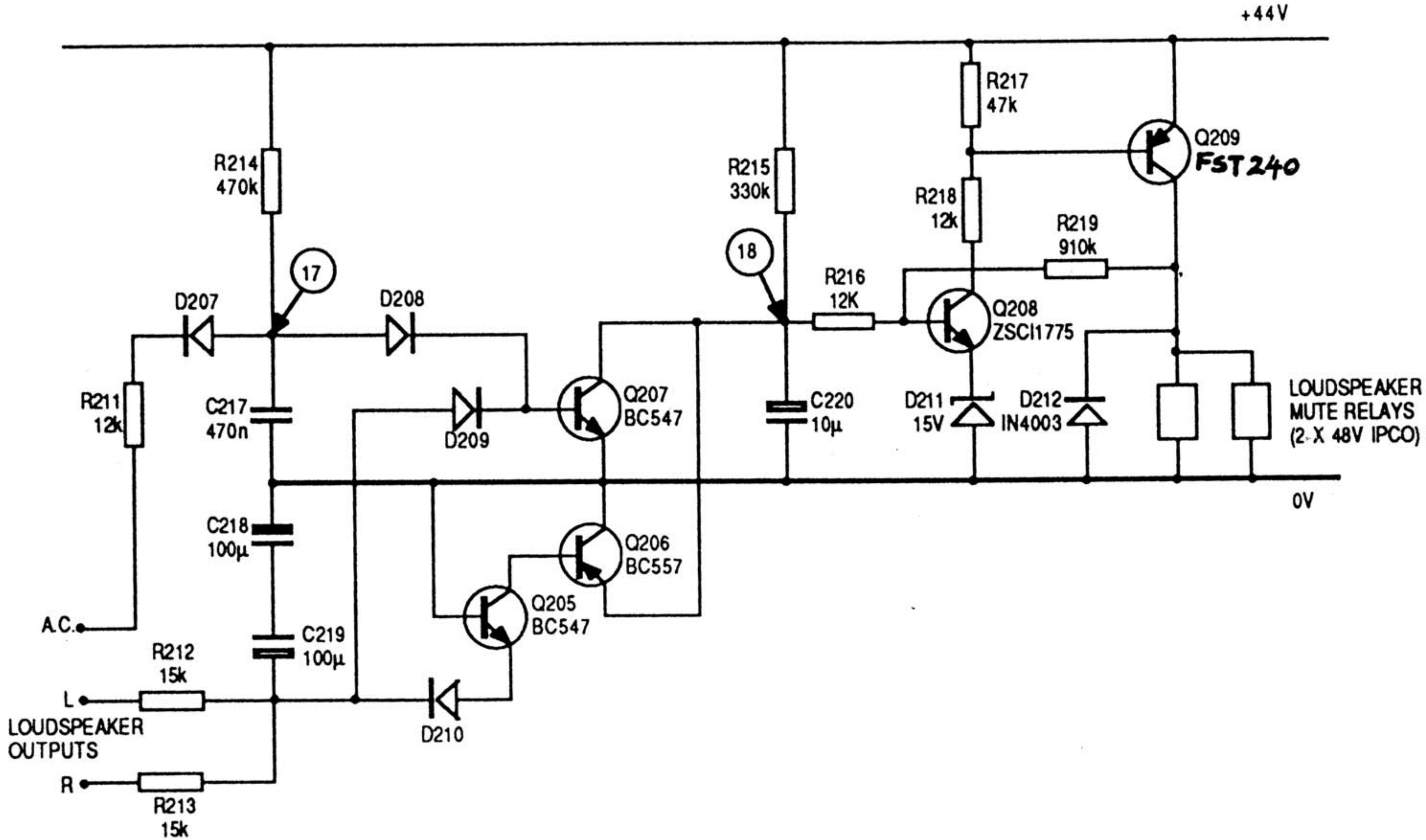

A&R CAMBRIDGE LTD.

ARCAM DELTA 90
CIRCUIT DIAGRAM 5 / 6
ISSUE 3 9.12.87
SERIAL NOS 001 - 4800

Main Power Supply

±15V Discrete Regulators

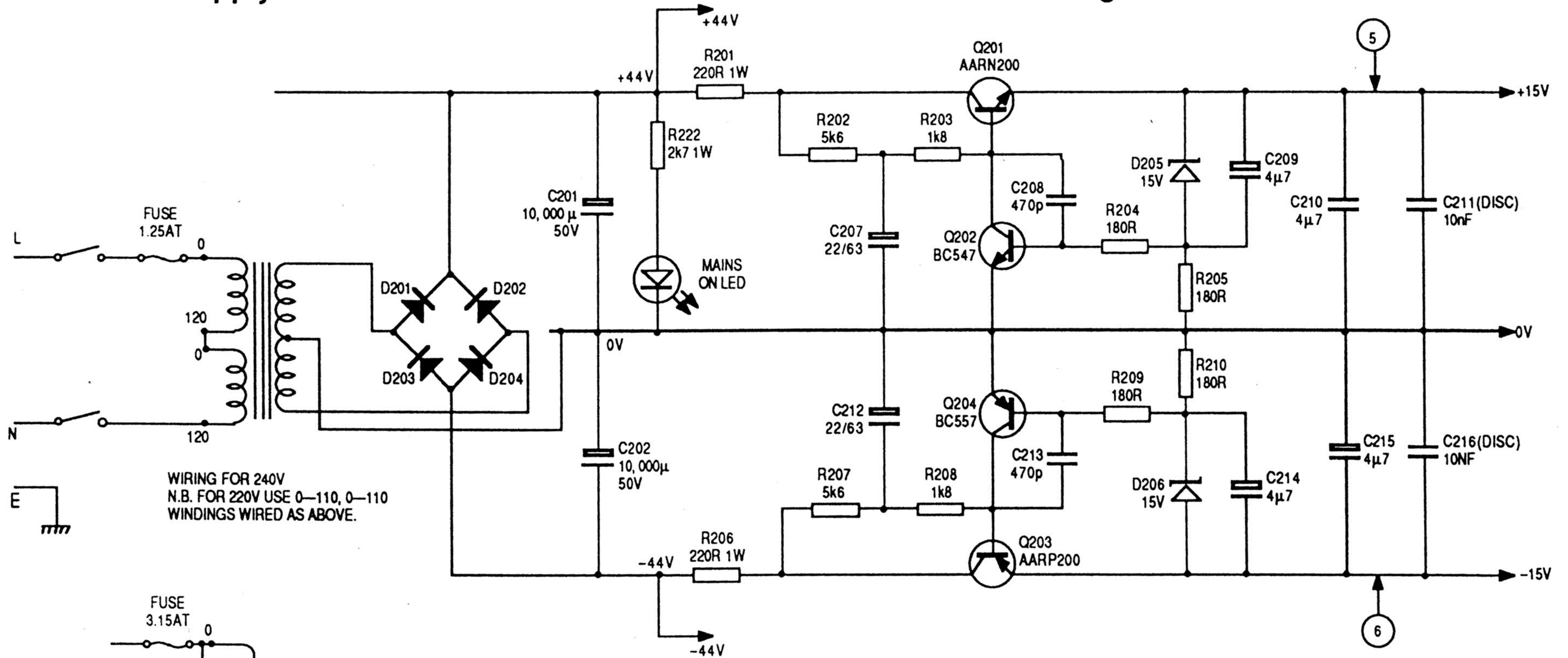

WIRING FOR 240V
N.B. FOR 220V USE 0-110, 0-110
WINDINGS WIRED AS ABOVE.

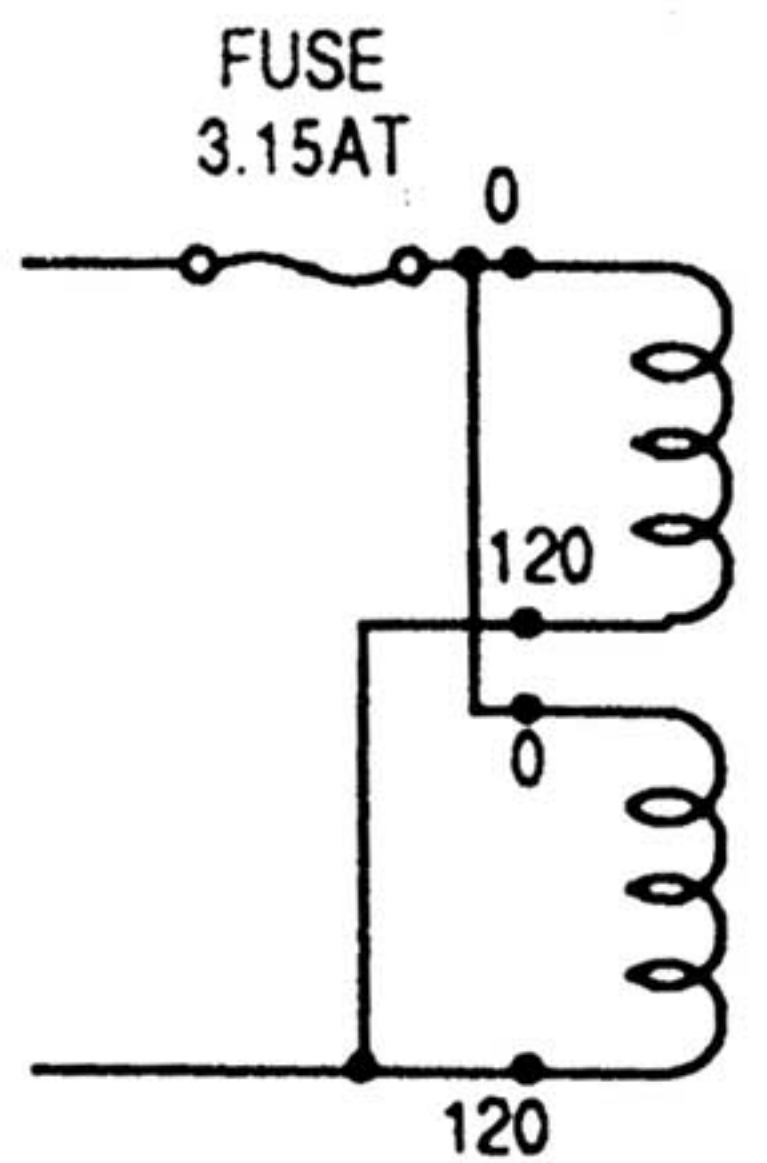

WIRING FOR 120V
N.B. FOR 110V USE 0-110, 0-110
WINDINGS WIRED AS ABOVE.

Q 201 maybe C2168
Q 203 maybe A 958

SAFETY WARNING:

ALWAYS REPLACE WITH THE SAME FUSE RATING AND TYPE.
DISCONNECT SUPPLY BEFORE CHANGING FUSE.

A&R CAMBRIDGE LTD.
ARCAM DELTA 90
CIRCUIT DIAGRAM 6 / 6
ISSUE 3 9.12.87
SERIAL NOS 001 - 4800