

PRL POWER AMPLIFIERS



PRL500



PRL900



PRL1300

Technical Service Manual

Technical Service Manual

PROEL
SOUND REINFORCEMENT

PRL500 - 900 - 1300 Test & Calibration

Required Test Equipment:

- Function Generator
- 20 Mhz Dual-channel Oscilloscope
- Power Load Bank (4Ω - 350W min.)
- 2 Digital Multimeters (Tester)
- PROEL Test Cable
- Variac (0V ac – 230V ac, 15A)

Test Procedure

Connections:

- Connect the Function Generator output on CH1 input Jack or XLR socket.
- Connect the Power Load Bank with Speakon on the output sockets.
- Connect the Dual-channel Oscilloscope on Binding Post outputs.
- Connect the PROEL Test Cable to the TP Test Points of the amplifier and the two other side terminals to the Testers setted at 200mV range.
- Set the Variac at 0V and connect its output to the mains cable of the amplifier.

Verifying:

- Switch on the amplifier, then slowly rise the Variac voltage till 230V and check the value on the Testers is the most low as possible (few mV). If not check the correct mounting of MJ21193/MJ21194 transistors.
- In same time the relays are activated and the protect red led turns off.
- Set the amplifier in parallel mode.
- Set the Function Generator on 1KHz sinewave at 0.2V RMS and check on the Oscilloscope monitor the output signals have the same amplitude and phase.
- Then rise the Function Generator amplitude till 1V RMS and check on the Oscilloscope monitor the output signal is not squared.
- Set the amplifier in bridge mode.
- Set the Function Generator on 1KHz sinewave at 0.2V RMS and check on the Oscilloscope monitor the output signals have the same amplitude and opposite phase.
- Then rise the Function Generator amplitude till 1V RMS and check on the Oscilloscope monitor the output signal is not squared.

PRL500 - 900 - 1300 Bias Calibration

Required Test Equipment:

- Function Generator
- 20 Mhz Dual-channel Oscilloscope
- Power Load Bank (4 Ω - 350W min.)
- Variac (0V ac – 230V ac, 15A)

Test Procedure

Connections:

- Connect the Function Generator output on CH1 input Jack or XLR socket.
- Connect the Power Load Bank with Speakon on the output sockets.
- Connect the Dual-channel Oscilloscope on Binding Post outputs.
- Set the Variac at 0V and connect its output to the mains cable of the amplifier.

Verifying:

- Switch on the amplifier, then rise the Variac voltage till 230V. In same time the relays are activated and the protect red led turns off.
- Set the amplifier in parallel mode.
- Set the Function Generator on 1KHz sinewave at 0.2V RMS and check on the Oscilloscope monitor the output signals have the same amplitude and phase.
- Verify that on the sinewave there is not the “crossover distortion”. (*)

Only if the “crossover distortion” is present adjust the trimmer VR1 for CH1, VR2 for CH2.

(*)

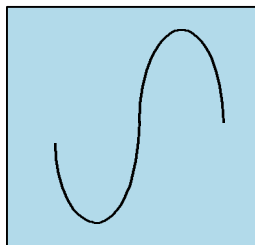

**sinewave without
“crossover distortion”**

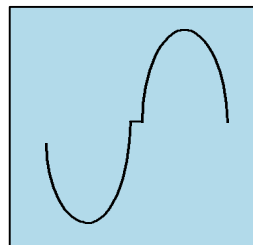

**sinewave with
“crossover distortion”**

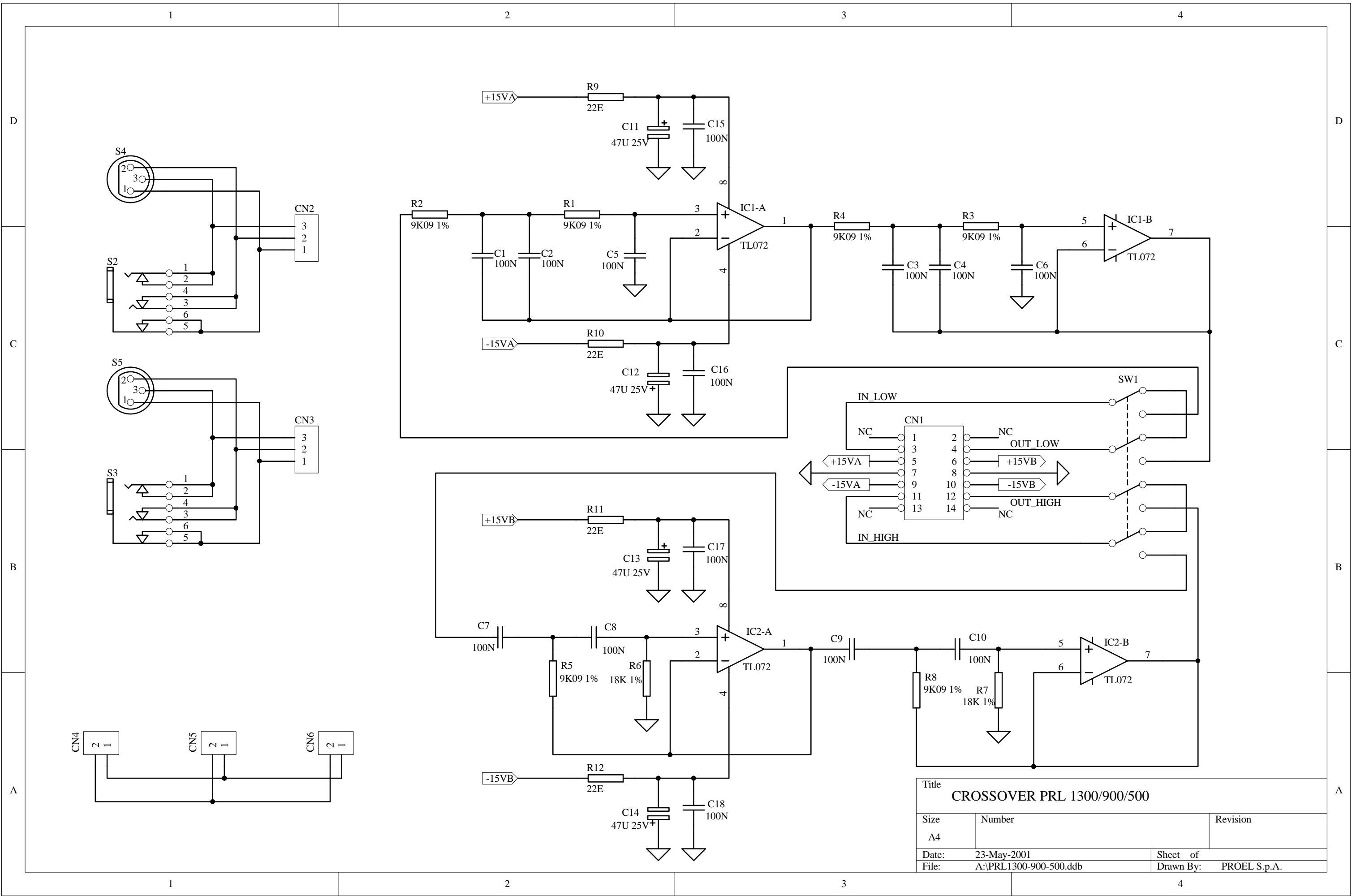

Title CROSSOVER PRL 1300/900/500		
Size A4	Number	Revision
Date: 23-May-2001	Sheet of	
File: A:\PRL1300-900-500.ddb	Drawn By:	PROEL S.p.A.

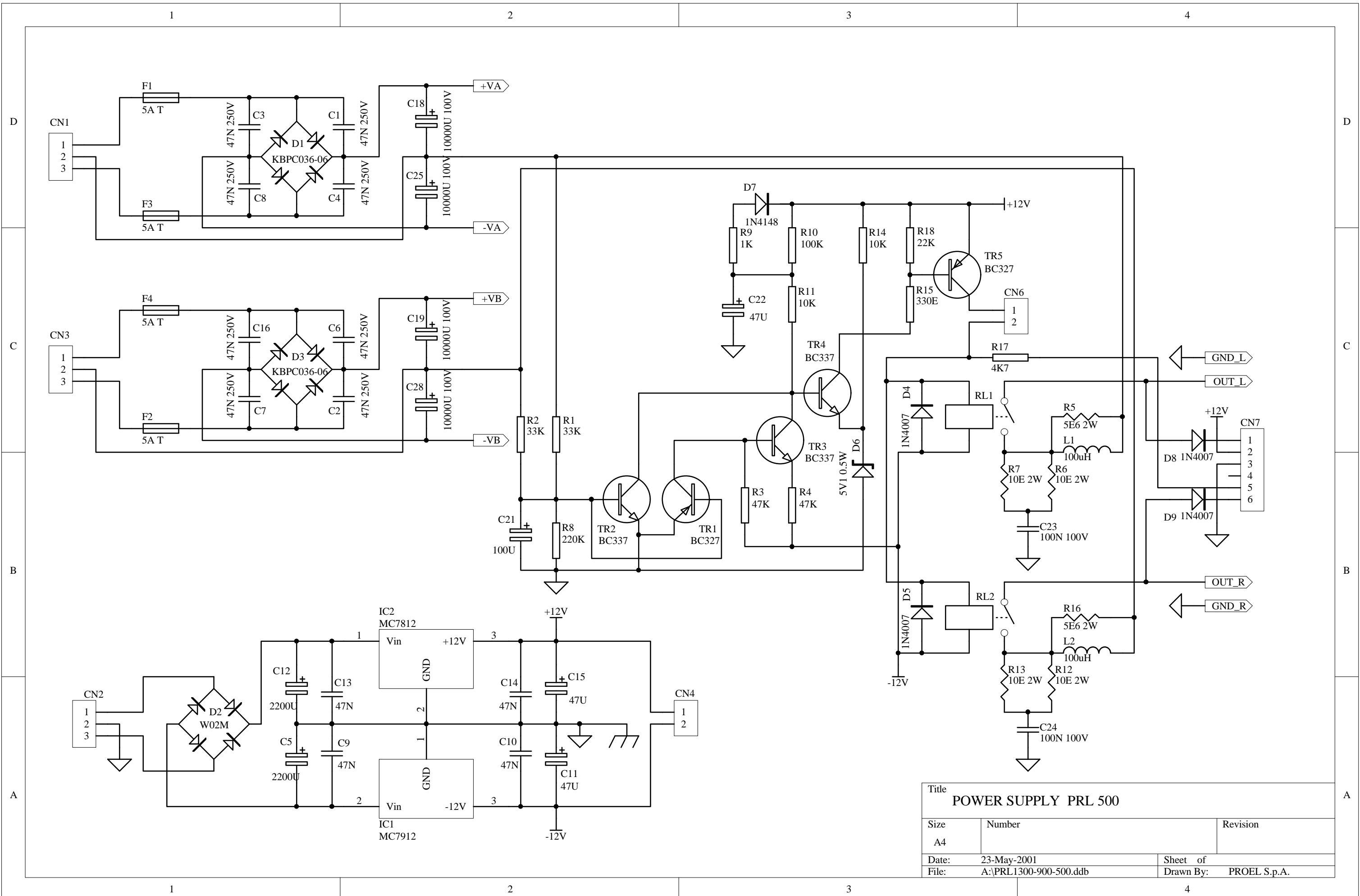

Title POWER SUPPLY PRL 500		
Size A4	Number	Revision
Date: 23-May-2001	Sheet of	
File: A:\PRL1300-900-500.ddb	Drawn By: PROEL S.p.A.	

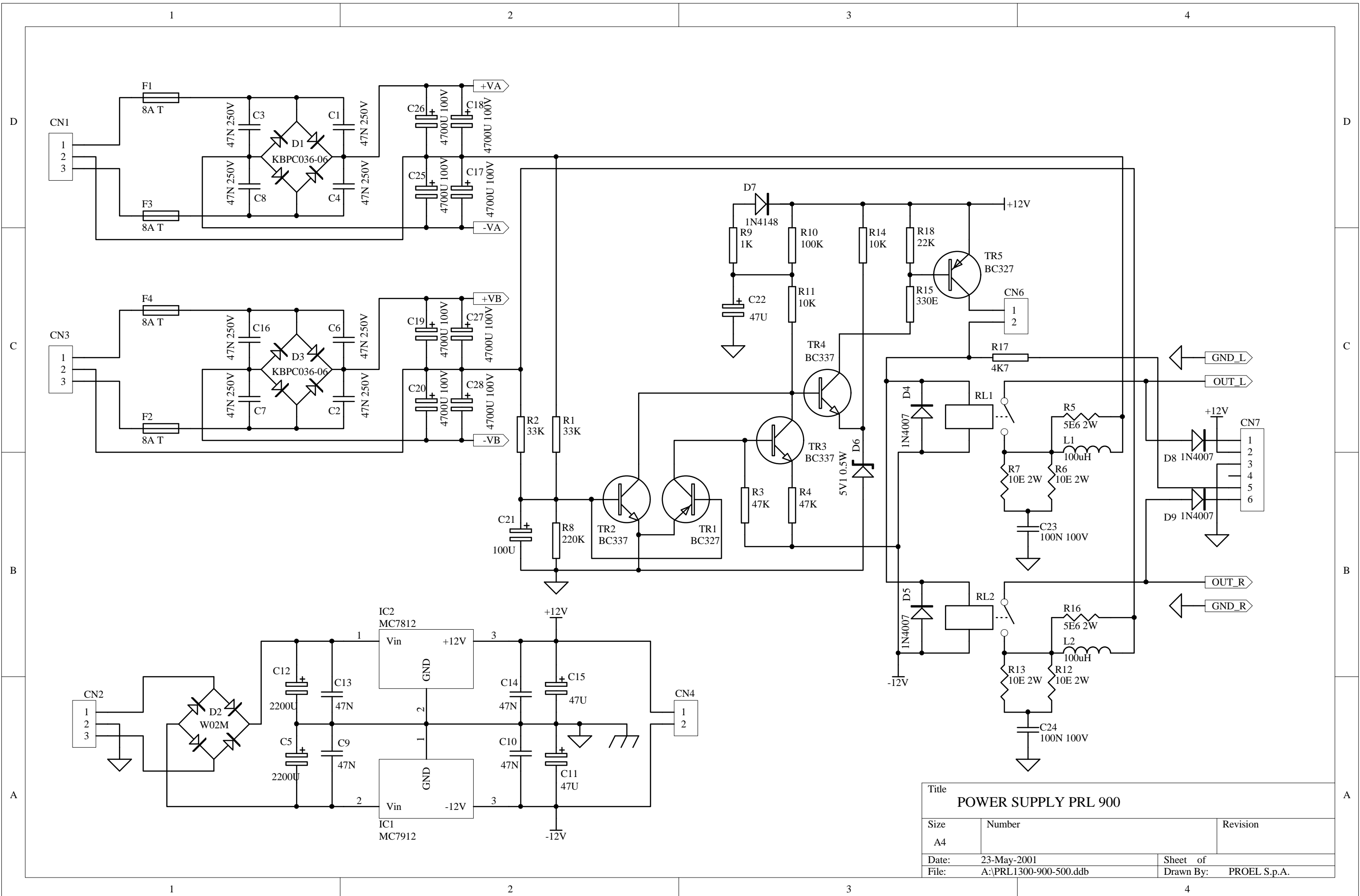

Title		
POWER SUPPLY PRL 900		
Size	Number	Revision
A4		
Date:	23-May-2001	Sheet of
File:	A:\PRL1300-900-500.ddb	Drawn By: PROEL S.p.A.

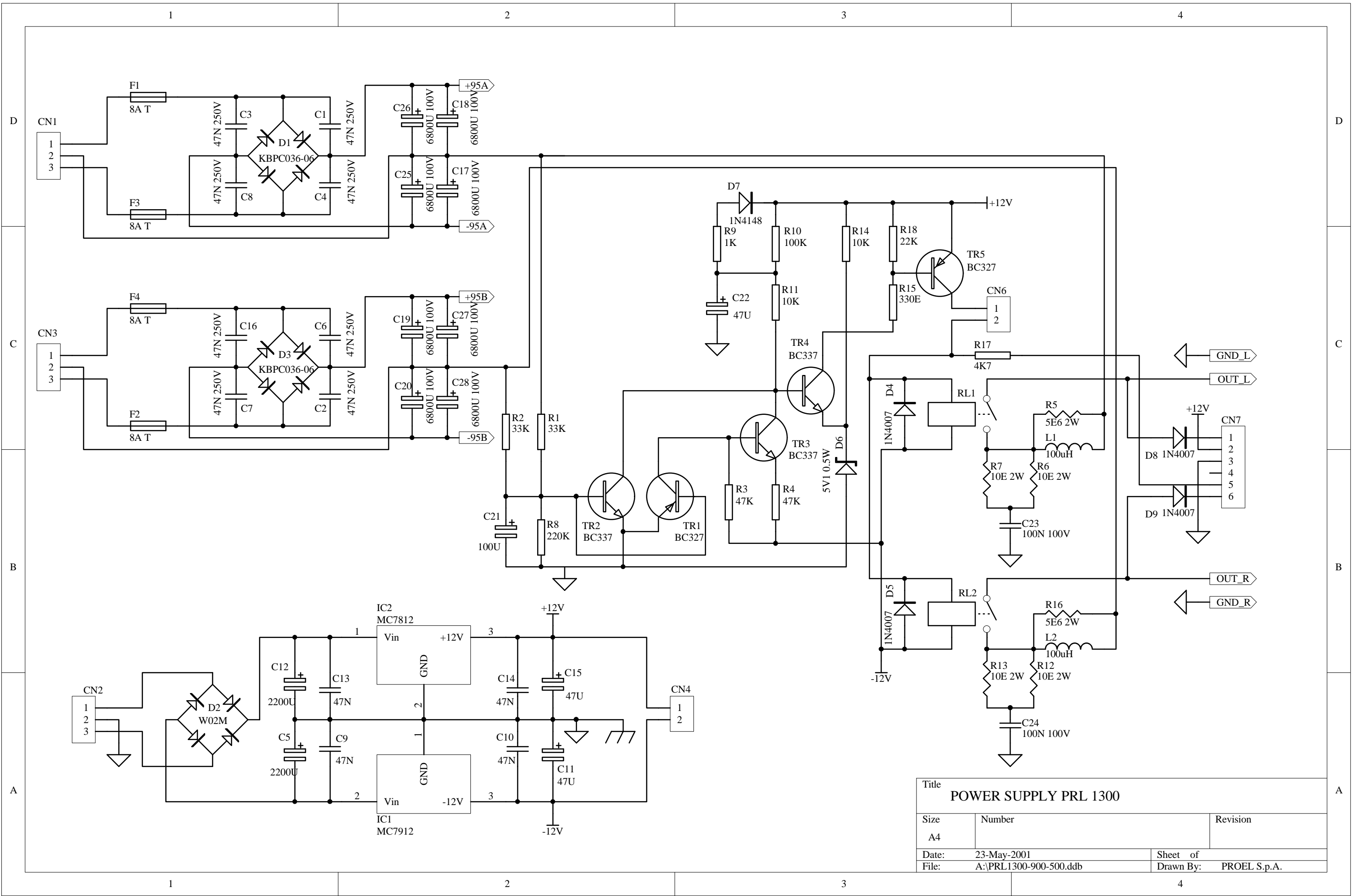

Title		
POWER SUPPLY PRL 1300		
Size	Number	Revision
A4		
Date:	23-May-2001	Sheet of
File:	A:\PRL1300-900-500.ddb	Drawn By: PROEL S.p.A.

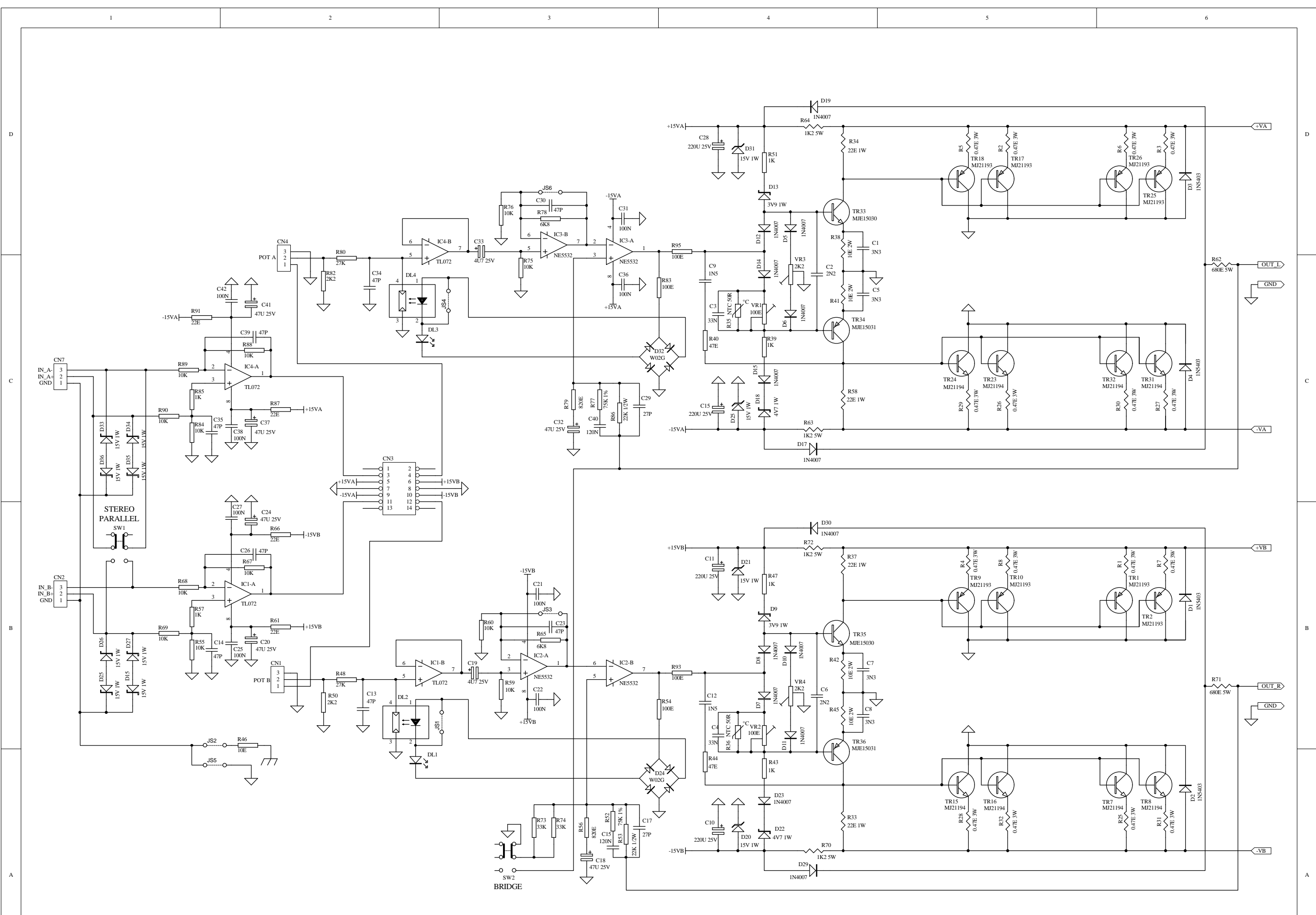

Title		
STEREO POWER AMP. PRL 500		
Size	Number	Revision
C		
Date:	23-May-2001	Sheet of
File:	A:\PRL1300-500-500.ddb	Drawn By:
		PROEL S.p.A.

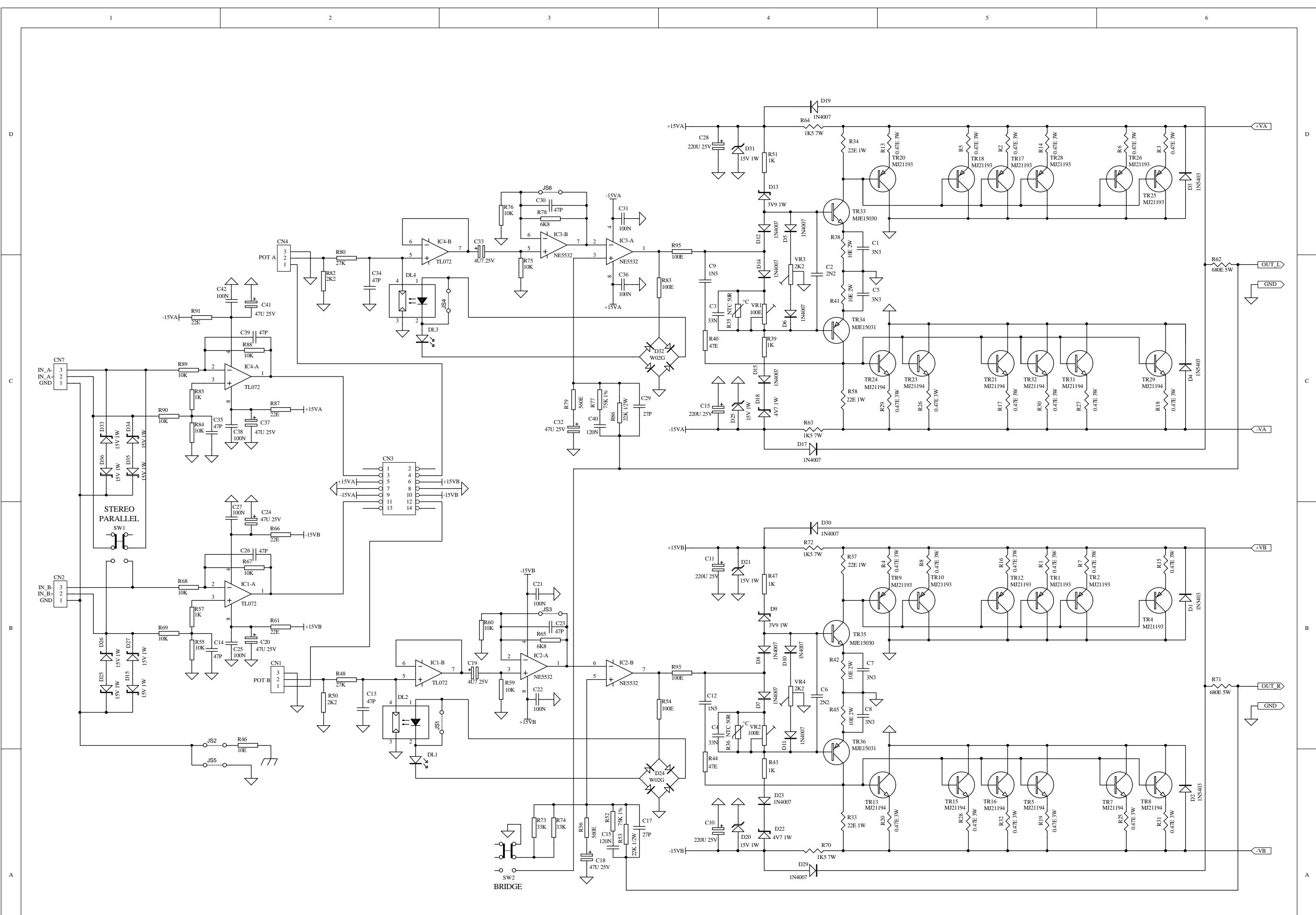

Title		
STEREO POWER AMP. PRL 900		
Size	Number	Revision
C		
Date:	23-May-2001	Sheet of
File:	A:\PRL1300-900-500.ddb	Drawn By:
		PROEL S.p.A.

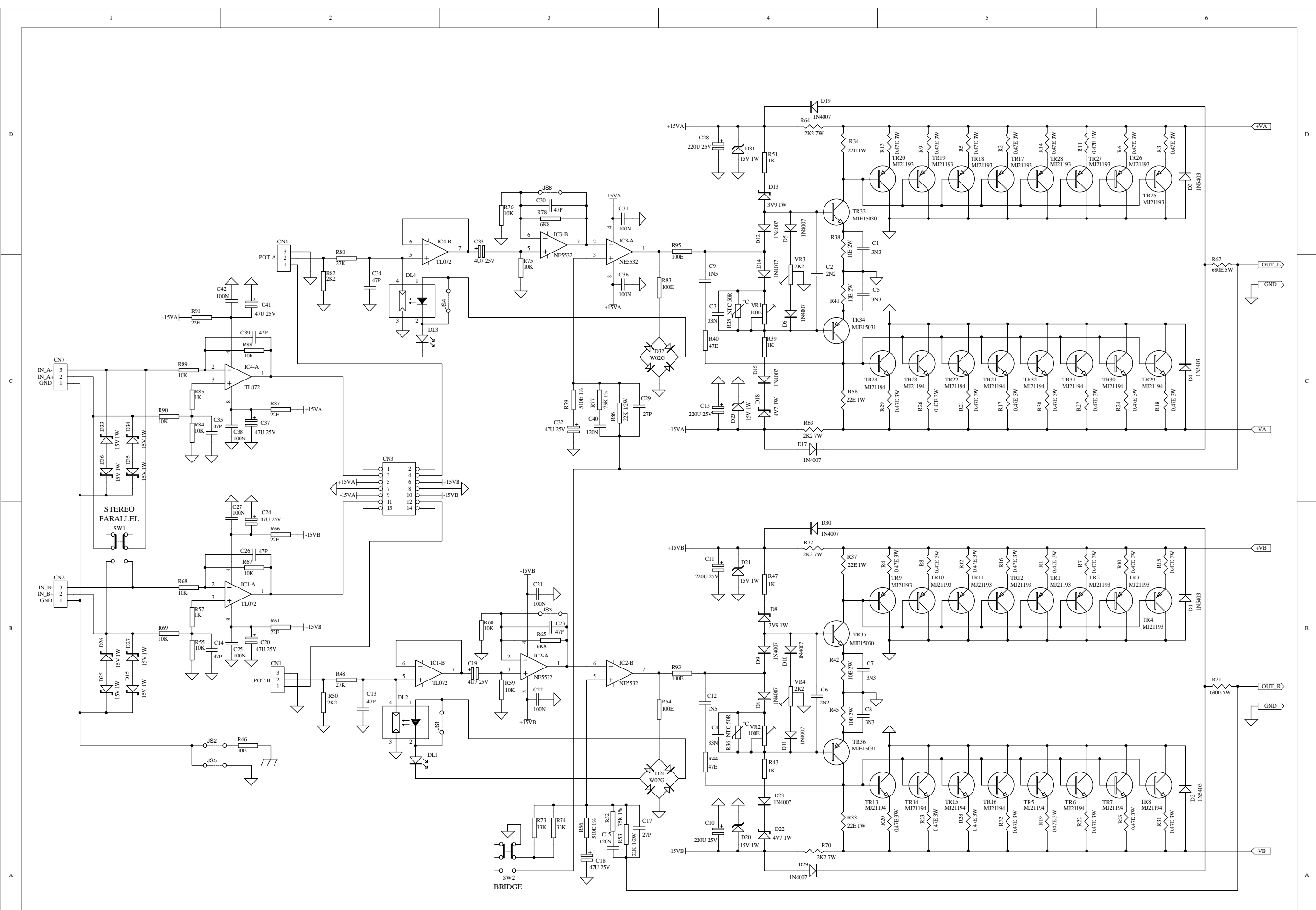

Title		
STEREO POWER AMP. PRL 1300		
Size	Number	Revision
C		
Date:	23-May-2001	Sheet of
File:	A:\PRL1300-500-500.ddb	Drawn By:
		PROEL S.p.A.