

An aerial photograph of a tropical storm's eye over the ocean. The eye is a bright, circular center surrounded by a dark, swirling ring of clouds. The surrounding ocean is a deep blue, and the sky is a lighter blue. The text "STORM 7/9/10f" is overlaid in white, bold, sans-serif font across the center of the image.

STORM 7/9/10f



Direct Drive System



3 Way Wash



i-Sensor (7 Sensing)



Smart Control & Wide Display



Total Care Programs



Auto Restart

- ✓ Family Design for 7 to 10 kg
- ✓ Transparent & Opaque Lid
- ✓ Free Silver ...

Specification

Model	STORM 7	STORM 9	STORM 10f
Design Look 			
Capacity	7kg	9kg	10kg
Washing Type	Direct Drive+3 Way Wash		
Dimension (WHD,mm)	540x540x910	590X606X958	632X670X1005
Total Care Program	Fuzzy, Delicate, Economy, Jean, Wool, Silent, Favorite, Tub Clean		
Power Consumption(Wh)	110	150	
Water Consumption()	60 (Ex-Large)	77 (Ex-Large)	
Waterfalls	Single+Centrifugal 6	Triple+Centrifugal 6	
Delay Start	3 ~ 48 hour		
LED Display	88:88		
Auto Restart	0		
Stuffing Q'ty(40ft)	160	114	102

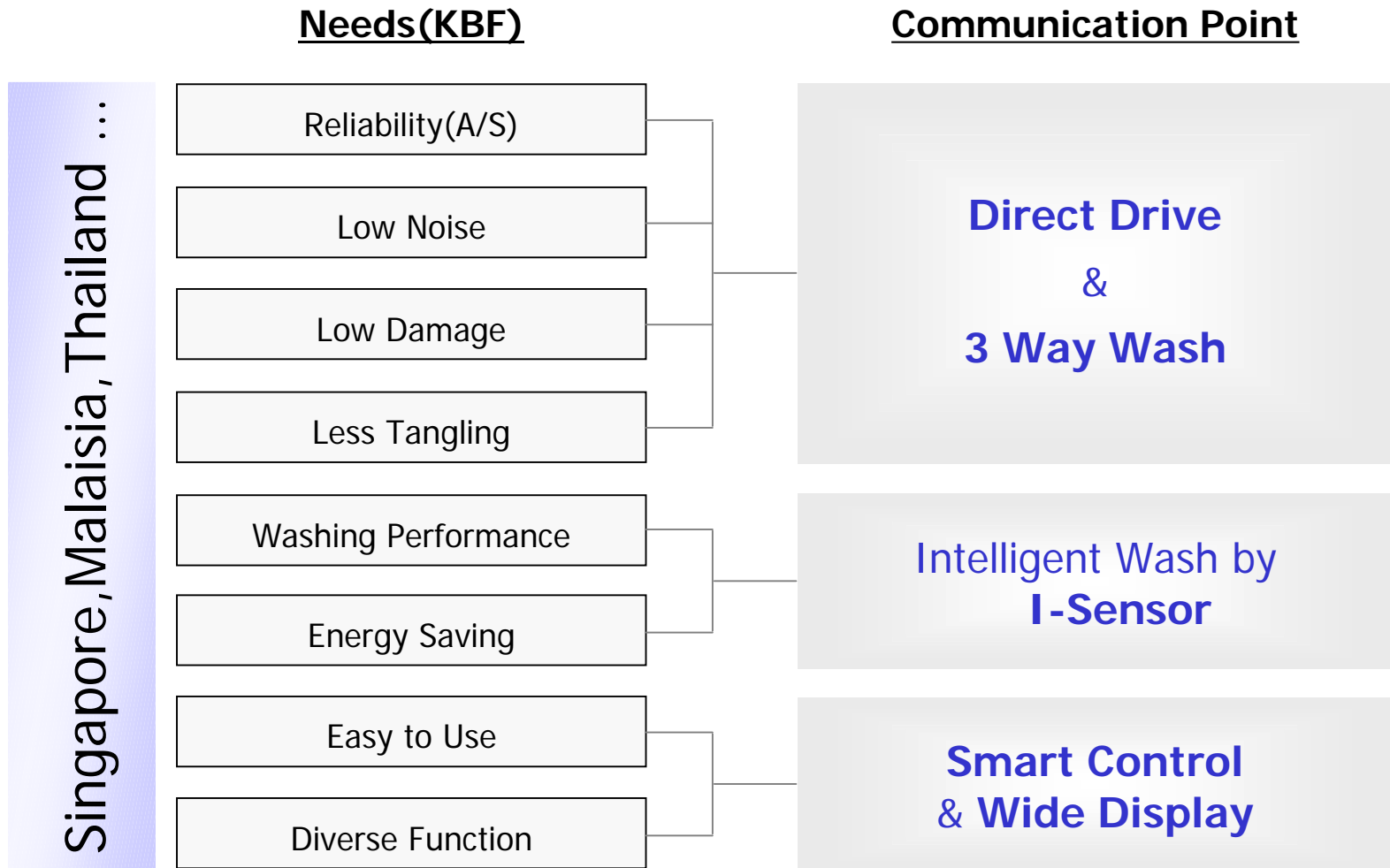

'02 Customer Needs Research(Singapore, Malaysia, Thailand ...)

New Concept DD

World First Outer Rotor Induction Direct Drive System

No-Belt Type



3 Way Wash

- TurboDrum, Drum Rotating, Centrifugal Wash
Set 3 individual washing types into one combined Program by Laundry Type



TurboDrum

Drum Rotating

Centrifugal



World First I-Sensor

- Hardnes, Detergent, Temp. Sensing
FIS* Wash Time, Pattern, Rinse Time, Spin Time... Optimizer
FIS: Fuzzy Inference System



Detergent Amount



Water Hardness

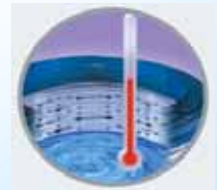

Water Temperature

Smart Control & Display

- Wide Digital Display (4 digit read-out)
- Multi-stage Water Level (7 levels)
- Total Care Programs
-8 Wash Programs(Favorite, Tub Clean...)



Non-DD

- Induction(AC) Control
- Pulsator & Drum
- Belt Type
 - TurboDrum Wash

Merits

- Washability
- Cost

Demerits

- Water Consumption
- Noise
- Durability

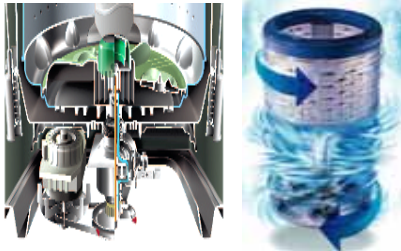

Inverter DD

- Inverter(DC) Control
- One Body
- Direct Drive
 - Drum Rotating Wash
 - Centrifugal Wash

Merits

- Water Consumption
- Noise
- Durability

Demerits

- Washability
- Cost

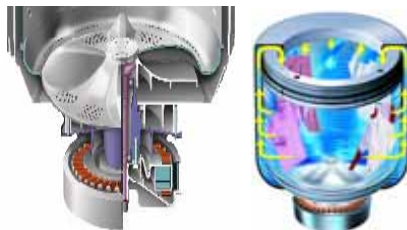

New Concept DD

- Outer Rotor Induction DD
- Pulsator / Drum
 - 3 Way Wash

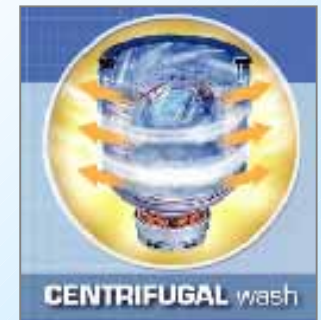
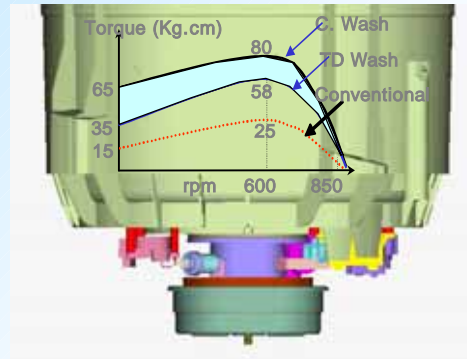

3 Way Wash

TurboDrum Wash



Drum Rotating Wash



Centrifugal Wash



Performance

LG 100% as standard

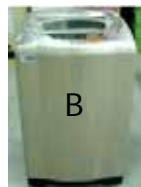

Washability

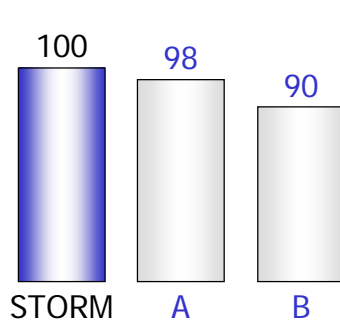

Water Consumption(/kg)

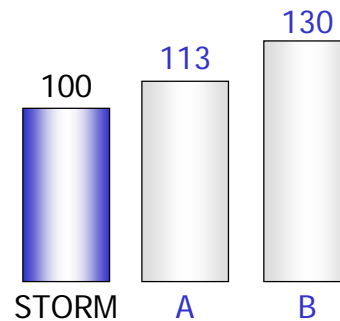

Spin Noise(dB)

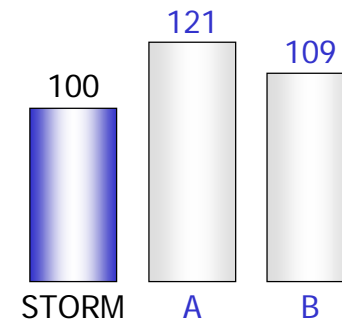

Conventional

Algorithm	<ul style="list-style-type: none"> • Hardness : 100~250 • Detergent : 1g/ • Water temp : 15~35
Actual Washing Conditions	<ul style="list-style-type: none"> • Different hardness by areas • Different detergent amount • W/temp changes by seasons
Problems	<ul style="list-style-type: none"> • Poor performances <ul style="list-style-type: none"> - H/ness, Detergent, temp • Energy overuse <ul style="list-style-type: none"> - H/ness, Detergent, temp

Hardness table for countries

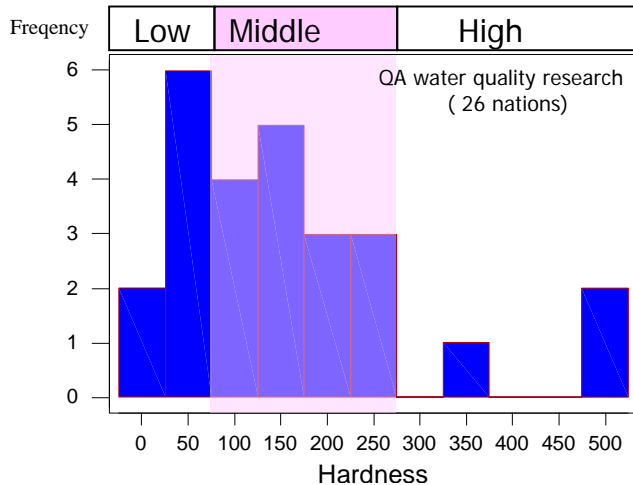

Concept

Is it impossible to make Algorithm optimized for actual washing environment in order to have performance enhanced and energy saved?

I-Sensor

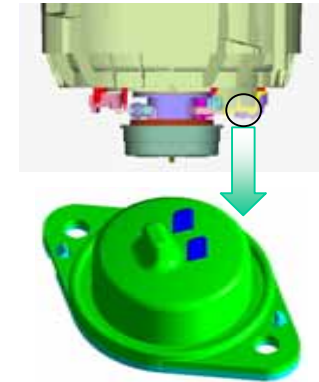

Hardness, Detergent, Water Temp. Sensing

Fuzzy Inference System

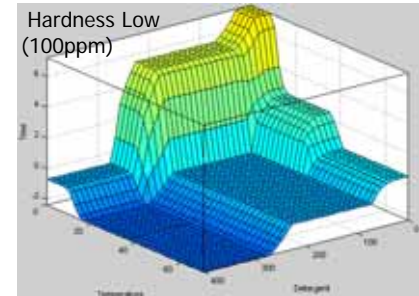

Algorithm Optimizer

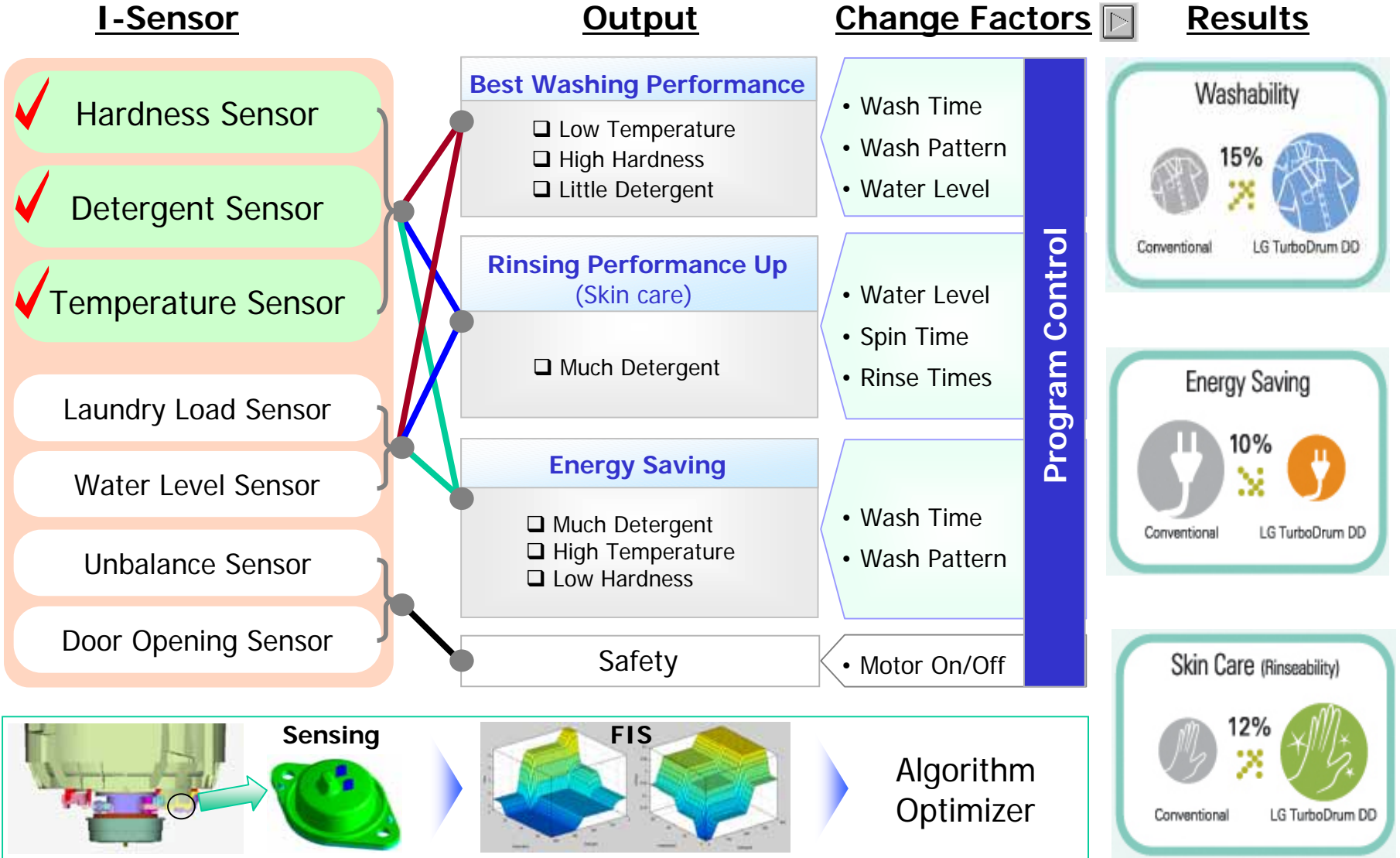

Alg. Concept

Wash

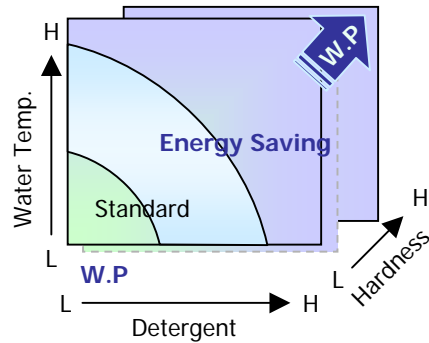

Rinse

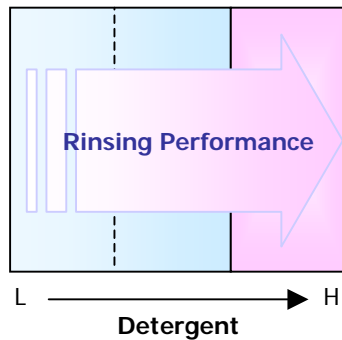

Benefit

Performance

Washing Performance

- 15% higher at ①

Energy Saving

- 10% Lower at ④

Rinsing Performance (Skin Care)

- 12% Higher at ⑨
- No Suds

Conditions

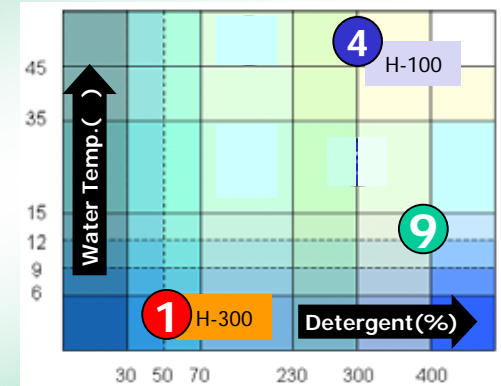

< Conventional >



< New >



Water Hardness, Detergent, and Water TemperatureAnd	LED Display	Remarks
Unfavorable wash conditions to cause more wash time & wash power	Orange	Less detergent, lower temperature, or/and higher Hardness
Standard conditions	Green	Standard conditions
Favorable wash conditions to cause less wash time & wash power	Red	More detergent, higher temperature, or/and lower hardness

USP / Smart Control & Wide Display

[Current]



[New]

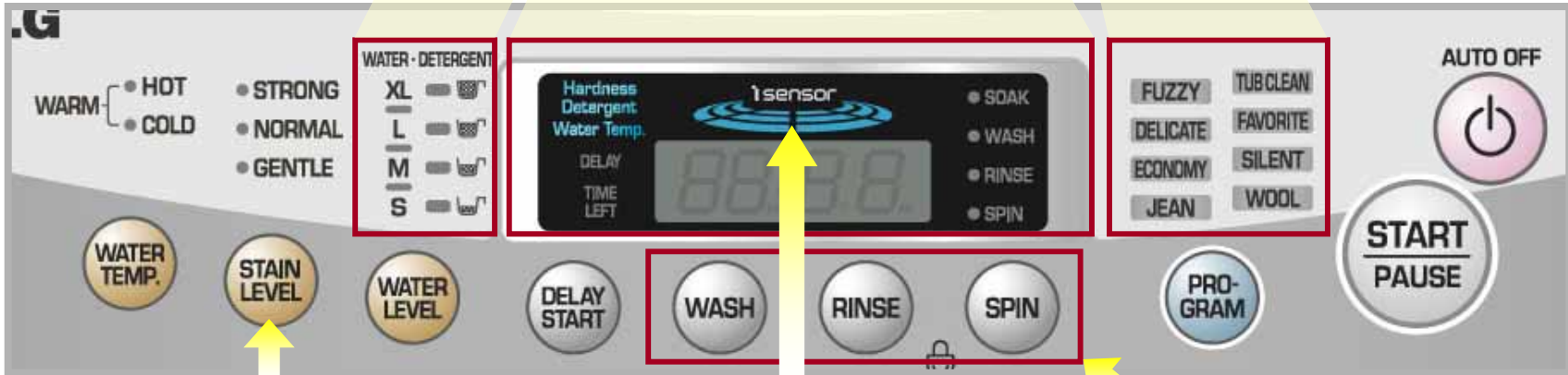

1 Multi-stage Water Level Control (4 7)

2 Wide Digital Display (88 88:88)

3 Total Care™ Programs (4 8)

4 Stain Level Options

5 Digital Display of i-Sensor™

6 Wash, Rinse, Spin Selector

Driving

O/Rotor
Induction
DD

Controller

Smart Control
&
Wide Display

Window

Design Look

Result

- 7,9,10kg Family Look
(Transparent & Opaque)
- DD Full Range Line-Up

7 kg

9 kg

10 kg

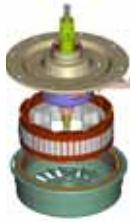

Transparent Design



Opaque Design



TurboDrum DDD™

TurboDrum Direct Drive System



3WAY WASH

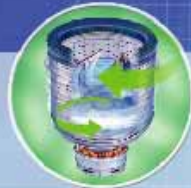

TURBODRUM wash



DRUM ROTATING wash



CENTRIFUGAL wash

INTELLIGENT WASH sensor



HARDNESS sensing



DETERGENT sensing

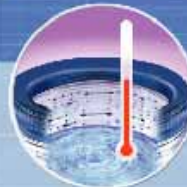

TEMPERATURE sensing



TurboDrum Direct Drive System

TurboDrum DD™

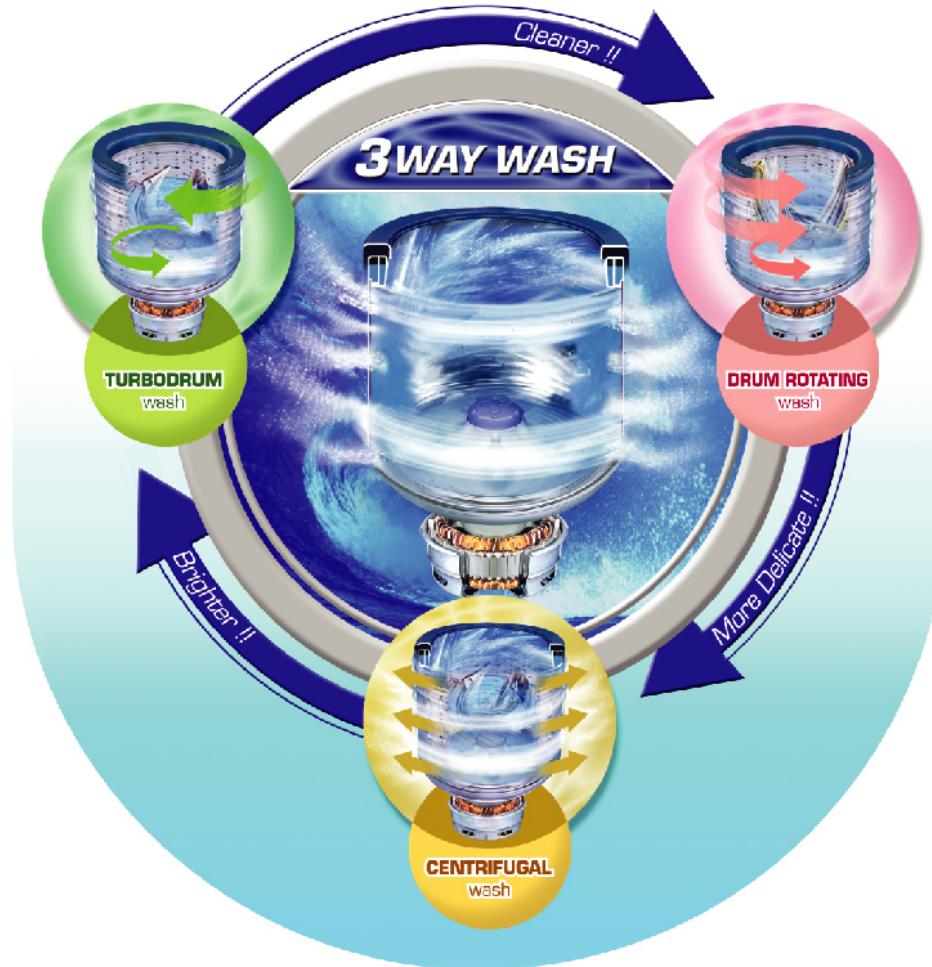

A large, curling blue wave with white foam, viewed from an underwater perspective. The water is a deep, vibrant blue, and the wave's crest is breaking into a thick, white foam. The lighting is bright, creating a shimmering effect on the water's surface.

Thank you!

I-Sensor / Sensing Principle for I-Sensor

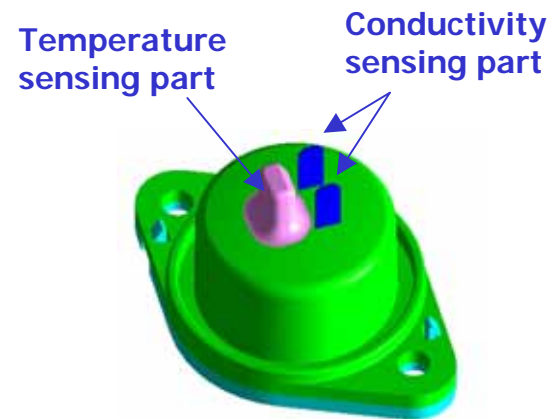
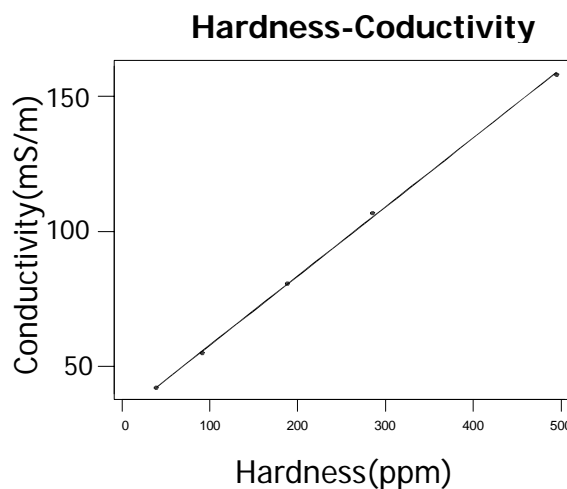
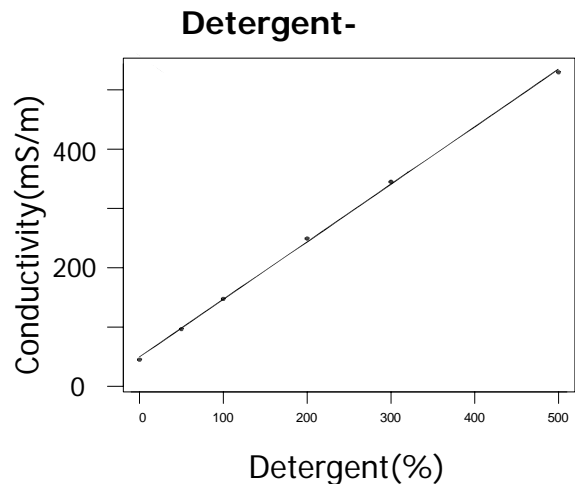
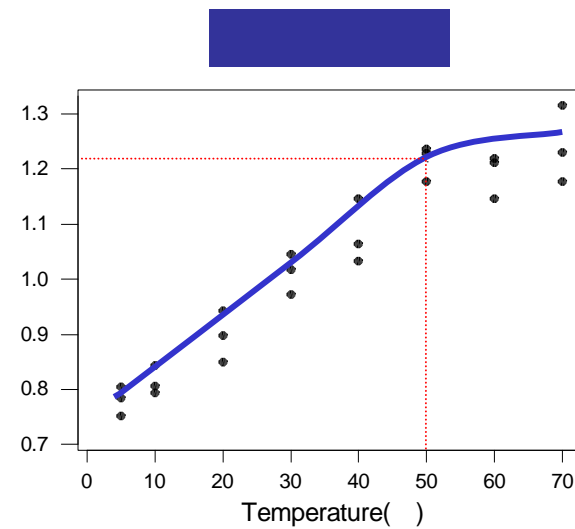
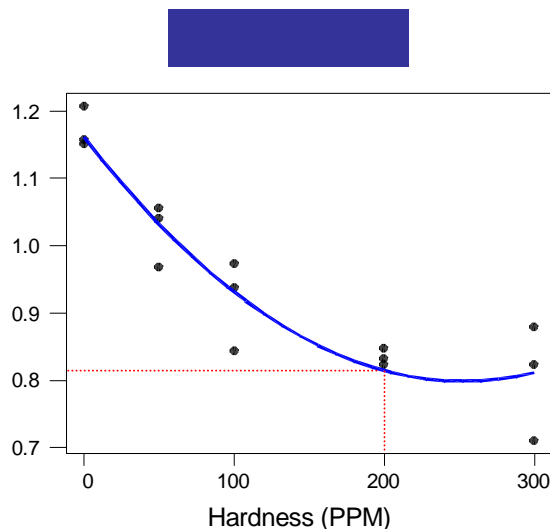
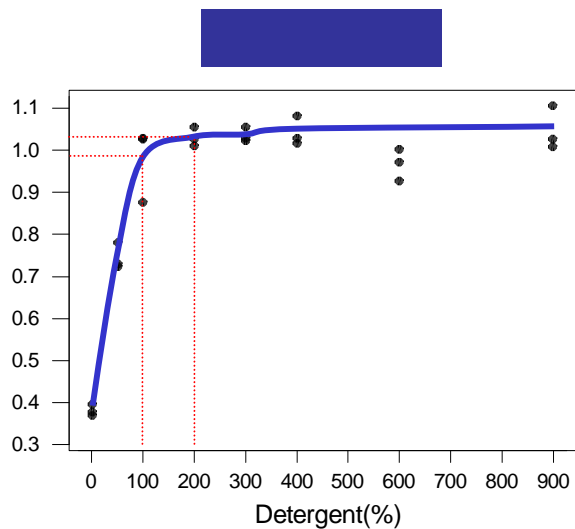

I-Sensor / Algorithm Optimization Process by F.I.S

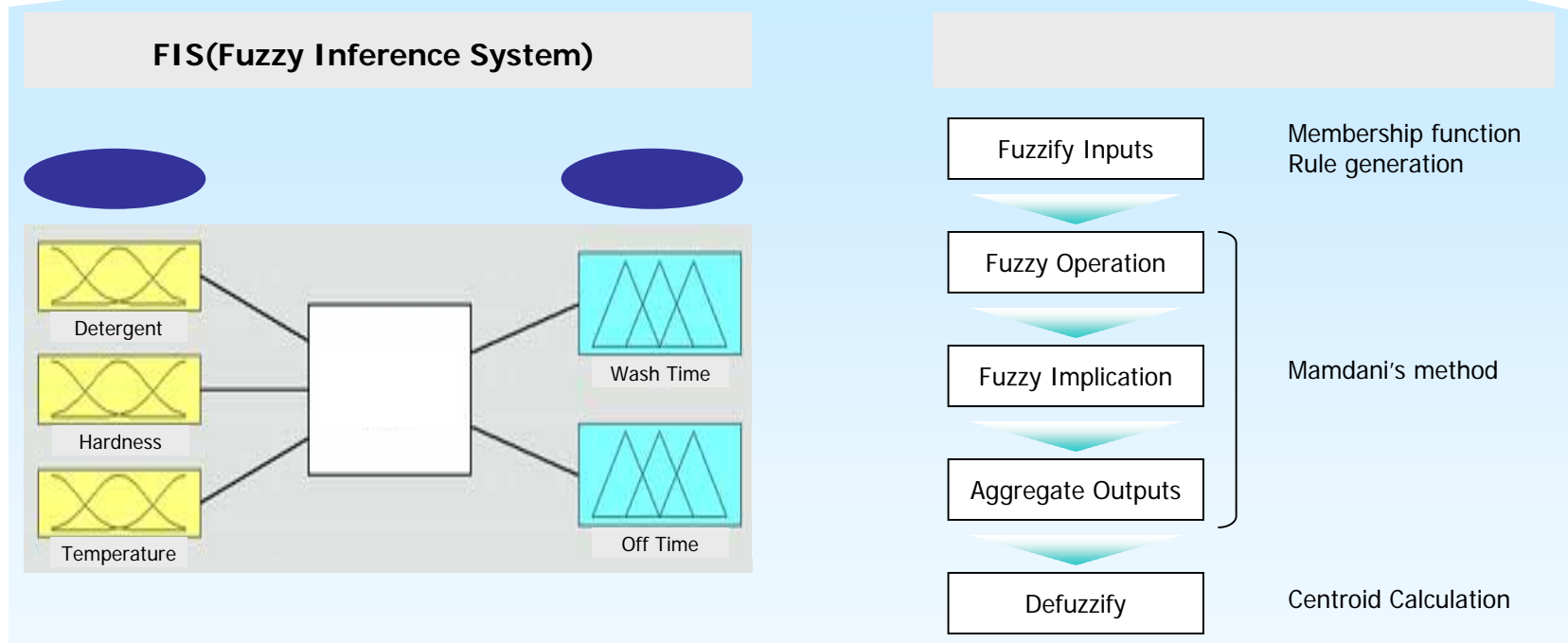

Wash Time

Hardness Low(100)

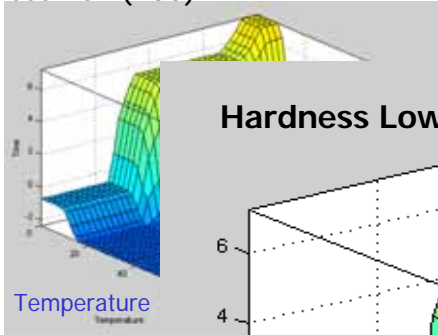

Hardness Middle(220)

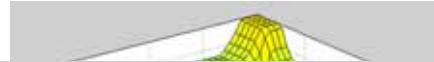

Hardness High(350)

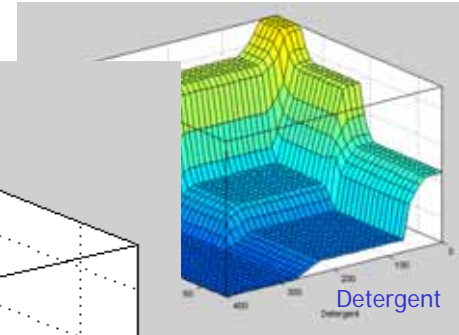

Hardness Low (100PPM)

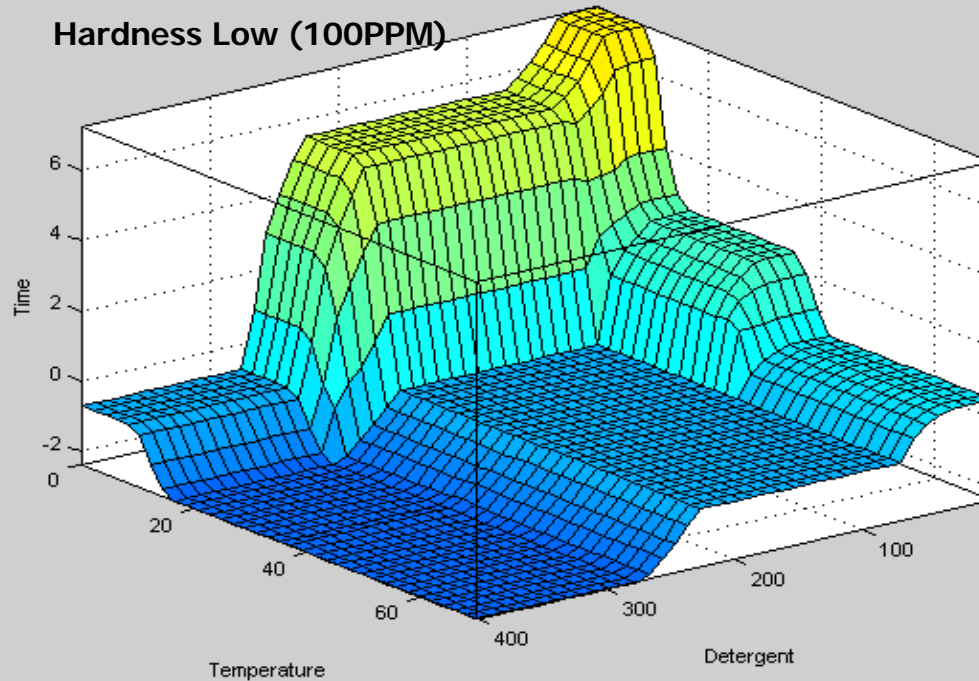

Off Time

Hardness Low(100)

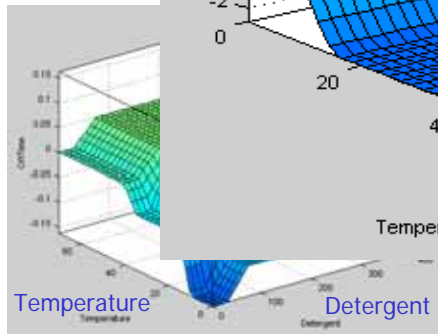

Hardness High(350)

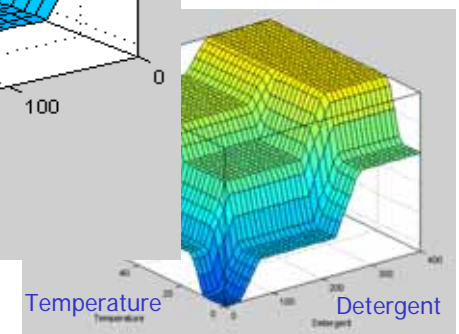

216

Wash Time

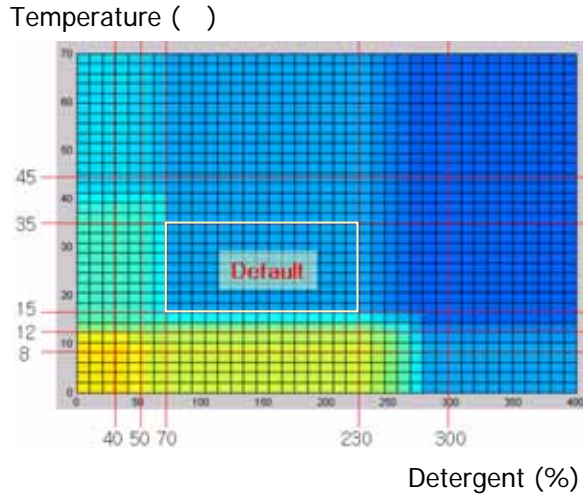

Off Time

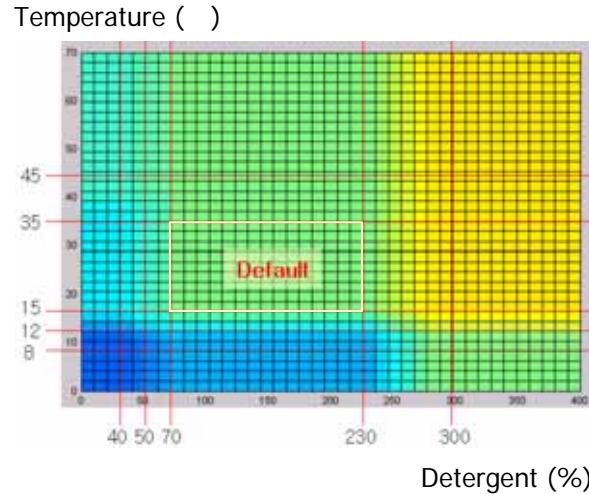

Constraints

- Wide default region
(Detergent: 70 ~ 230%, Temperature: 15 ~ 35)
- Output variables resolution
(Wash Time: 1 min., Off Time: 0.1 sec.)
- Positive off time change

: 3
: 6
: 6

Wash Time
Off Time

216

* All graphs are based on hardness 100 ppm

I-Sensor / Algorithm Control Factor



Optimize algorithm is adopted to improve the performance according to the wash condition.

Performance Target	Wash Condition	Main Factor	Change Level
Wash performance	Low Temperature High Hardness Little Detergent	Wash time	Max +8 min.
Energy saving	High Temperature Low Hardness Much Detergent	Wash time Wash pattern (Off time)	Max -2 min. Max +0.2 sec.
Skin care	Much Detergent	Spin time Rinse w. level Rinse times	Max +2 min. Max +0.2kHz <u>Deep rinse addition</u>

Transparent Lid



Opaque Lid





Turbodrum DD



Turbodrum



STORM





300

가 500

Classification of Water by Hardness Content

mg/L CaCO ₃	Degree of Hardness
0 ~ 75	(soft)
76 ~ 150	(moderately hard)
150 ~ 300	(hard)
300	(Very hard)

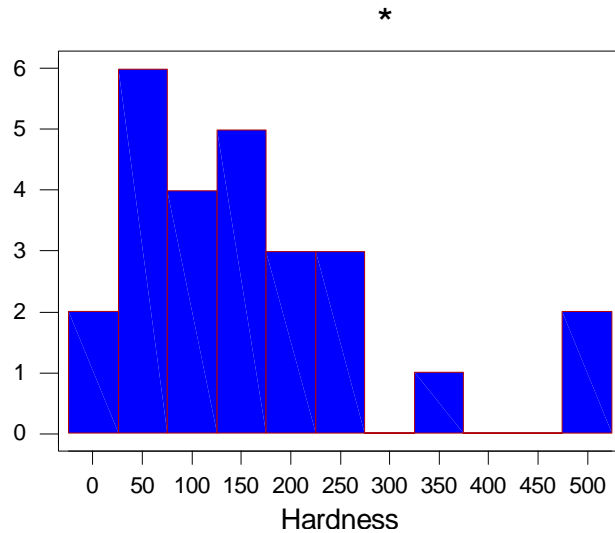

: QA

가	* (PPM)
	134
	27
	228
	174
	258
✓	22
	114
	111
	268
	514
	198
	106
	61
	175
	184
	54
	139
	515
	15
	68
	150
	366
	44
	156
	95
	50