

P2100

SERVICE MANUAL

■ FRONT PANEL

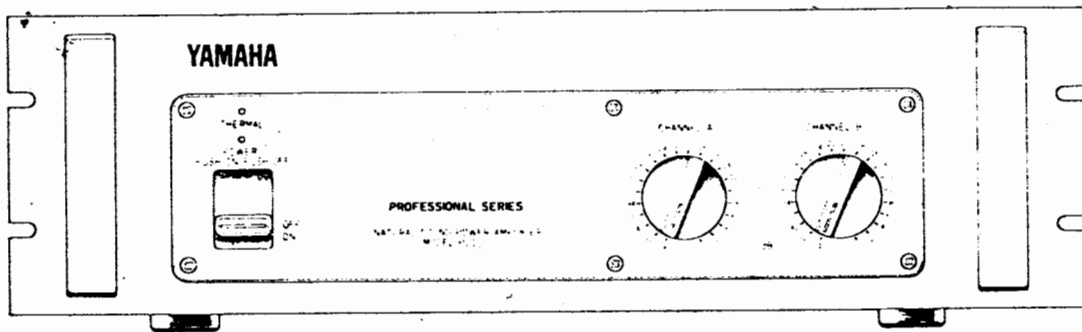

■ CONTENTS

SPECIFICATIONS	2	PRINTED CIRCUIT BOARD	5
CHARACTERISTIC CHART	2	SCHEMATIC DIAGRAM	7
PARTIAL DISASSEMBLY	3	WIRING	9
ADJUSTMENT AND INSPECTIONS ...	4	PARTS LIST	11

006368

 **YAMAHA**
Printed in Japan 4.77

SPECIFICATIONS

CIRCUIT SYSTEM ALL STAGE DIRECT COUPLED COMPLEMENTARY
PARALLEL PUSH PULL OCL CIRCUIT

POWER OUTPUT 85W + 85W (8Ω, 20Hz ~ 20KHz,
(Both channels driven) less than 0.05% THD)
140W + 140W (4Ω, 20Hz ~ 20KHz,
less than 0.05% THD)
95W + 95W (8Ω, 1KHz, less than 0.05% THD)

POWER OUTPUT AT CLIPPING 160W (4Ω, 1KHz, less than 0.05%)
(Single channel driven) 110W (8Ω, 1KHz, less than 0.05%)

FREQUENCY RESPONSE 20Hz ~ 50KHz, +0, -0.5dB

TOTAL HARMONIC DISTORTION Less than 0.02% (8Ω, @50W, 20Hz ~ 20KHz)
Less than 0.01% (8Ω, @50W, 1KHz)
Less than 0.03% (4Ω, @75W, 20Hz ~ 20KHz)
Less than 0.01% (4Ω, @75W, 1KHz)
Less than 0.05% (4Ω, @140W, 20Hz ~ 20KHz)

IM DISTORTION Less than 0.03% (75W/8Ω, 70Hz : 7KHz = 4 : 1)

INPUT SENSITIVITY 0dB ± 0.5dB (8Ω, 100W, INPUT VOLUME → MAX)

INPUT IMPEDANCE 25KΩ (UNBALANCE) INPUT VOLUME → MAX)

DAMPING FACTOR Greater than 100 (20Hz ~ 5KHz)
(4Ω load) Greater than 70 (20Hz ~ 20KHz)

OUTPUT IMPEDANCE Less than 0.04Ω (20Hz ~ 5KHz)

HUM & NOISE 110dB (20Hz ~ 20KHz)

SLEW RATE 30V/μsec (100W/8Ω, 10KHz square-wave input)

CROSS TALK 82dB, 1KHz
70dB, 20KHz

PHASE SHIFT 20Hz ~ 20KHz ± 10°

POWER REQUIREMENTS
Canadian 120V 210W
50/60 Hz 270VA
N.EUROPEAN 220/240V 700W
50/60 Hz
GENERAL 220V 700W
50/60 Hz
AUSTRALIAN 240V 700W 50/60 Hz
S.AFRICAN
BS 240V 700W 50/60 Hz
US 120V 370W
50/60 Hz 480VA

DIMENSIONS (WxHxD) 480 (19") x 140.5 (5-1/2") x 337 mm (13-1/4")

PANEL SIZE (WxH) 480 (19") x 132 mm (5-1/4")

RACK SIZE Mounts in a standard 19 inch (48cm) rack

WEIGHT 14 kg (30.9 lbs)

CHARACTERISTIC CHART

FREQUENCY RESPONSE

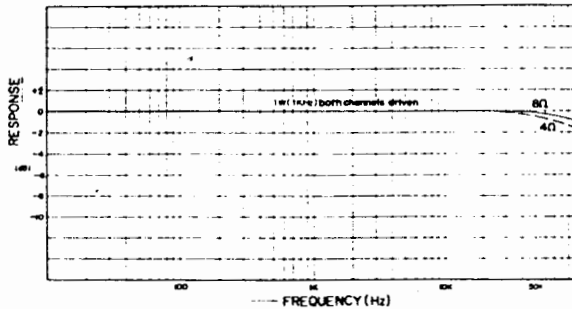

POWER BANDWIDTH

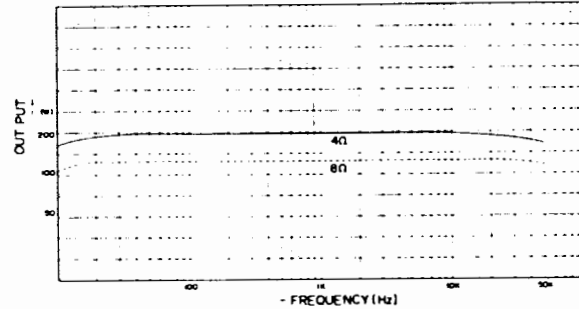

FREQUENCY : TOTAL HARMONIC DISTORTION

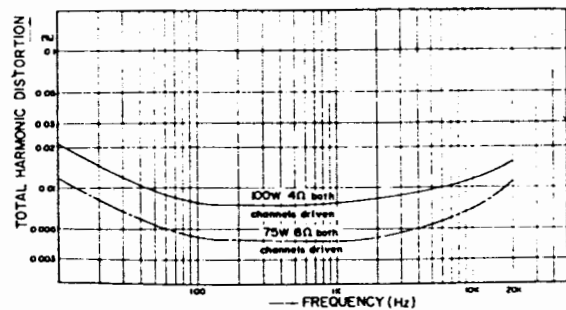

OUTPUT : TOTAL HARMONIC DISTORTION

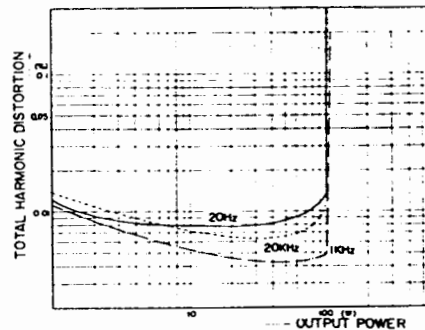

PARTIAL DISASSEMBLY

• FLOW CHART

1. Discharge the electrolytic capacitor terminals.
2. Do not mix up the lead wires connecting the printed circuit boards when removing the boards.
3. The circled numbers in the flow chart indicate the explanation numbers in the photos below.

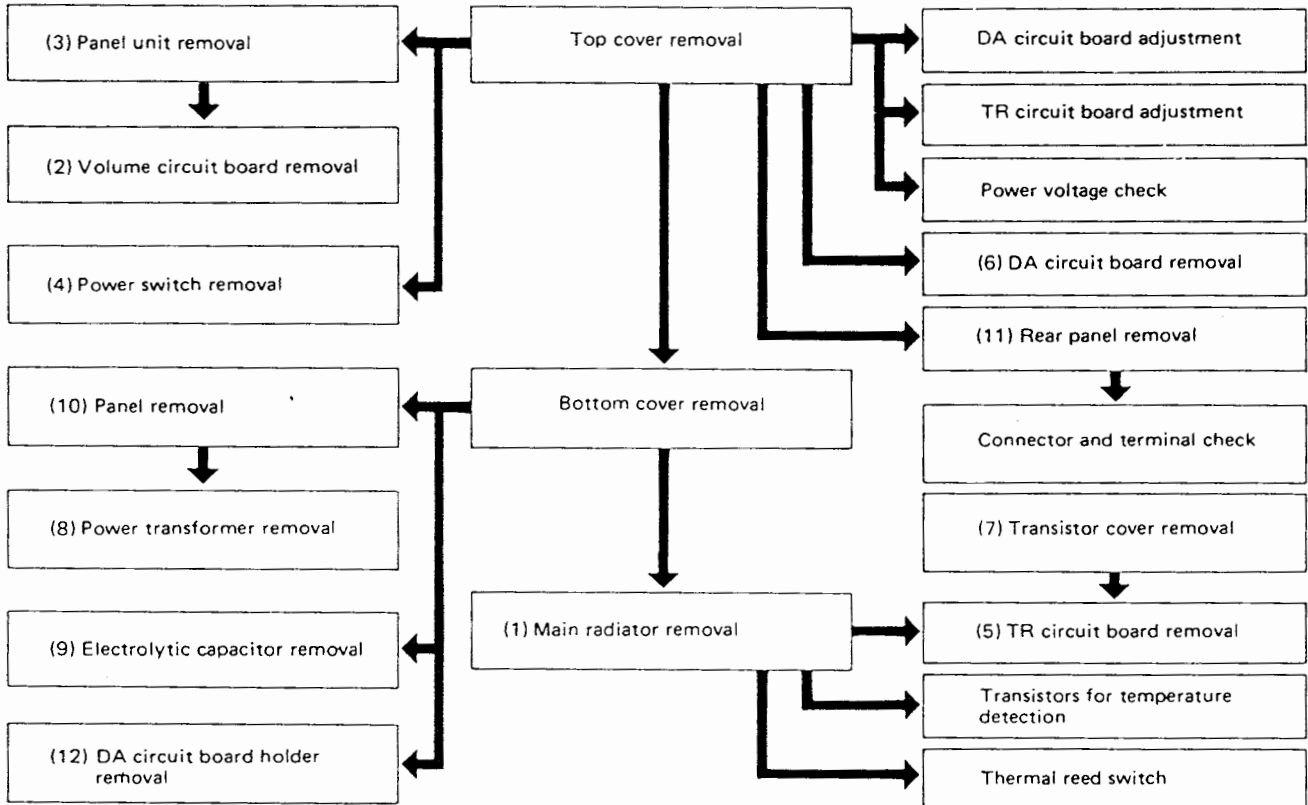

• TOP VIEW

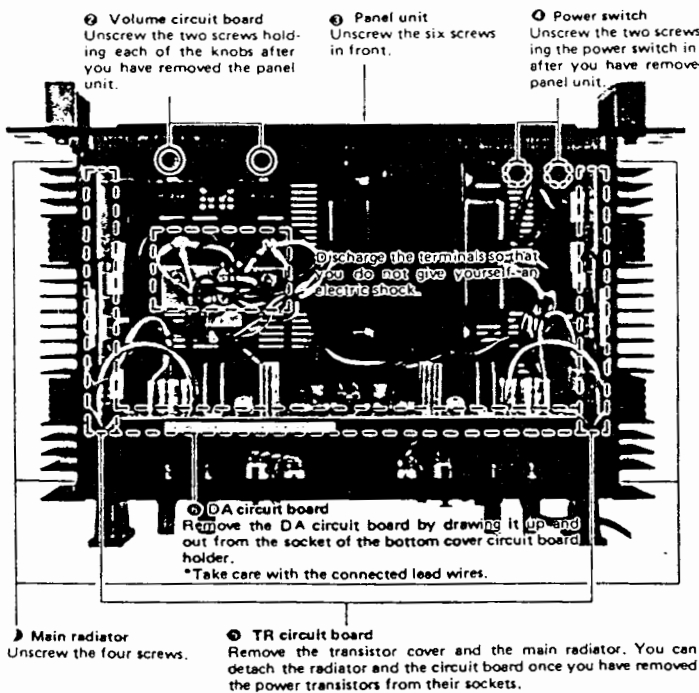

• BOTTOM VIEW

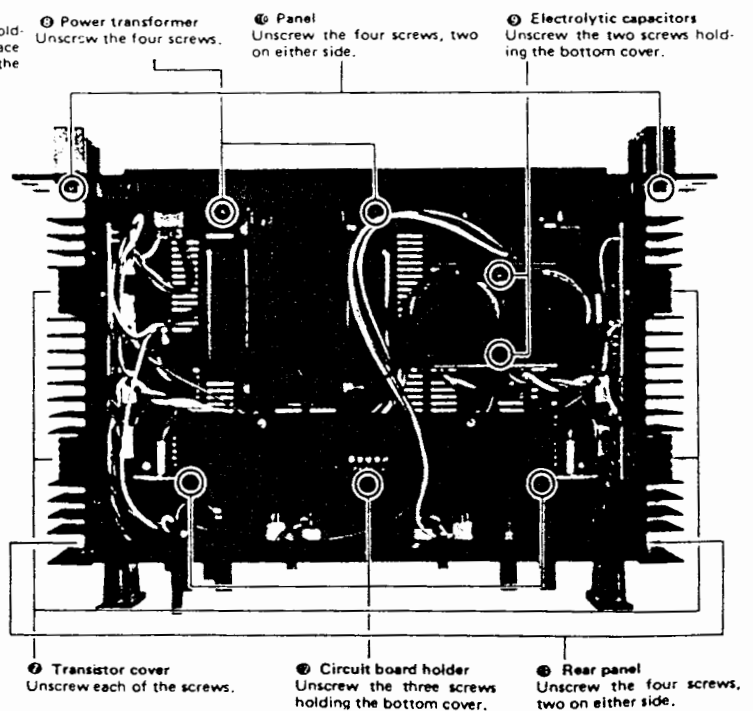

ADJUSTMENT AND INSPECTIONS

- The output impedance of the low-frequency signal generator should be less than 600Ω , and the distortion should be less than 0.005%.
- Use a syncroscope, level meter, distortion meter or other instruments with an input impedance of over $100K\Omega$.
- Discharge the electrolytic capacitors in the power rectifier circuit when the top cover has been removed.
- Turn the semi-fixed variable resistor ($1K\Omega$) on the DA circuit board to its leftmost position (min.) before switching the power on.

1. Idling current adjustment

- Switch the power on, turn the semi-fixed resistor ($1K\Omega$) on the DA circuit board so that the voltage across the TR circuit board test points PE and E is $13mV \pm 1mV$ within 30 seconds, and set. (Fig. 1)
- Perform the same adjustment for the other channel.
- The voltage across test points PE and E fluctuates with ageing (see Table 1) and so check that the voltage across these test points after the tests is $22mV \pm 5mV$ ($45mA$). (When the ambient temperature is $10^\circ C - 30^\circ C$, and the temperature of the Heat Sink is $20^\circ C - 40^\circ C$.)

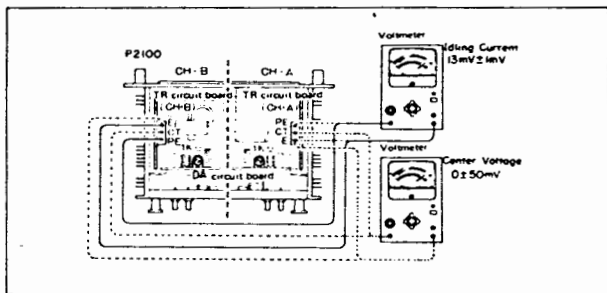

Fig. 1

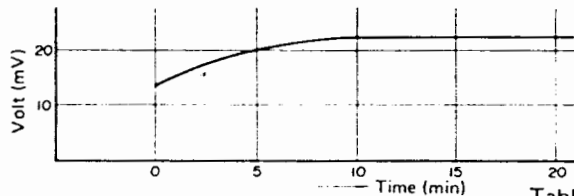

Table 1

2. Center voltage adjustment

Check that the voltage across TR circuit board CT and E terminals and across the speaker output terminals is within $0 \pm 50mV$. (Fig. 1)

3. Amplifying characteristics (stereo)

3-1. Conditions

Input terminal	XLR-3-31
Output terminal	Connect a 4Ω load impedance
Volume	Maximum
DR circuit board MONO switch	Set to stereo (ST)

3-2. Gain

- Connect the equipment as shown in Fig. 2.
- Check that the output at both ends of the load impedance is $+26.5 \pm 1dBm$ when a $-5dBm$ $1KHz$ signal is applied to the input terminal.

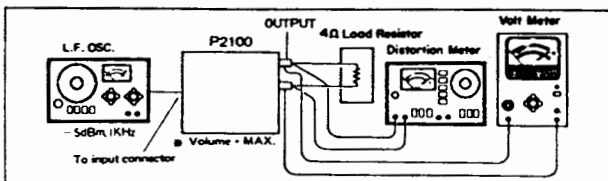

Fig. 2

3-3. Distortion

- Connections are the same as those in Fig. 2, but in addition, connect a distortion meter to the output terminals.
- Check that the distortion is less than 0.03% when $20Hz$, $1KHz$ and $20KHz$ signals are applied to the input and when an output is provided of $\approx 67W$ ($+26.5dBm$).

3-4. Frequency response

- The connections are the same as those in Fig. 2 but the waveform can be observed when a syncroscope is connected.
- Apply $10Hz$, $50KHz$ signals to the input, and based on $1KHz$ across the output terminals, check that the frequency response is within $10Hz$ $+0$ dB, -0.5 dB, $50KHz$ $+0$ dB, -0.5 dB.

3-5. maximum output

- The connections are the same as those shown in Fig. 2. In addition, connect a distortion meter to the output terminals.
- Apply $20Hz \sim 20KHz$ signals to the input and check that the $140W/4\Omega$ ($+29.7dBm$) output is provided at the output terminals at a distortion of less than 0.05%. Furthermore, connect an 8Ω resistor to the load and check that an $85W$ ($+30.5dBm$) output is obtained at a distortion of less than 0.02%. (Single channel drive for this test).

3-6. Noise level and residual noise

- The connections are the same as those in Fig. 2.
- Check that the noise level is less than $-67dBm$ when the input terminals are shorted with a 600Ω resistance.
- Check that the residual noise is less than $-70dBm$ when the volume is set to its leftmost (min.) position.

3-7. Crosstalk

Check that the output of one channel to the output terminals of the other channel is less than $-44dBm$ when a $-5dBm$, $20KHz$ signal is applied to the input terminal. Connect a 600Ω resistance to the input terminal to which the signal is not applied, and set the volume to maximum.

4. Stability

- The P2100 should operate stably even if the power voltage is fluctuated as much as $\pm 10\%$ of its specified value.
 - There should be no abnormal oscillation under the conditions listed below when the input terminals are open or shorted with a 600Ω resistance.
 - $4 - 100\Omega$ impedance load
 - $100pF - 0.47\mu F$ capacitive load
 - $10\mu H - 1H$ L load
 - Check that the overshoot is less than 0.7 under the conditions listed below with a $10KHz$ square wave signal and a $40Vp-p$ output.
 - $10\mu H - 1H$ L load
 - $100pF - 0.47\mu F$ capacitive load
- * Disassembly Procedure

PRINTED CIRCUIT BOARD 各シート図

VOL CIRCUIT BOARD : NA80250

LED CIRCUIT BOARD : NA80249^{2/3}

305400NA802493

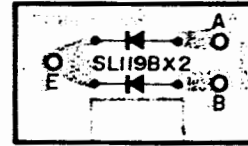
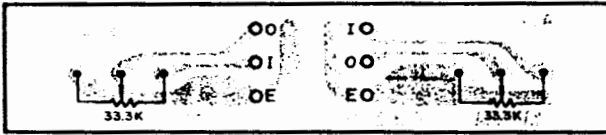

TR CIRCUIT BOARD (CHB) : NA80249^{1/3}

305400NA802491

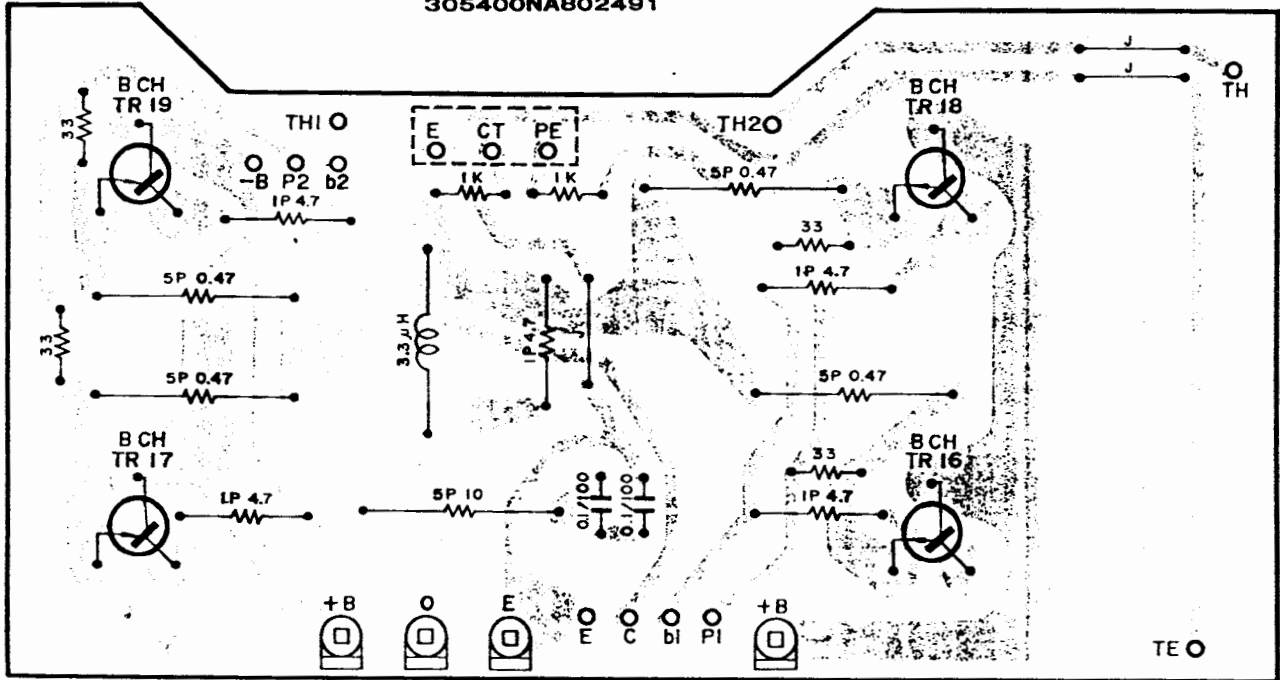

TR CIRCUIT BOARD (CHA) : NA80249^{2/3}

305400NA802492

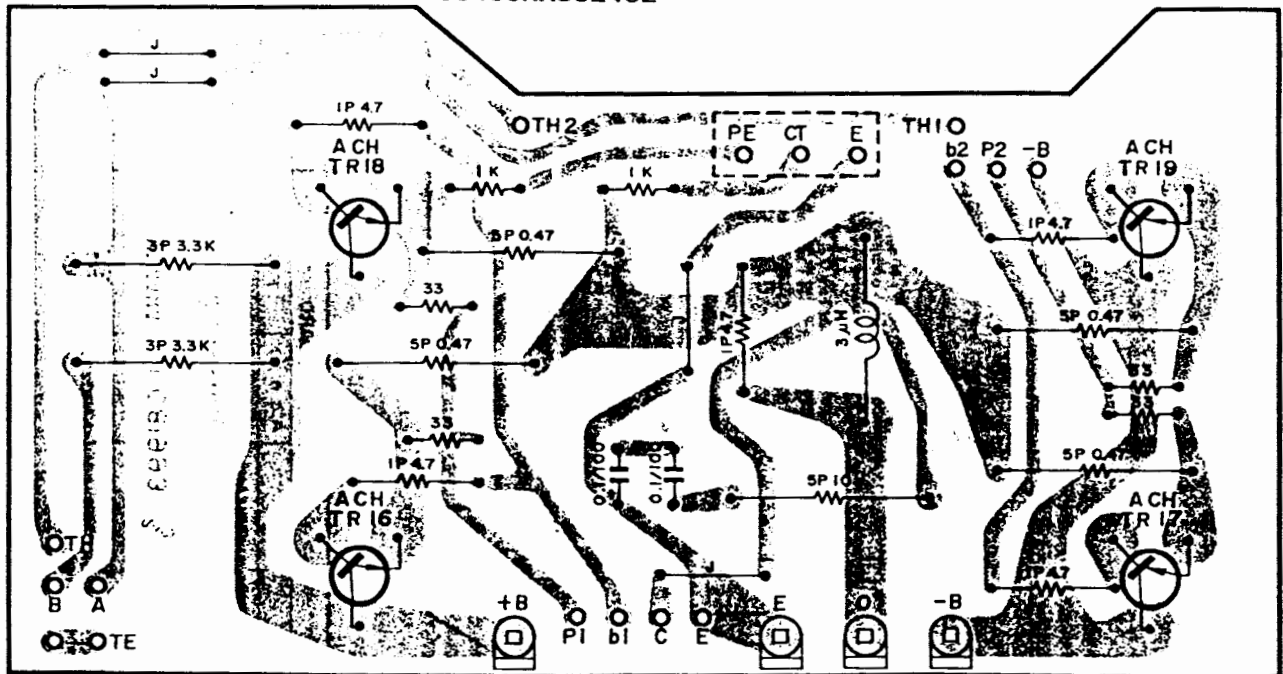

SCHEMATIC DIAGRAM 綫回路図

DA NA80251

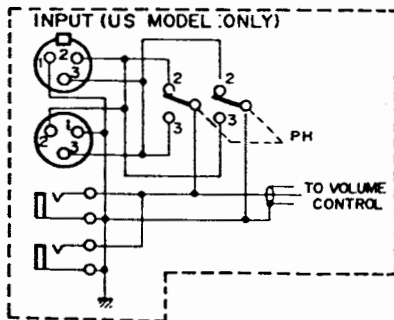
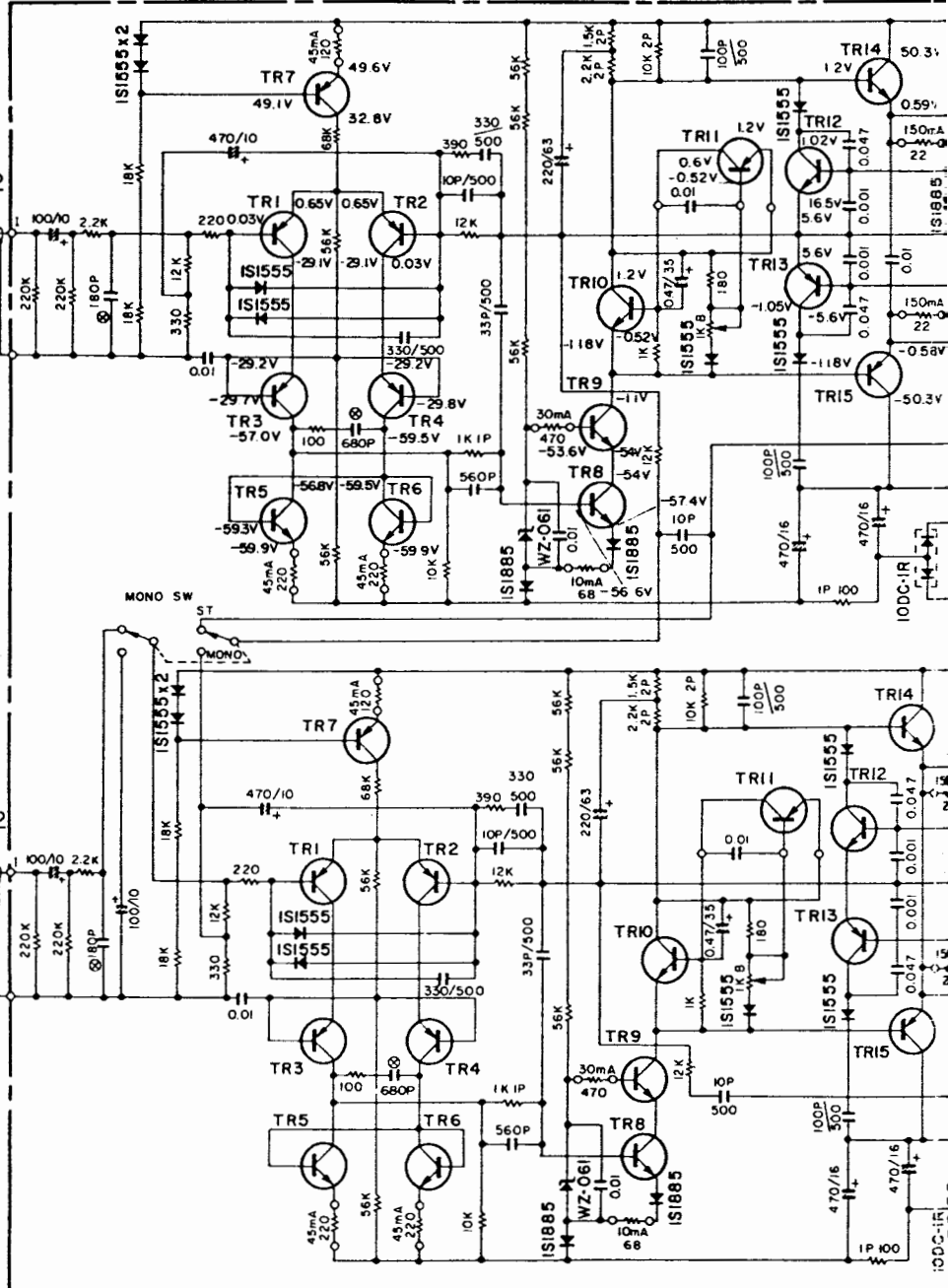
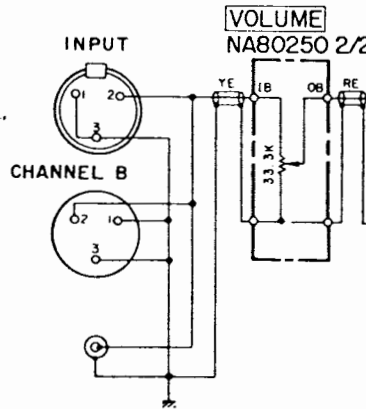
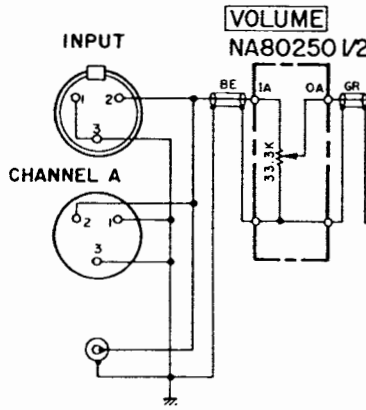

• WIRE COLOR ABBREVIATIONS

- BL ▶ Black
- BR ▶ Brown
- RE ▶ Red
- OR ▶ Orange
- YE ▶ Yellow
- GR ▶ Green
- BE ▶ Blue
- VI ▶ Violet
- GY ▶ Gray
- WH ▶ White
- GG ▶ Light Green
- SB ▶ Light Blue
- PK ▶ Pink

CAPACITOR		RESISTOR	
⊗	POLYSTYRENE	▲	FIRE PROOFING
△	TANTALUM	⊞	FUSE RESISTOR

- TR1 ~ 4
- TR5, 6, 8, 10
- TR7
- TR9, 14
- TR11
- TR13
- TR15
- TR16, 18
- TR17, 19

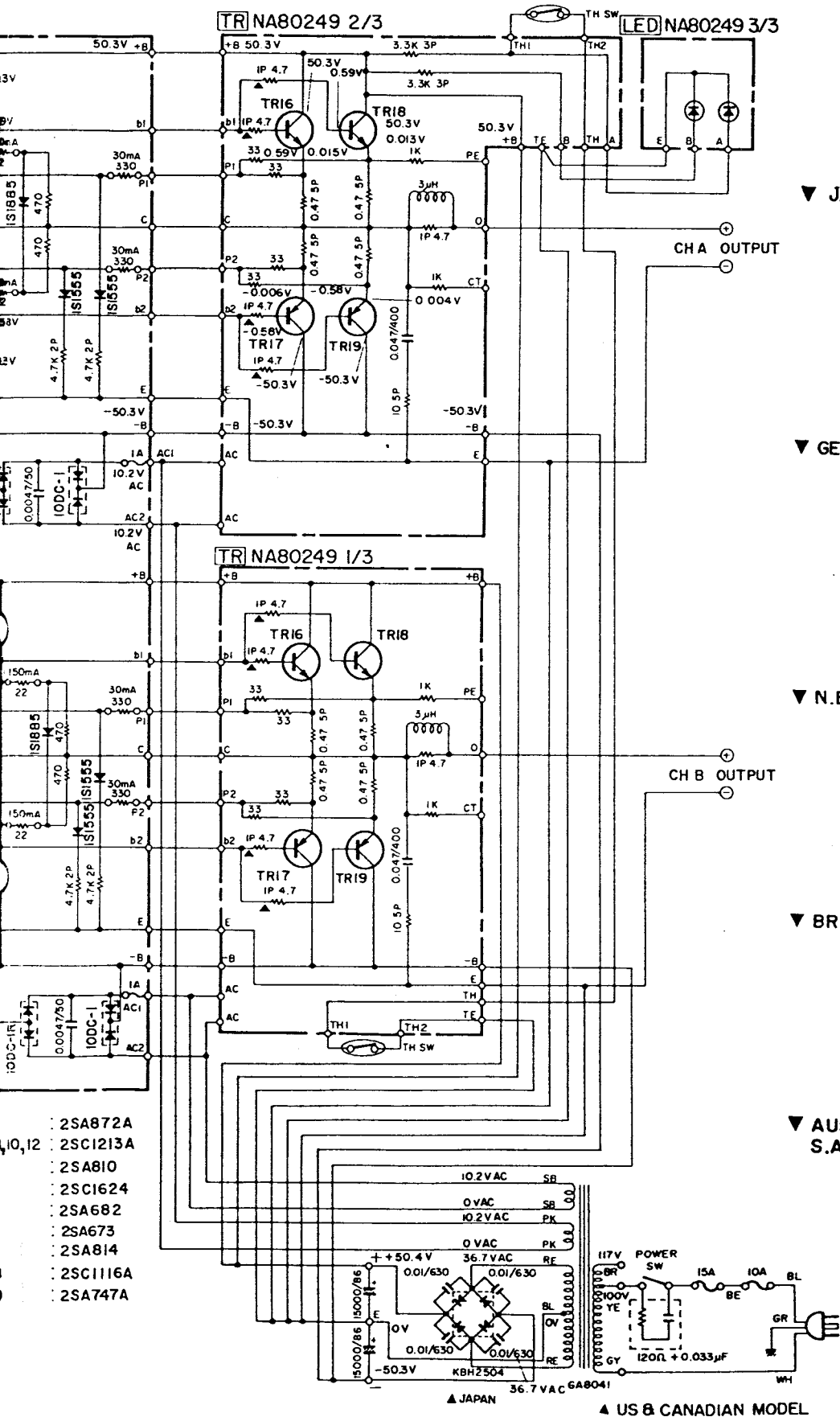

- 2SA872A
- 2SC1213A
- 2SA810
- 2SC1624
- 2SA682
- 2SA673
- 2SA814
- 2SC1116A
- 2SA747A

▲ JAPAN

▲ US & CANADIAN MODEL

▼ JAPAN MODEL

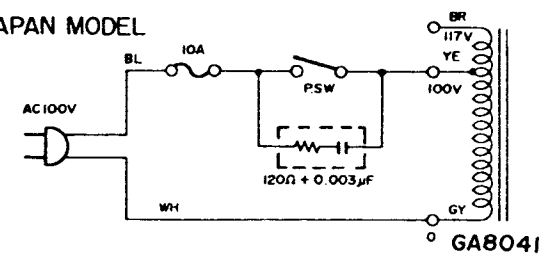

GAB041

▼ GENERAL MODEL

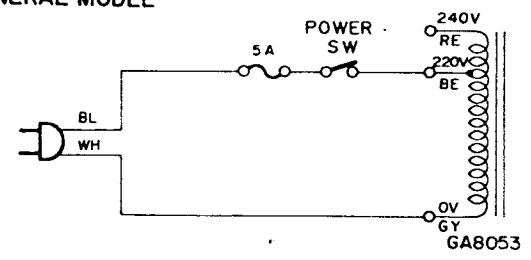

GAB053

▼ N. EUROPEAN MODEL

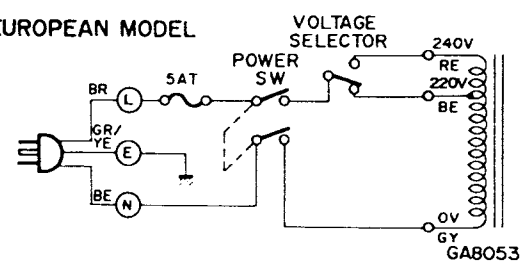

GAB053

▼ BRITISH MODEL

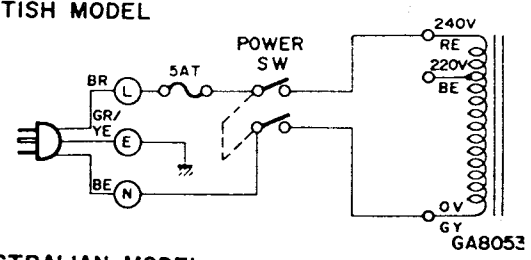

GAB053

▼ AUSTRALIAN MODEL
S.AFRICAN MODEL

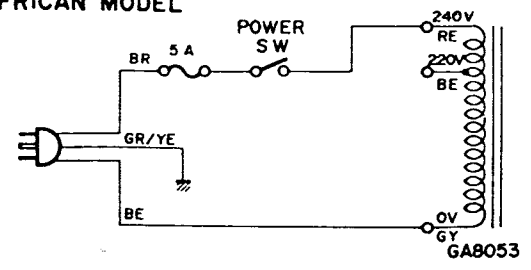

GAB053

WIRING ワイヤリング

US Model

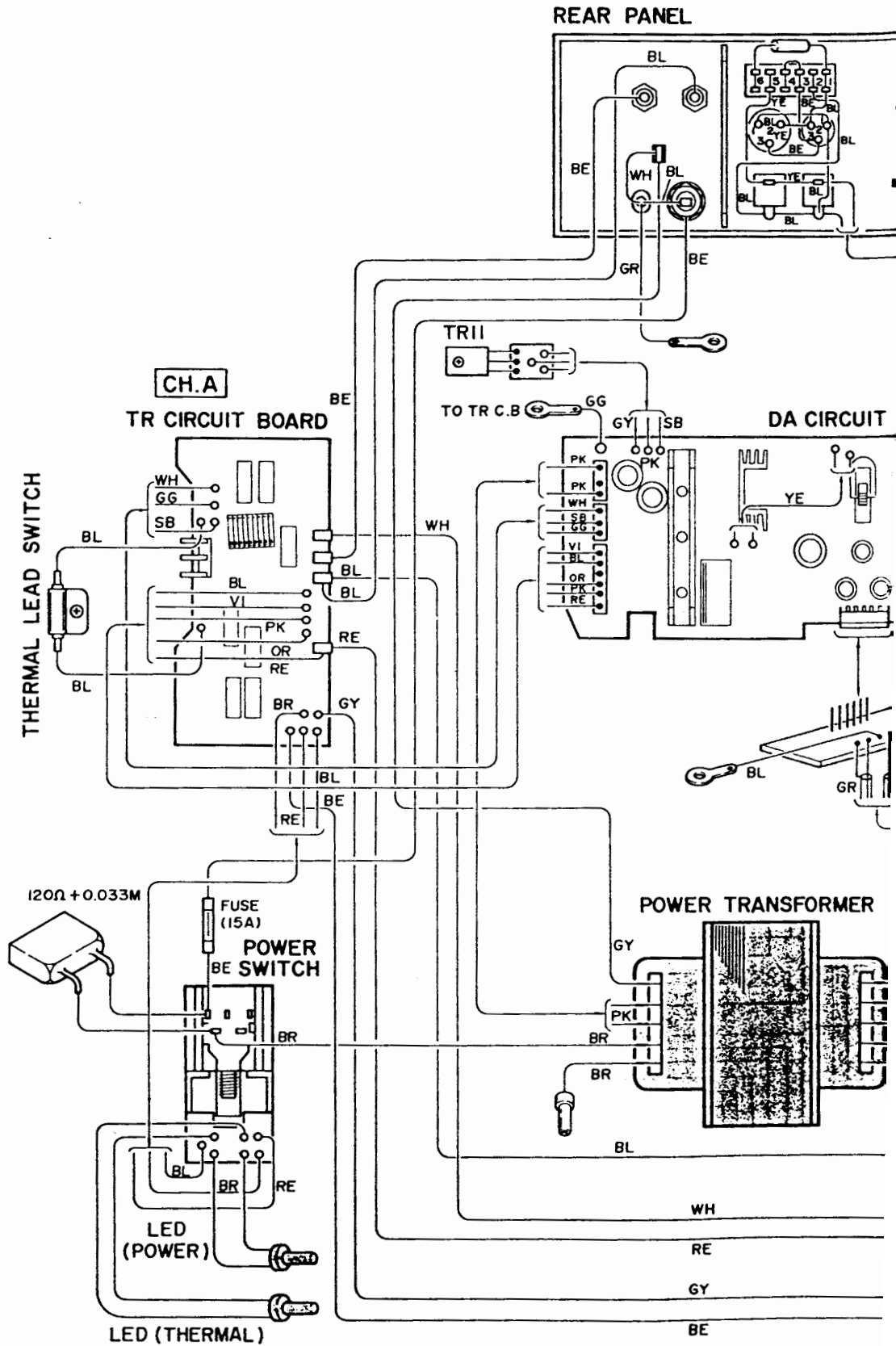

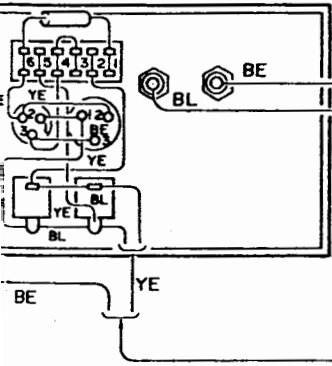

• WIRE COLOR ABBREVIATIONS

- BL ▶ Black
- BR ▶ Brown
- RE ▶ Red
- OR ▶ Orange
- YE ▶ Yellow
- GR ▶ Green
- BE ▶ Blue
- VI ▶ Violet
- GY ▶ Gray
- WH ▶ White
- GG ▶ Light Green
- SB ▶ Light Blue
- PK ▶ Pink

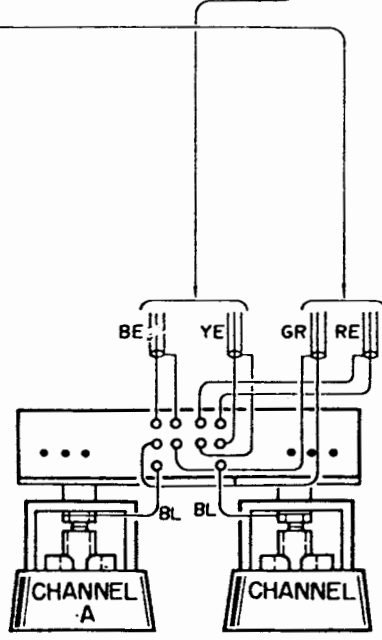
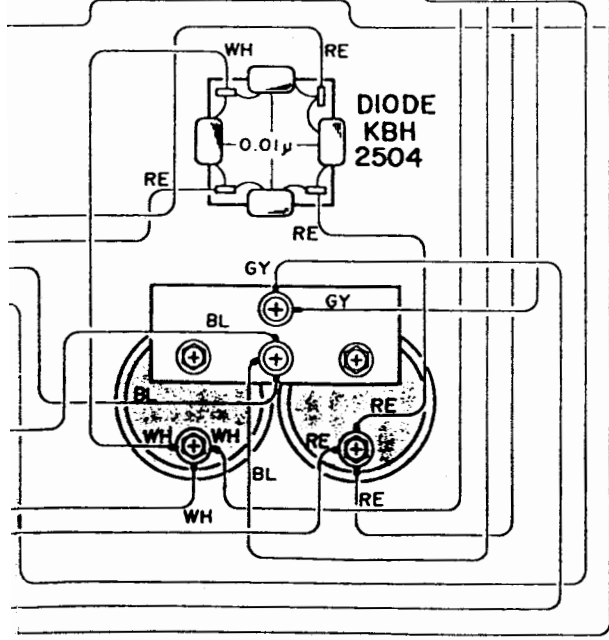
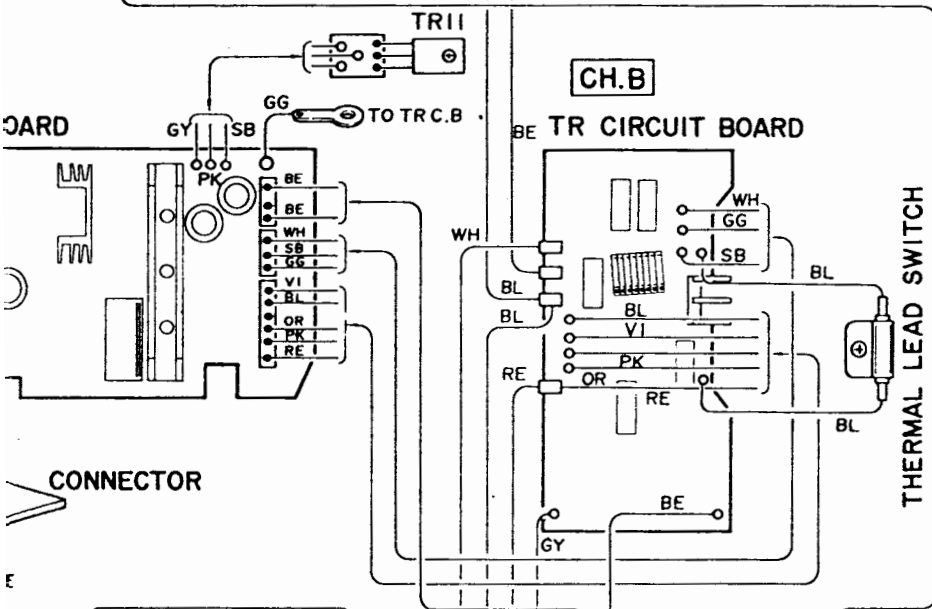

■ PARTS LIST

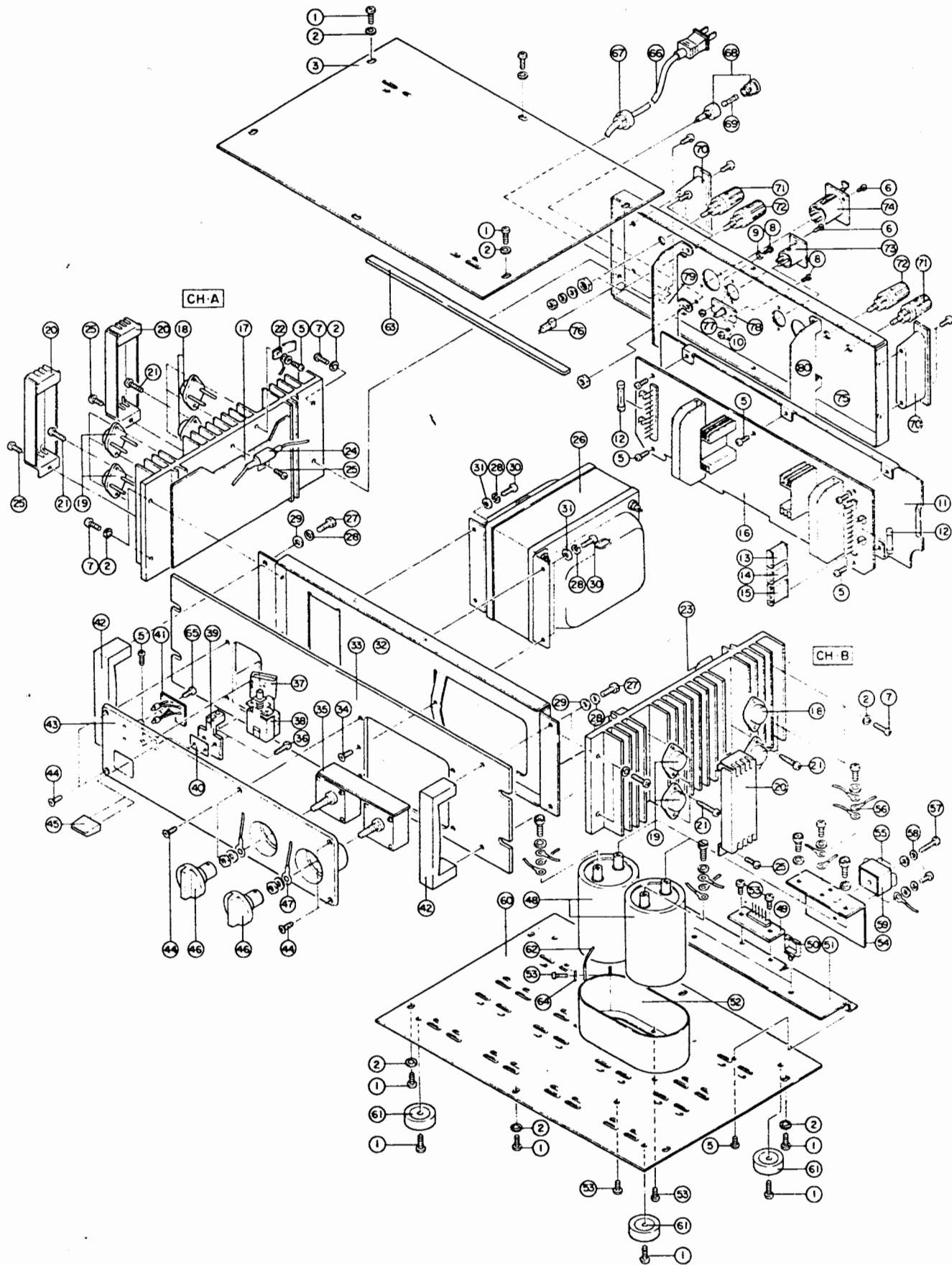

DESTINATION ABBREVIATIONS

G : General NE : North European A : Australian C : Canadian
 US : US BS : British SA : South African J : Japan

Ref. No.	Part No.	Description	Remarks
1	40 10 00 E I 44 01 20	Bind head tapping screw M4 x 12	バッキングネジ
2	40 10 00 E V 41 44 00	Toothed lock Washer A4S	歯付座金
3	30 54 00 B A 80 19 00	Top cover	トップカバー
	30 54 00 B A 80 19 10	- do. -	"
			US, C model
			J, G, SA, A, BS, NE, model
5	40 10 00 E D 03 00 50	Bind head screw M3 x 6	+ バインド小ネジ
6	40 10 00 E O 23 00 80	Oval head tapping screw M3 x 8	+ 丸皿タッピングネジ
7	40 10 00 E D 44 01 20	Bind head screw M4 x 12	+ バインド小ネジ
8	40 10 00 E D 43 00 50	Bind head screw M3 x 8	+ バインド小ネジ
9	40 10 00 E V 11 50 30	Toothed lock Washer 3S	歯付座金
10	40 10 00 E V 10 02 00	Hexagonal nut M3	六角ナット
11	30 54 00 J A A 80 45 80	Shield Platt	シールド板
12	40 10 00 K B 00 03 30	Fuse 250 V 1A	ヒューズ
	40 10 00 K B 00 10 10	- do. -	U L ヒューズ
			US model
	40 10 00 K B 00 07 30	- do. - mini 1A T, 250V	ミニヒューズ
			NE, BS model
13	30 54 00 M 7 80 29 10	Wires Ass'y (AC)	A C 線材 Ass'y
14	30 54 00 M 7 80 29 20	- do. - (-B)	- B 線材 Ass'y
15	30 54 00 M 7 80 29 30	- do. - (+B)	+ B 線材 Ass'y
16	30 54 00 N A 80 05 10	DA circuit Board	D A シート
	30 54 00 N A 80 05 20	- do. -	"
	30 54 00 N A 80 05 30	- do. -	"
			J, SA, G, C, A model
			US model
			NE, BS model
17	30 54 00 N A 80 05 40	TR circuit Board	T R シート
18	40 10 00 T P 00 02 10	Power Transistor 2SA747A	パワートランジスター
19	40 10 00 T P 00 02 20	Power Transistor 2SC 1116A	パワートランジスター
20	40 54 00 J A A 80 45 80	TR Cover	T R カバー
21	40 10 00 E A 00 00 20	Pan head Screw M2 6 x 8	+ ナベ小ネジ
22	40 10 00 T A 00 00 20	Transistor 2SA682	トランジスター
23	40 54 00 N A 80 05 30	TR Circuit Board	T R シート
24	40 10 00 K A 80 02 20	Thermal lead Relay	サーマルリードリレー
25	40 10 00 E I 43 01 50	Bind head Tapping screw M3 x 8	+ バインドタッピングネジ
26	40 10 00 S A 80 19 50	Power Transformer	パワートランス
	40 10 00 S A 80 19 50	- do. -	"
			J, US, C model
			G, SA, A, BS, NE model
27	40 10 00 E V 41 44 00	Hexagonal screw M5 x 15	六角ボルト
28	40 10 00 E V 41 44 00	Spring lock washer 5φ	バネ座金
29	40 10 00 E V 41 44 00	Flat Washer 5S	平座金
30	40 10 00 E D 03 01 50	Bind head screw M5 x 15	+ バインド小ネジ
31	40 10 00 E V 41 44 00	Flat Washer 5S	平座金
32	40 54 00 J A A 80 45 80	Sub Panel	サブパネル
33	40 54 00 B A 80 19 50	Panel	パネル
34	40 10 00 E B 04 01 00	Flat head screw M4 x 10	+ 皿小ネジ
35	30 54 00 N A 80 25 30	VOL circuit Board	V O L シート
36	40 10 00 E I 43 01 50	Bind head tapping screw M3 x 16	バッキングネジ
37	40 10 00 F 2 00 01 10	Spark killer 0.33 μF 120Ω	スパークキラー
38	40 10 00 K A 80 02 20	Push Switch 125V 10A	プッシュスイッチ
	40 10 00 K A 80 02 10	- do. -	"
			J, G, SA model
	40 10 00 K A 80 02 00	- do. -	"
			A, BS, NE model
			US, C model
39	30 54 00 C B 80 66 80	Slider for Push Switch	パワースイッチスライダ
40	40 10 00 C B 80 67 10	Tape (Red) for Power Indicator	インジケータテープ
41	40 10 00 N A 80 24 00	LED circuit Board	L E D シート
42	30 54 00 B A 80 19 50	Handle for Front panel	アンプハンドル

• General, Canadian, Australian, S.African Models

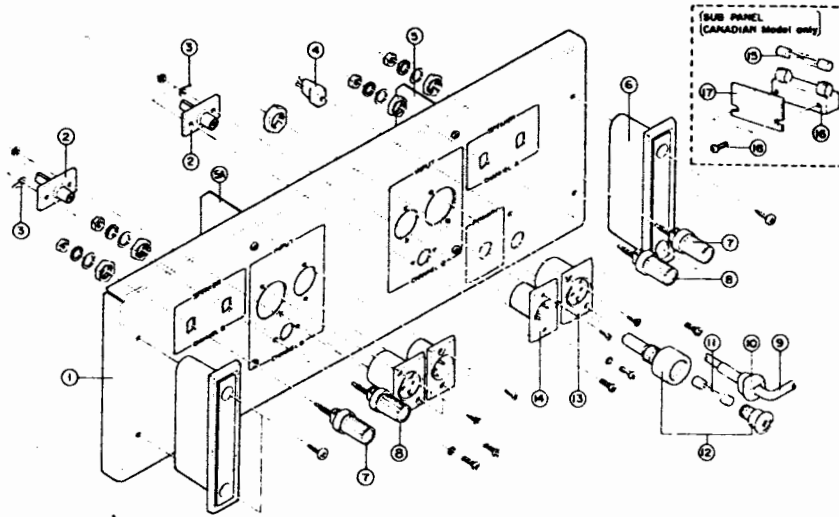

• US Model

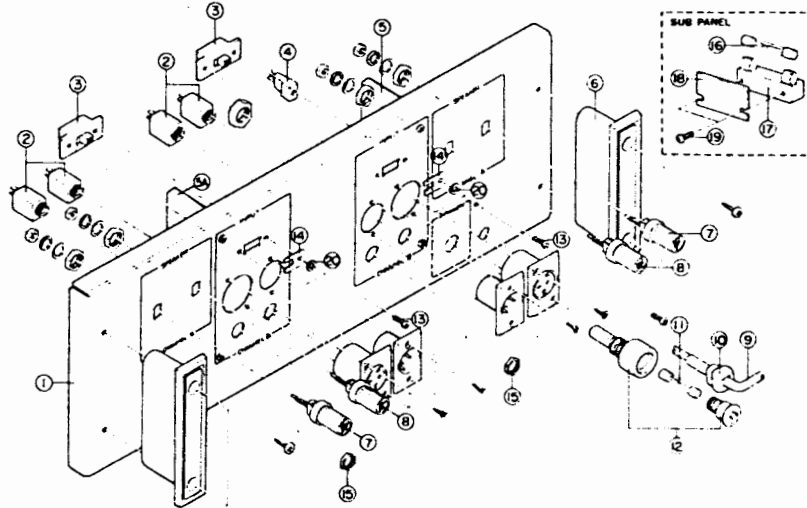

• North European, B.S Models

