

# Service Manual

## Multi Air Conditioner

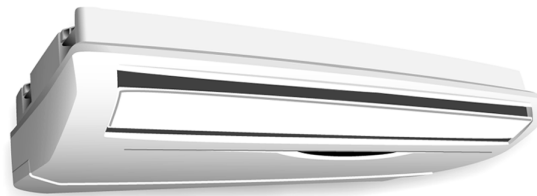

### INDOOR UNIT

CS-ME7DKEG CS-ME10DD3EW  
CS-ME10DTEG CS-E15DB4EW  
CS-ME7DKDG CS-E9DKDW  
CS-E9DKEW CS-E12DKDW  
CS-E12DKEW CS-E15DKDW  
CS-E15DKEW CS-E18DKDW  
CS-E18DKEW CS-E15DTEW  
CS-E18DTEW CS-E15DD3EW  
CS-E18DD3EW CS-E18DB4EW

### OUTDOOR UNIT

CU-3E18EBE

#### WARNING

This service information is designed for experienced repair technicians only and is not designed for use by the general public. It does not contain warnings or cautions to advise non-technical individuals of potential dangers in attempting to service a product. Products powered by electricity should be serviced or repaired only by experienced professional technicians. Any attempt to service or repair the product or products dealt with in this service information by anyone else could result in serious injury or death.

#### PRECAUTION OF LOW TEMPERATURE

In order to avoid frostbite, be assured of no refrigerant leakage during the installation or repairing of refrigeration circuit.

# Panasonic®

© 2006 Matsushita Electric Industrial Co., Ltd. All rights reserved. Unauthorized copying and distribution is a violation of law.

# CONTENTS

	Page		Page
<b>1 Safety Precautions</b> .....	<b>3</b>	8.2. Duct Type .....	53
<b>2 Features</b> .....	<b>5</b>	8.3. Ceiling Floor Type .....	59
2.1. Wall Type .....	6	8.4. Mini-Cassette Type .....	73
2.2. Duct Type .....	9	8.5. Outdoor Unit Operation .....	87
2.3. Ceiling Floor Type .....	12	8.6. Forced Cooling Operation Control .....	88
2.4. Mini-Cassette Type .....	14	8.7. Wiring Error Check Control .....	89
<b>3 Product Specifications</b> .....	<b>16</b>	8.8. Outdoor Unit - Check Point .....	90
3.1. Wall Type .....	16	<b>9 Self Diagnosis Display</b> .....	<b>91</b>
3.2. Duct Type .....	17	9.1. Breakdown Self Diagnosis Function (Three Digits Alphanumeric Code) .....	91
3.3. Ceiling Floor Type .....	18	9.2. Error Code .....	92
3.4. Mini-Cassette Type .....	19	<b>10 Installation Information</b> .....	<b>96</b>
3.5. Outdoor unit: CU-3E18EBE .....	20	<b>11 Installation Instructions</b> .....	<b>97</b>
<b>4 Dimensions</b> .....	<b>21</b>	<b>12 Disassembly of Parts</b> .....	<b>108</b>
4.1. Wall Type .....	21	12.1. Wall Type .....	108
4.2. Duct Type .....	23	12.2. Duct Type .....	110
4.3. Ceiling Floor Type .....	25	12.3. Ceiling Floor Type .....	112
4.4. Mini-Cassette Type .....	26	12.4. Mini-Cassette Type .....	113
4.5. Outdoor Unit .....	27	12.5. Outdoor Unit .....	115
<b>5 Refrigeration Cycle Diagram</b> .....	<b>28</b>	<b>13 Technical Data</b> .....	<b>117</b>
<b>6 Wiring Diagram</b> .....	<b>29</b>	13.1. Operation Characteristics .....	117
6.1. Wall Type .....	29	<b>14 Exploded View and Replacement Parts List</b> .....	<b>119</b>
6.2. Duct Type .....	30	14.1. Wall Type .....	119
6.3. Ceiling Floor Type .....	31	14.2. Duct Type .....	125
6.4. Mini-Cassette Type .....	32	14.3. Ceiling Floor Type .....	127
6.5. Outdoor Unit .....	33	14.4. Mini-Cassette Type .....	129
<b>7 Electronic Circuit Diagram</b> .....	<b>34</b>	14.5. Outdoor Unit .....	134
<b>8 Operation Details</b> .....	<b>36</b>		
8.1. Wall Type .....	36		

# 1 Safety Precautions

- Read the following “SAFETY PRECAUTIONS” carefully before perform any servicing.
- Electrical work must be installed or serviced by a licensed electrician. Be sure to use the correct rating of the power plug and main circuit for the model installed.
- The caution items stated here must be followed because these important contents are related to safety. The meaning of each indication used is as below.  
 Incorrect installation or servicing due to ignoring of the instruction will cause harm or damage, and the seriousness is classified by the following indications.





	<b>WARNING</b>	This indication shows the possibility of causing death or serious injury.
---	----------------	---



	<b>CAUTION</b>	This indication shows the possibility of causing injury or damage to properties.
---	----------------	--

The items to be followed are classified by the symbols:

	This symbol denotes item that is PROHIBITED from doing.
---	---

- Carry out test running to confirm that no abnormality occurs after the servicing. Then, explain to user the operation, care and maintenance as stated in instructions. Please remind the customer to keep the operating instructions for future reference.

 <b>WARNING</b>	
1. Engage dealer or specialist for installation and servicing. If installation or servicing done by the user is defective, it will cause water leakage, electrical shock or fire.	
2. Install according to this installation instructions strictly. If installation is defective, it will cause water leakage, electrical shock or fire.	
3. Use the attached accessories parts and specified parts for installation and servicing. Otherwise, it will cause the set to fall, water leakage, fire or electrical shock.	
4. Install at a strong and firm location which is able to withstand the set’s weight. If the strength is not enough or installation is not properly done, the set will drop and cause injury.	
5. For electrical work, follow the local national wiring standard, regulation and the installation instruction. An independent circuit and single outlet must be used. If electrical circuit capacity is not enough or defect found in electrical work, it will cause electrical shock or fire.	
6. Use the specified cable and connect tightly for indoor/outdoor connection. Connect tightly and clamp the cable so that no external force will be acted on the terminal. If connection or fixing is not perfect, it will cause heat-up or fire at the connection.	
7. Wire routing must be properly arranged so that control board cover is fixed properly. If control board cover is not fixed perfectly, it will cause heat-up at connection point of terminal, fire or electrical shock.	
8. When connecting the piping, do not allow air or any substances other than the specified refrigerant to enter the refrigeration cycle. Otherwise, this may lower the capacity, cause abnormally high pressure in the refrigeration cycle, and possibly result in explosion and injury.	
9. Thickness of copper pipes used must be more than 0.8 mm. Never use copper pipes thinner than 0.8 mm.	
10. It is desirable that the amount of residual oil is less than 40 mg/10 m.	
11. Do not modify the length of the power supply cord or use of the extension cord, and do not share the single outlet with other electrical appliances. Otherwise, it will cause fire or electrical shock.	

 <b>CAUTION</b>	
1. The equipment must be earthed. It may cause electrical shock if grounding is not perfect.	
2. Do not install the unit at place where leakage of flammable gas may occur. In case gas leaks and accumulates at surrounding of the unit, it may cause fire.	
3. Carry out drainage piping as mentioned in installation instructions. If drainage is not perfect, water may enter the room and damage the furniture.	



## CAUTION

4. Pb free solder has a higher melting point than standard solder; typically the melting point is 50 - 70°F (30 - 40°C) higher. Please use a high temperature soldering iron. In case of the soldering iron with temperature control, please set it to 700 20°F (370 10°C). Pb free solder will tend to splash when heated too high (about 1100°F/600°C).

## ATTENTION

1. Selection of the installation location. Select an installation location which is rigid and strong enough to support or hold the unit, and select a location for easy maintenance.
2. Power supply connection to the conditioner. Connect the power supply cord of the air conditioner to the mains using one of the following methods. Power supply point shall be the place where there is ease for access for the power disconnection in case of emergency. In some countries, permanent connection of this room air conditioner to the power supply is prohibited.
  1. Power supply connection to the receptacle using a power plug. Use an approved power plug with earth pin for the connection to the socket.
  2. Power supply connection to a circuit breaker for the permanent connection. Use an approved circuit breaker for the permanent connection. It must be a double pole switch with a minimum 3.5 mm contact gap.
3. Do not release refrigerant during piping work for installation, servicing reinstallation and during repairing a refrigeration parts. Take care of the liquid refrigerant, it may cause frostbite.
4. Installation work. It may need two people to carry out the installation work.
5. Do not install this appliance in a laundry room or other location where water may drip from the ceiling, etc.

## 2 Features

### • Product

- A single OUTDOOR unit enable air conditioning of up to three separate rooms for CU-3E18EBE.

CONNECTABLE INDOOR UNIT			OUTDOOR UNIT		
			CU-3E18EBE		
Type	ROOM		A	B	C
Wall	2.2kW	CS-ME7DKDG	⊙	⊙	⊙
		CS-ME7DKEG	⊙	⊙	⊙
	2.8kW	CS-E9DKDW	⊙	⊙	⊙
		CS-E9DKEW	⊙	⊙	⊙
	3.2kW	CS-E12DKDW	⊙	⊙	⊙
		CS-E12DKEW	⊙	⊙	⊙
	4.0kW	CS-E15DKDW	⊙	⊙	⊙
		CS-E15DKEW	⊙	⊙	⊙
5.0kW	CS-E18DKDW	⊙	⊙	⊙	
	CS-E18DKEW	⊙	⊙	⊙	
Duct	2.8kW	CS-ME10DD3EG	⊙	⊙	⊙
	4.0kW	CS-ME15DD3EG	⊙	⊙	⊙
	5.0kW	CS-ME18DD3EG	⊙	⊙	⊙
Ceiling Floor	2.8kW	CS-ME10DTEG	⊙	⊙	⊙
	4.0kW	CS-E15DTEW	⊙	⊙	⊙
	5.0kW	CS-E18DTEW	⊙	⊙	⊙
Mini-Cassette	4.0kW	CS-E15B4EW	⊙	⊙	⊙
	5.0kW	CS-E18B4EW	⊙	⊙	⊙
Cassette	2.2kW	CS-ME7EB1E	⊙	⊙	⊙
	2.8kW	CS-ME10EB1E	⊙	⊙	⊙
	3.2kW	CS-ME12EB1E	⊙	⊙	⊙
	4.0kW	CS-ME14EB1E	⊙	⊙	⊙
Capacity range of connectable indoor units			From 5.0kW to 9.0kW		
Pipe length	1-room maximum pipe length (m)		25		
	Allowable elevation (m)		15		
	Total allowable pipe length (m)		50		
	Total pipe length for maximum chargeless length (m)		30		
	Additional gas amount over chargeless length (g/m)		20		

Note: "⊙": Available

### Remarks for CU-3E18EBE:

1. At least two indoor units must be connected.
2. The total nominal cooling capacity of indoor units that will be connected to outdoor unit must be within connectable capacity range of indoor unit. (shown in the above table.)

Example: The below indoor units combination is possible to connect CU-3E18EBE.

(Total nominal capacity of indoor units is 5.0 kW and 9.0 kW)

1) Two CS-ME7DKEG only. (Total nominal cooling capacity is 4.4 kW.)

2) Three CS-E12DKEW only. (Total nominal cooling capacity is 9.6 kW.)

### • Serviceability

- Self diagnosis
- Test Run at both Cooling and Heating rated frequency

### • Built-in drain pump (Cassette and Duct type)

- A drain pump is built in.
- The pipe can rise to 200 mm above the drain outlet.

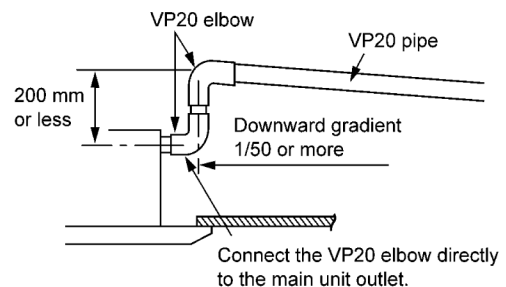

## 2.1. Wall Type

### 2.1.1. Remote Control

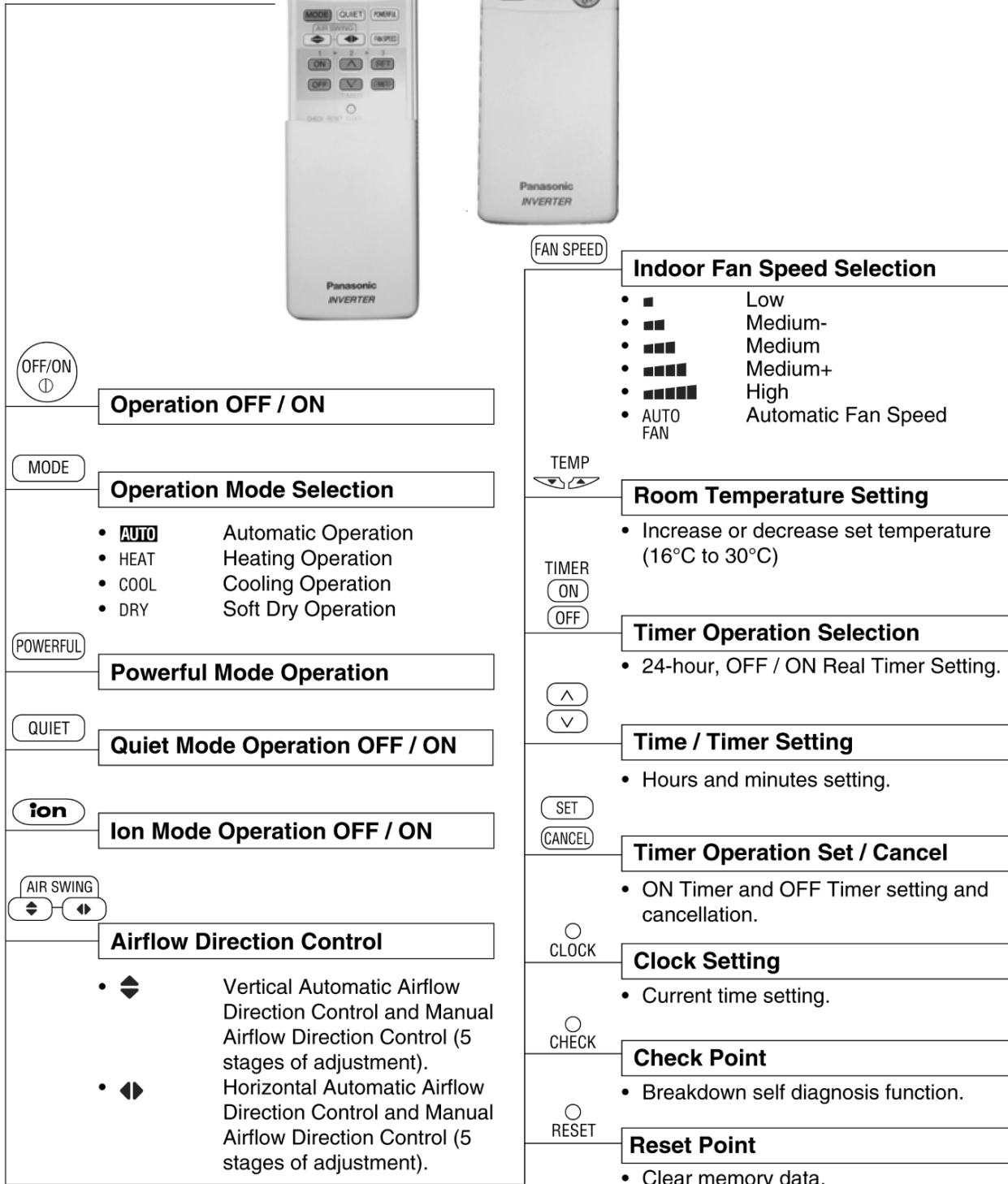

## 2.1.2. Indoor Unit

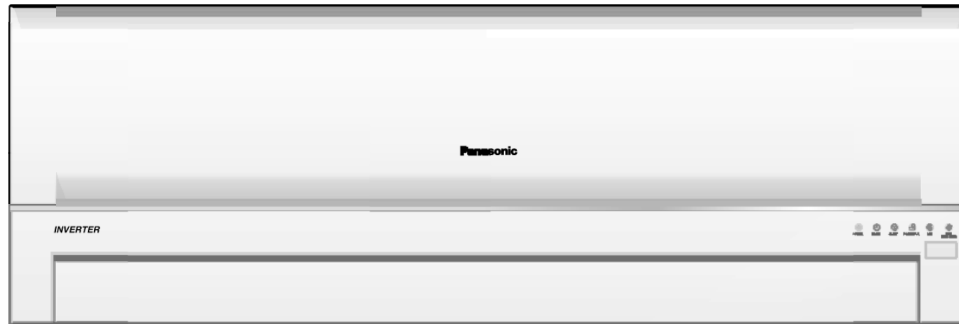

### Simultaneous Operation Control

#### Automatic Operation Switch

- Press for < 5s to run Automatic Operation. (Used when the remote control cannot be used.)
- Press continuously for 5s and < 8s to run Forced Cooling Operation.
- Press continuously for 8s and < 11s to run Forced Heating Operation.
- Press continuously for 11s and < 16s to change different remote controlling setting (A↔B Mode).
- Press continuously for 16s or < 21s to switch OFF / ON Remote Control Receiving Sound or H14 Abnormality Detection Mode.

#### Operation Indication Lamps (LED)

- POWER (Green) ..... Lights up in operation, blinks in Automatic Operation Mode judging and Hot Start operation.
- TIMER (Orange) ..... Lights up in Timer Setting. Blinks in Self Diagnosis Control.
- QUIET (Orange) ..... Lights up in Quiet Mode Operation.
- POWERFUL (Orange) ..... Lights up when Powerful Mode is selected.
- **ion** (Green) ..... Lights up in Ionizer Mode Operation.
- SUPER ALLERU-BUSTER (Blue) ... Lights up in operation.

#### Four Operation Modes

- Automatic, Heating, Cooling and Soft Dry Operation.

#### Automatic and 5 Manual Indoor Fan Speeds

#### Automatic and 5 Manual Vertical Airflow Directions

#### Automatic and 5 Manual Horizontal Airflow Directions

#### Powerful Mode

- For quick cooling or heating.

#### Quiet Mode

- To provide quiet operation.

#### Ion Mode

- Generate negative ion in discharge air.

#### 24 Hours OFF / ON Timer

#### Automatic Restart Control

- Operation is restarted after power failure at previous setting mode.

#### Microcomputer-controlled Room Temperature Control

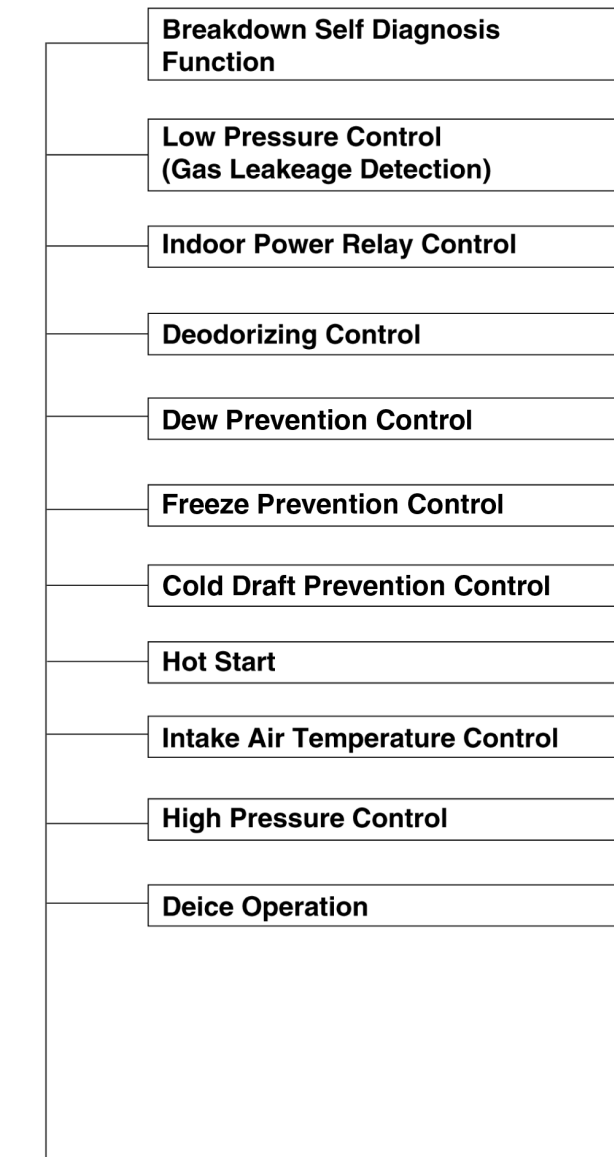

## 2.2. Duct Type

### 2.2.1. Remote Control

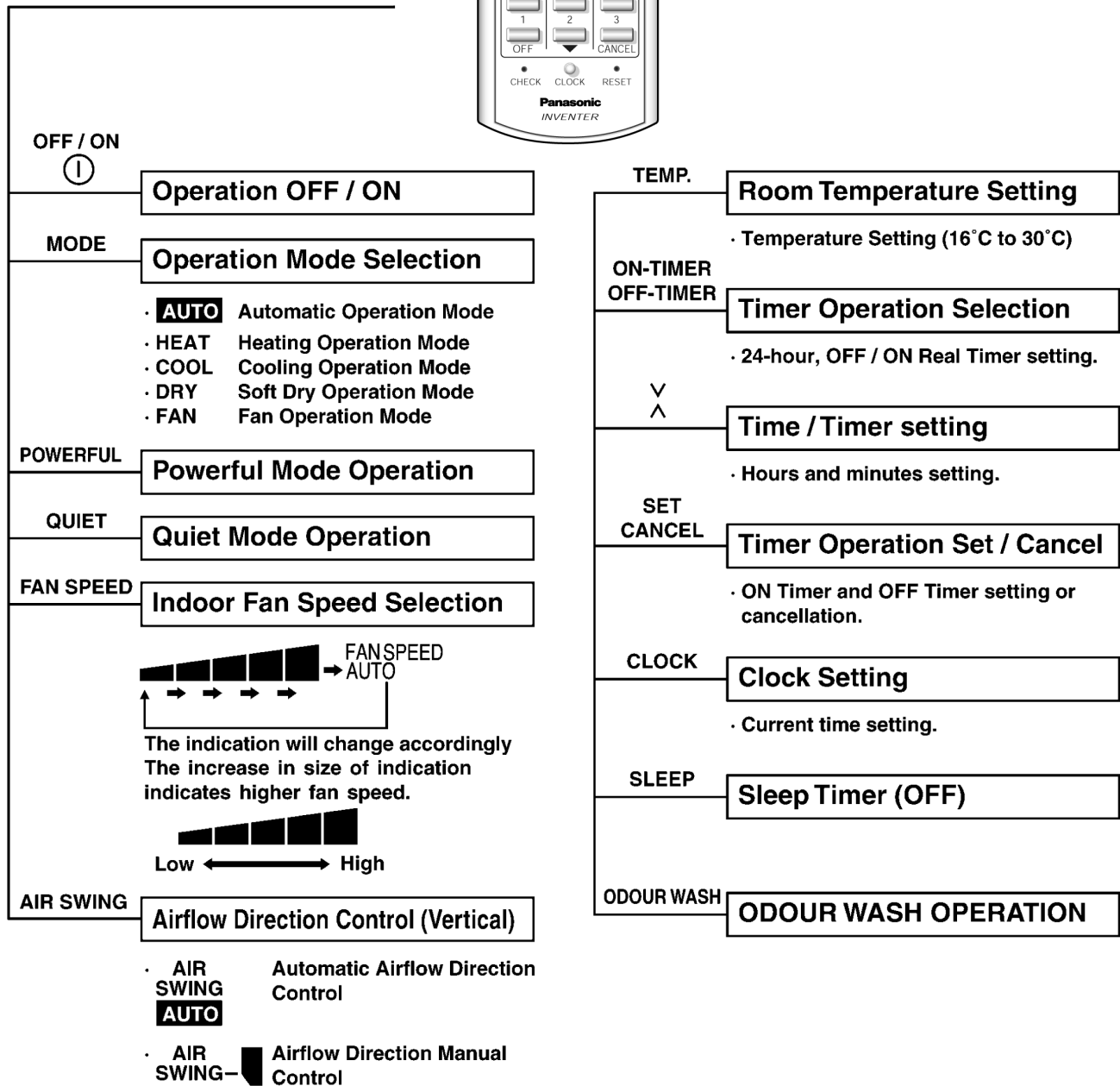
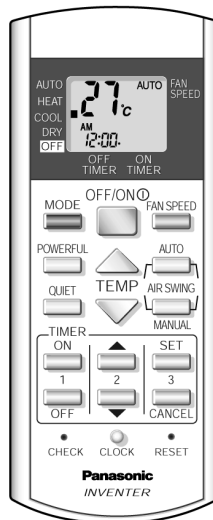

## 2.2.2. Indoor Unit

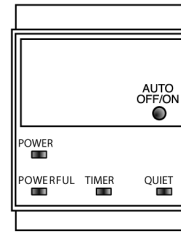
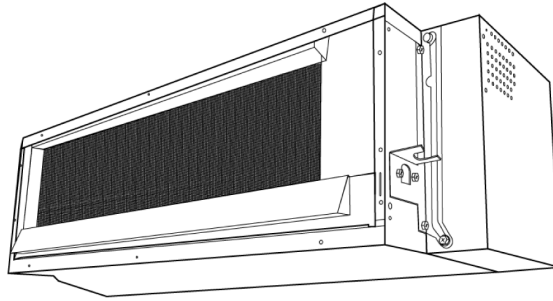

### FOR ALL OPERATIONS

#### Simultaneous Operation Control

#### Operation Indication Lamps

- **POWER (GREEN)** - Lights up in operation, blinks in Automatic Operation judging and Hot Start Control.
- **TIMER (ORANGE)** - Lights up in timer setting. Blinks in Self Diagnosis Control.
- **ODOUR WASH (GREEN)** - Lights up ODOUR WASH Setting.

#### Automatic Operation Switch

- 5s **TEST RUN**
- 5s - 8s **COOLING FORCED OPERATION**
- 8s - 11s **HEATING FORCED OPERATION**
- 11s - 16s **VARIOUS SETTING 1**
  - REMOTE CONTROL A, B, C, D SETTING
- 16s - 21s **ODOUR WASHING**
- 21s - 26s **VARIOUS SETTING 2**
  - BEEP SOUND OFF

#### Operation Mode

- Automatic, Heating, Cooling, Dry and Fan Operation.

#### Automatic Restart Control

- Operation is restarted after power failure at previous setting mode.

#### Sleep timer / Sleep Operation Mode

#### QUIET Mode

#### Timer Operation

#### Odour Operation

#### Powerful Mode

- For quick cooling or heating

#### Indoor Fan Speed Control

#### Airflow Direction Control

#### Room Temperature Control

#### Temperature Shift

#### Self Diagnosis

**HEATING OPERATION**

Cold Draft Prevention Control

Hot Start

Intake Air Temperature Control

**COOLING / SOFT DRY OPERATION**

Deodorizing Control

Fog Prevention Control

Dew Prevention Control

Anti-Freezing Control

Drain Pump Control

**AUTOMATIC OPERATION**

**FAN OPERATION**

## 2.3. Ceiling Floor Type

### 2.3.1. Remote Control

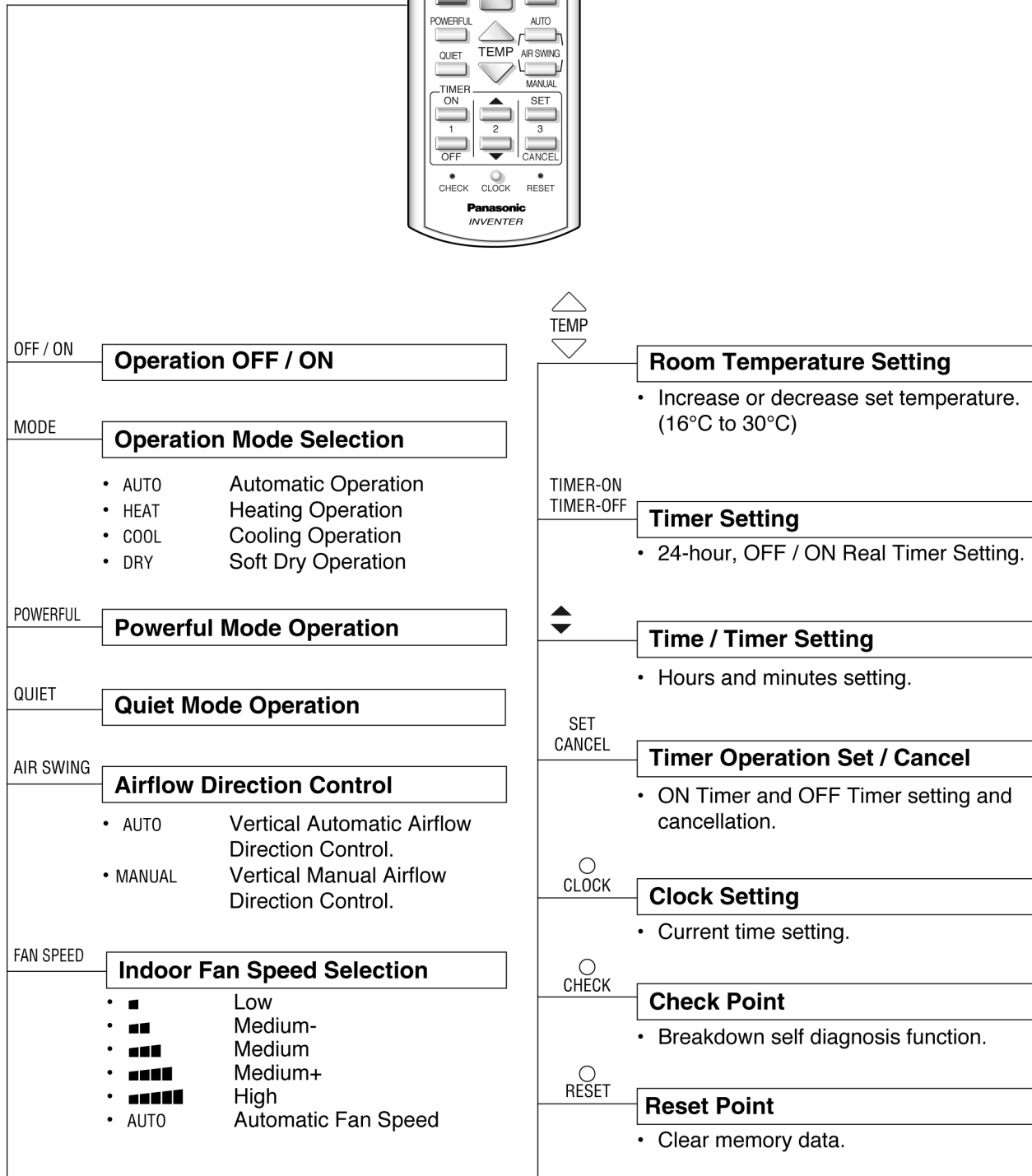
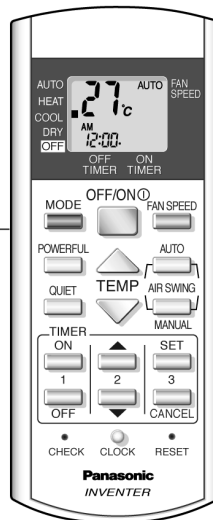

## 2.3.2. Indoor Unit

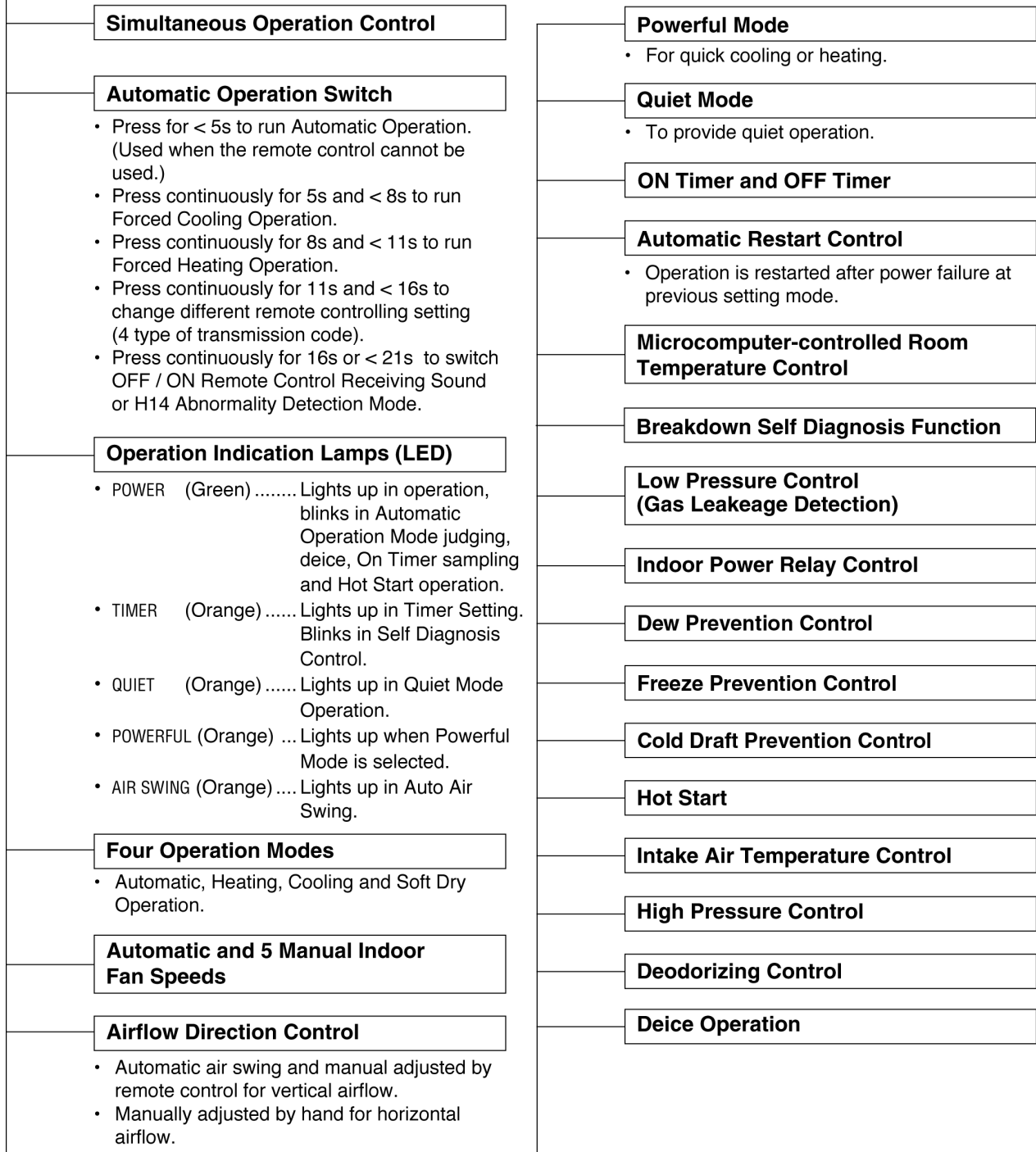
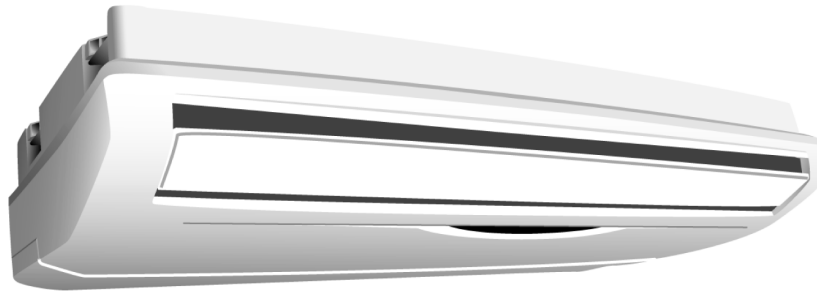

## 2.4. Mini-Cassette Type

### 2.4.1. Remote Control

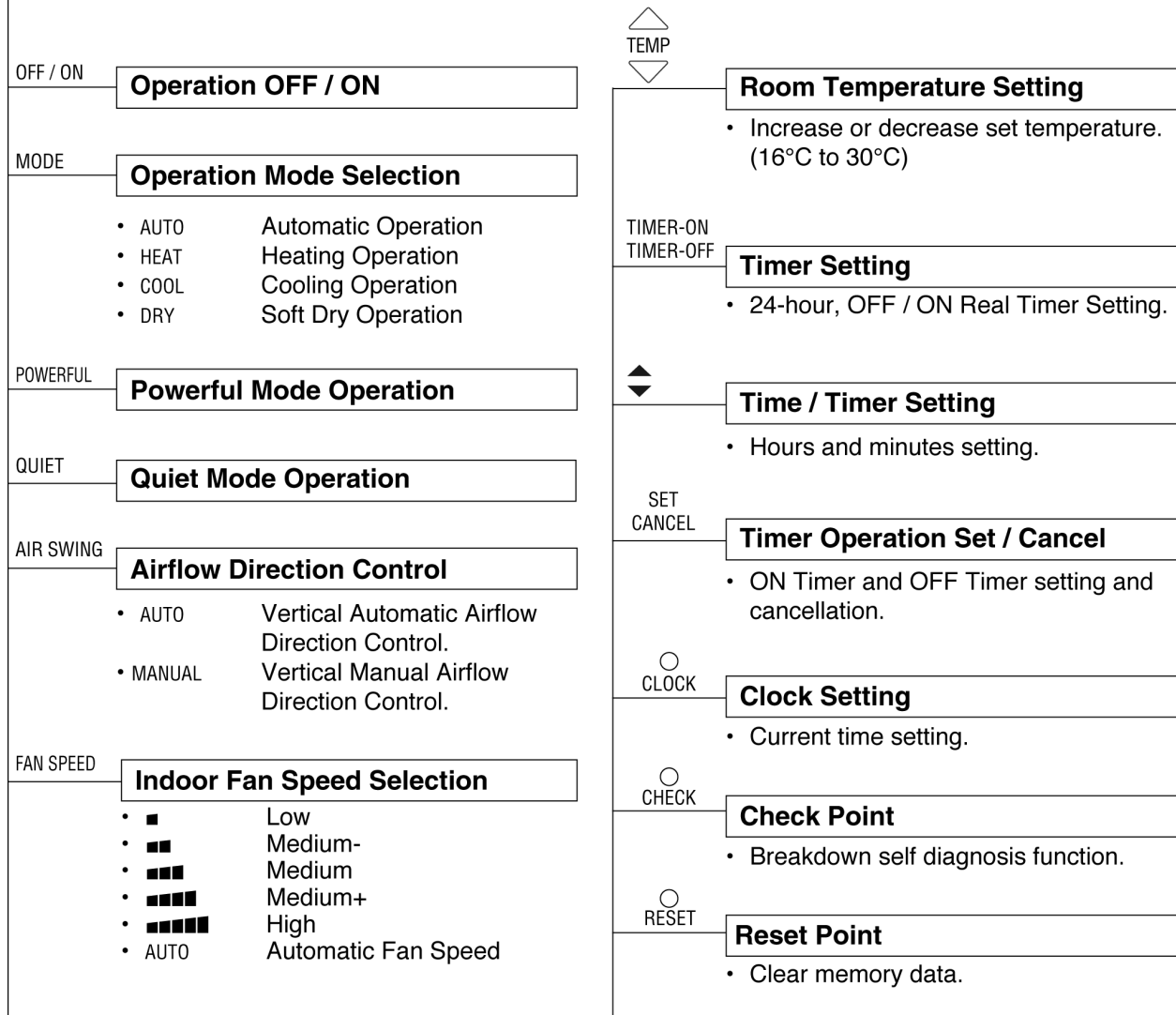
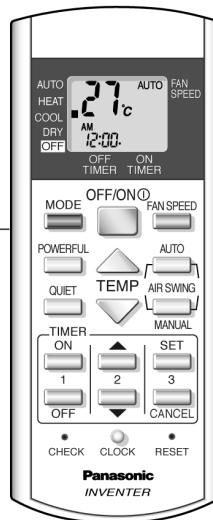

## 2.4.2. Indoor Unit

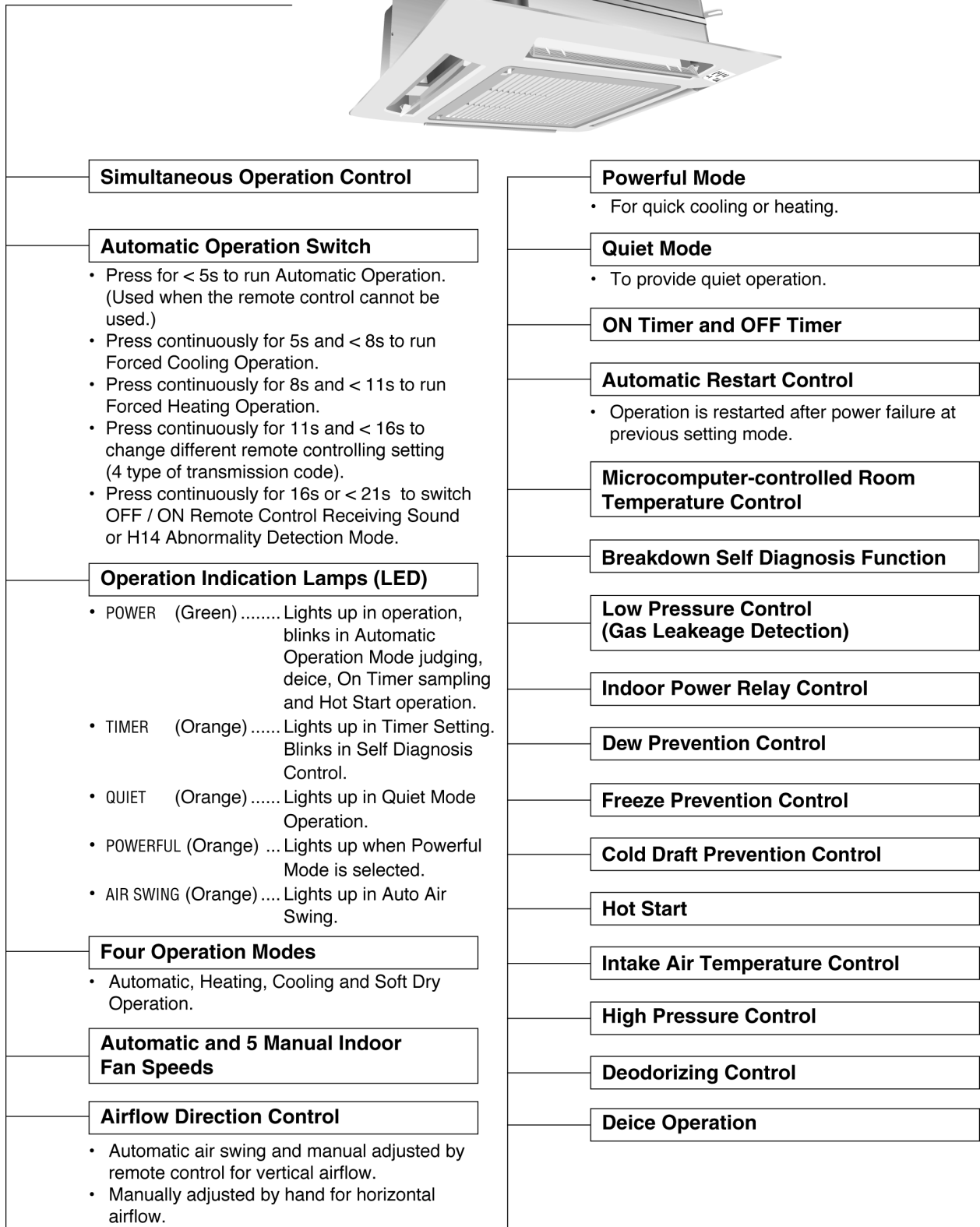

## 3 Product Specifications

### 3.1. Wall Type

Model		Unit	CS-ME7DKEG CS-ME7DKDG	CS-E9DKEW CS-E9DKDW	CS-E12DKEW CS-E12DKDW	CS-E15DKEW CS-E15DKDW	CS-E18DKEW CS-E18DKDW	
Item			Wall Type					
Power Source	Outdoor power		Single 230V 50Hz					
Air Volume	Cooling	m <sup>3</sup> /min (cfm)	High: 9.6 (340)		High: 10.7 (380)	High: 11.0 (390)	High: 13.9 (490)	
	Heating	m <sup>3</sup> /min (cfm)	High: 10.0 (350)		High: 11.2 (400)	High: 11.8 (420)	High: 15.2 (540)	
Noise Level	Cooling (Power)	dB(A) (dB)	High: 40 (53) Low: 29		High: 44 (57) Low: 32	High: 44 (57) Low: 32	High: 46 (59) Low: 33	
	Heating (Power)	dB(A) (dB)	High: 40 (53) Low: 29		High: 44 (57) Low: 32	High: 44 (57) Low: 33	High: 46 (59) Low: 35	
Moisture Removal		L/h (Pint/h)	1.3 (2.8)	1.6 (3.4)	1.8 (3.8)	2.3 (4.8)	2.8 (5.9)	
Refrigeration Piping	Connection	Liquid	mm (inch)	6.35 (1/4")				
		Gas	mm (inch)	9.52 (3/8")		12.7 (1/2")		
Type of Indoor / Outdoor connecting cable		mm	4 x 1.5 mm <sup>2</sup> flexible cord, type designation 245 IEC 57 (H05RN-F)					
Drain Hose	Inner diameter	mm	16					
	Length	m	0.65					
Dimensions	Height	mm (inch)	280 (11 - 1/32)				275 (10 - 13/16)	
	Width	mm (inch)	799 (31 - 15/32)				998 (39 - 9/32)	
	Depth	mm (inch)	183 (7 - 7/32)				230 (9 - 1/16)	
Net Weight		lb (kg)	20 (9.0)				24 (11.0)	
Air Circulation	Type		Cross-flow Fan					
	Motor	Type	Transistor (8-poles)					
		Output	W	30				
Heat Exchanger			Plate fin configuration, forced draft					
		Row / Stage		2/15				
Thermostat			Electronic Control					
Protection Device			Electronic Control					
Air Filter			P.P. Honeycomb					

- Specifications are subject to change without notice for further improvement.

### 3.2. Duct Type

Model		Unit	CS-ME10DD3EG	CS-E15DD3EW	CS-E18DD3EW
Item			Duct Type		
Power Source	Outdoor power		Single 230V 50Hz		
Air Volume	Cooling	m <sup>3</sup> /min (cfm)	High: 7.0 (250)	High: 7.8 (280)	High: 10.3 (360)
	Heating	m <sup>3</sup> /min (cfm)	High: 8.9 (310)		High: 12.6 (440)
Noise Level	Cooling (Power)	dB(A) (dB)	High: 31 (47) Low: 27	High: 33 (49) Low: 27	High: 41 (57) Low: 30
	Heating (Power)	dB(A) (dB)	High: 35 (51) Low: 27	High: 35 (51) Low: 28	High: 41 (57) Low: 32
Moisture Removal		L/h (Pint/h)	1.6 (3.4)	2.3 (4.9)	2.8 (5.9)
Refrigeration Piping	Connection	Liquid	6.35 (1/4")		
		Gas	9.52 (3/8")	12.7 (1/2")	
Type of Indoor / Outdoor connecting cable		mm	4 x 1.5 mm <sup>2</sup> flexible cord, type designation 245 IEC 57 (H05RN-F)		
Drain Hose	Inner diameter	mm	VP20		
	Length	m	0.255		
Dimensions	Height	mm (inch)	235 (9 - 1/4)		285 (11 - 7/32)
	Width	mm (inch)	750 (29 - 17/32)		
	Depth	mm (inch)	370 (14 - 9/16)		
Net Weight		lb (kg)	17 (37)		18 (40)
Air Circulation	Type		Sirocco Fan		
	Motor	Type	Transistor 8-poles		
		Output	W	30	
Heat Exchanger			Plate fin configuration, forced draft		
	Row / Stage		2/8		3/12
Thermostat			Electronic Control		
Protection Device			Electronic Control		
Air Filter			—		

- Specifications are subject to change without notice for further improvement.

### 3.3. Ceiling Floor Type

Model		Unit	CS-ME10DTEG	CS-E15DTEW	CS-E18DTEW
Item			Ceiling Floor Type		
Power Source	Outdoor power		Single 230V 50Hz		
Air Volume	Cooling	m <sup>3</sup> /min (cfm)	High: 9.3 (330)	High: 11.7 (410)	High: 12.1 (430)
	Heating	m <sup>3</sup> /min (cfm)	High: 9.3 (330)	High: 12.0 (420)	High: 12.5 (440)
Noise Level	Cooling (Power)	dB(A) (dB)	High: 39 (52) Low: 31	High: 45 (58) Low: 37	High: 46 (59) Low: 39
	Heating (Power)	dB(A) (dB)	High: 40 (53) Low: 31	High: 45 (58) Low: 33	High: 47 (60) Low: 35
Moisture Removal		L/h (Pint/h)	1.6 (3.3)	2.3 (4.9)	2.8 (5.9)
Refrigeration Piping	Connection	Liquid	mm (inch)	6.35 (1/4")	
		Gas	mm (inch)	9.52 (3/8")	12.7 (1/2")
Type of Indoor / Outdoor connecting cable		mm	4 x 1.5 mm <sup>2</sup> flexible cord, type designation 245 IEC 57 (H05RN-F)		
Drain Hose	Inner diameter	mm	16		
	Length	m	0.65		
Dimensions	Height	mm (inch)	540 (21 - 9/32)		
	Width	mm (inch)	1028 (40 - 1/2)		
	Depth	mm (inch)	200 (7 - 7/8)		
Net Weight		lb (kg)	17 (37)		18 (40)
Air Circulation	Type		Backward Fan		
	Motor	Type	Transistor 8-poles		
		Rate Output	W	51	
Heat Exchanger			Plate fin configuration, forced draft		
	Row / Stage		2/12		
Thermostat			Electronic Control		
Protection Device			Electronic Control		
Air Filter			P.P. Honeycomb		

- Specifications are subject to change without notice for further improvement.

### 3.4. Mini-Cassette Type

Model		Unit	CS-E15DB4EW	CS-E18DB4EW
Item			Mini-Cassette Type	
Power Source	Outdoor power		Single 230V / 240V, 50Hz	
Air Volume	Cooling	m <sup>3</sup> /min (cfm)	High: 10.5 (370)	High: 11.0 (390)
	Heating	m <sup>3</sup> /min (cfm)	High: 10.8 (380)	High: 11.5 (405)
Noise Level	Cooling (Power)	dB(A) (dB)	High: 34 (47) Low: 26	High: 36 (49) Low: 28
	Heating (Power)	dB(A) (dB)	High: 35 (48) Low: 28	High: 37 (50) Low: 29
Moisture Removal		L/h (Pint/h)	2.3 (4.9)	2.8 (5.9)
Refrigeration Piping	Connection	Liquid	6.35 (1/4")	
		Gas	12.7 (1/2")	
Type of Indoor / Outdoor connecting cable		mm	4 x 1.5 mm <sup>2</sup> flexible cord, type designation 245 IEC 57 (H05RN-F)	
Drain Hose	Inner diameter	mm	30	
	Length	m	0.193	
Dimensions	Height	mm (inch)	260 (10 - 1/4)	
	Width	mm (inch)	575 (22 - 5/8)	
	Depth	mm (inch)	575 (22 - 5/8)	
Net Weight		lb (kg)	18 (40)	
Air Circulation	Type		Backward Fan	
	Motor	Type	Transistor (8-poles)	
		Rate Output	W	40
Heat Exchanger			Plate fin configuration, forced draft	
	Row / Stage		2/10	
Thermostat			Electronic Control	
Protection Device			Electronic Control	
Air Filter			P.P. Honeycomb	

- Specifications are subject to change without notice for further improvement.

### 3.5. Outdoor unit: CU-3E18EBE

Outdoor Unit	Indoor unit combination		Operation mode	Capacity (kW)		Power input (kW)		Current (A)	
	Operation	Class (kW)		Rating	mini - max	Rating	mini - max		
CU-3E18EBE	One-room Operation	2.2	Cooling	2.20	1.8 - 2.9	0.50	0.34 - 0.81	2.5	
			Heating	3.20	1.2 - 4.1	0.74	0.30 - 1.23	3.7	
		2.8	Cooling	2.80	1.8 - 2.9	0.70	0.34 - 0.81	3.3	
			Heating	4.00	1.2 - 4.3	1.05	0.30 - 1.23	5.0	
		3.2	Cooling	3.20	1.8 - 3.8	0.80	0.34 - 1.36	3.7	
			Heating	4.50	1.2 - 5.8	1.23	0.30 - 2.10	5.8	
		4.0	Cooling	4.00	1.8 - 4.3	1.24	0.34 - 1.99	5.6	
			Heating	5.60	1.2 - 6.8	1.72	0.30 - 2.93	7.7	
		5.0	Cooling	5.00	1.9 - 5.7	1.55	0.34 - 2.13	6.8	
			Heating	6.80	1.2 - 6.9	2.10	0.30 - 2.52	9.2	
		Two-room Operation	2.2 + 2.2	Cooling	4.40	1.9 - 6.2	1.11	0.35 - 2.10	4.9
				Heating	5.80	1.4 - 7.0	1.45	0.31 - 2.55	6.4
			2.2 + 2.8	Cooling	5.00	1.9 - 6.2	1.41	0.35 - 2.10	6.2
				Heating	6.40	1.4 - 7.0	1.72	0.31 - 2.55	7.6
	2.2 + 3.2		Cooling	5.20	1.9 - 6.3	1.49	0.35 - 2.11	6.6	
			Heating	6.80	1.4 - 7.3	1.84	0.31 - 2.52	8.2	
	2.2 + 4.0		Cooling	5.20	1.9 - 6.4	1.45	0.35 - 2.11	6.4	
			Heating	6.80	1.4 - 7.3	1.80	0.31 - 2.51	7.9	
	2.2 + 5.0		Cooling	5.20	1.9 - 6.8	1.29	0.36 - 2.15	5.7	
			Heating	6.80	1.4 - 8.0	1.52	0.31 - 2.20	6.7	
	2.8 + 2.8		Cooling	5.20	1.9 - 6.2	1.54	0.35 - 2.10	6.8	
			Heating	6.80	1.4 - 7.0	1.93	0.31 - 2.55	8.5	
	2.8 + 3.2		Cooling	5.20	1.9 - 6.3	1.48	0.35 - 2.11	6.5	
			Heating	6.80	1.4 - 7.3	1.84	0.31 - 2.52	8.1	
	2.8 + 4.0		Cooling	5.20	1.9 - 6.4	1.44	0.35 - 2.11	6.4	
			Heating	6.80	1.4 - 7.3	1.80	0.31 - 2.51	8.0	
	2.8 + 5.0		Cooling	5.20	1.9 - 6.8	1.29	0.36 - 2.15	5.7	
			Heating	6.80	1.4 - 8.0	1.52	0.31 - 2.20	6.7	
	3.2 + 3.2		Cooling	5.20	1.9 - 6.4	1.45	0.35 - 2.12	6.4	
			Heating	6.80	1.4 - 7.5	1.75	0.31 - 2.49	7.7	
	3.2 + 4.0		Cooling	5.20	1.9 - 6.5	1.41	0.35 - 2.12	6.3	
			Heating	6.80	1.4 - 7.5	1.75	0.31 - 2.47	7.8	
	3.2 + 5.0		Cooling	5.20	1.9 - 6.9	1.25	0.36 - 2.15	5.5	
			Heating	6.80	1.4 - 8.0	1.50	0.31 - 2.18	6.6	
	4.0 + 4.0		Cooling	5.20	1.9 - 6.5	1.41	0.35 - 2.12	6.2	
			Heating	6.80	1.4 - 7.6	1.71	0.31 - 2.47	7.5	
	4.0 + 5.0		Cooling	5.20	1.9 - 6.9	1.25	0.36 - 2.16	5.5	
			Heating	6.80	1.4 - 8.0	1.50	0.31 - 2.17	6.6	
	Three-room Operation		2.2 + 2.2 + 2.2	Cooling	5.20	1.9 - 7.2	1.24	0.36 - 2.17	5.4
				Heating	6.78	1.5 - 8.1	1.53	0.32 - 2.12	6.7
			2.2 + 2.2 + 2.8	Cooling	5.20	1.9 - 7.2	1.24	0.36 - 2.17	5.4
				Heating	6.80	1.5 - 8.1	1.53	0.32 - 2.12	6.7
		2.2 + 2.2 + 3.2	Cooling	5.20	1.9 - 7.2	1.23	0.36 - 2.18	5.4	
			Heating	6.80	1.4 - 8.3	1.49	0.32 - 2.11	6.5	
		2.2 + 2.2 + 4.0	Cooling	5.20	1.8 - 7.3	1.23	0.36 - 2.18	5.4	
			Heating	6.80	1.6 - 8.3	1.46	0.32 - 2.11	6.4	
		2.2 + 2.8 + 2.8	Cooling	5.20	1.9 - 7.2	1.24	0.36 - 2.17	5.4	
			Heating	6.80	1.5 - 8.1	1.53	0.32 - 2.12	6.7	
		2.2 + 2.8 + 3.2	Cooling	5.20	1.9 - 7.2	1.23	0.36 - 2.18	5.4	
			Heating	6.80	1.4 - 8.3	1.49	0.32 - 2.11	6.5	
		2.2 + 2.8 + 4.0	Cooling	5.20	1.8 - 7.3	1.22	0.36 - 2.18	5.4	
			Heating	6.80	1.6 - 8.3	1.42	0.32 - 2.11	6.5	
2.2 + 3.2 + 3.2		Cooling	5.20	1.8 - 7.3	1.22	0.36 - 2.18	5.4		
		Heating	6.80	1.6 - 8.3	1.43	0.32 - 2.10	6.3		
2.8 + 2.8 + 2.8		Cooling	5.19	1.9 - 7.2	1.24	0.36 - 2.17	5.4		
		Heating	6.80	1.5 - 8.1	1.53	0.32 - 2.12	6.7		
2.8 + 2.8 + 3.2		Cooling	5.20	1.9 - 7.2	1.23	0.36 - 2.18	5.4		
		Heating	6.80	1.4 - 8.3	1.49	0.32 - 2.11	6.5		

# 4 Dimensions

## 4.1. Wall Type

Models: CS-ME7DKEG / CS-ME7DKDG /  
 CS-E9DKEW / CS-E9DKDW /  
 CS-E12DKEW / CS-E12DKDW  
 CS-E15DKEW / CS-E15DKDW

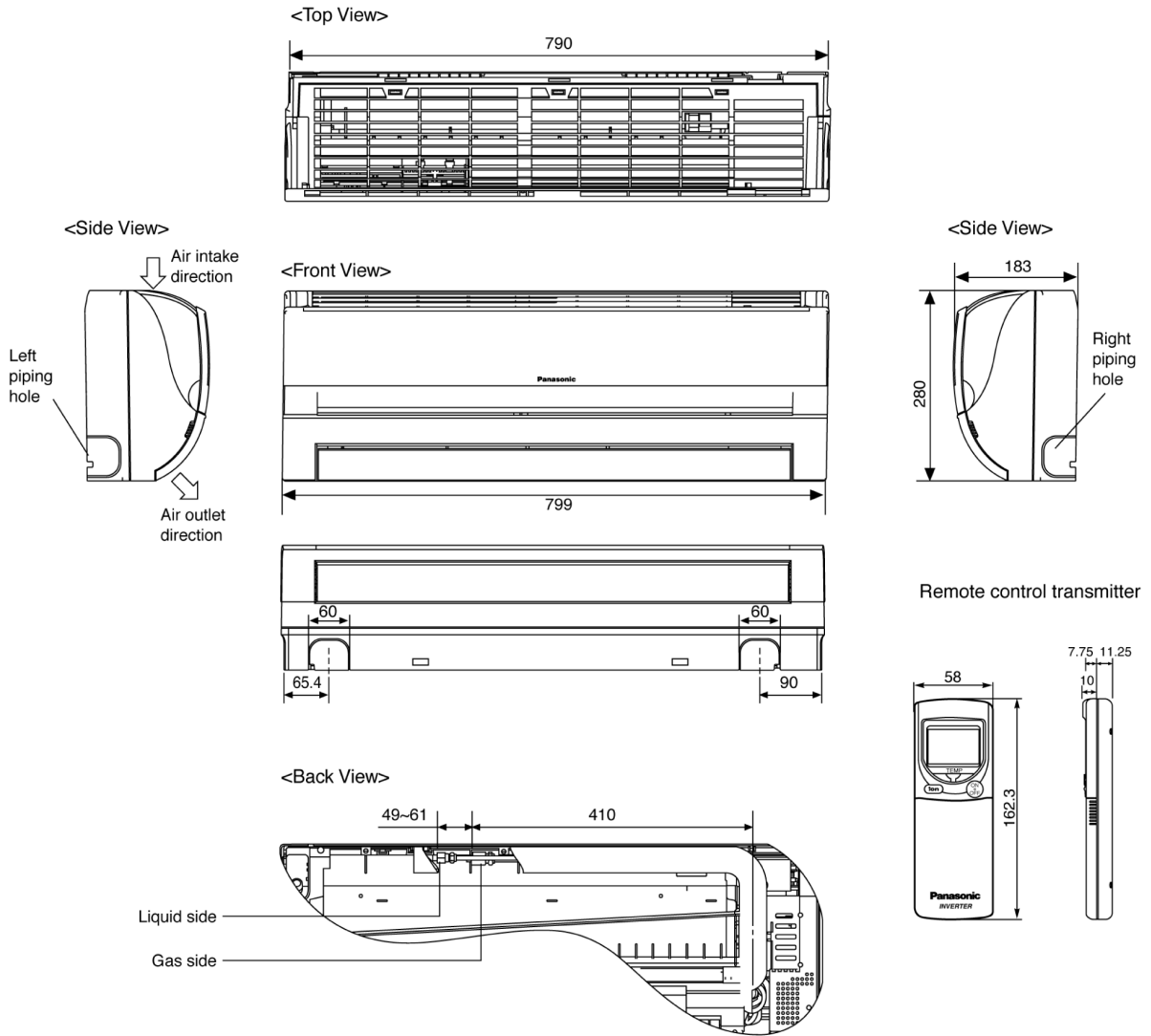

Relative position between the indoor unit and the installation plate <Front View>

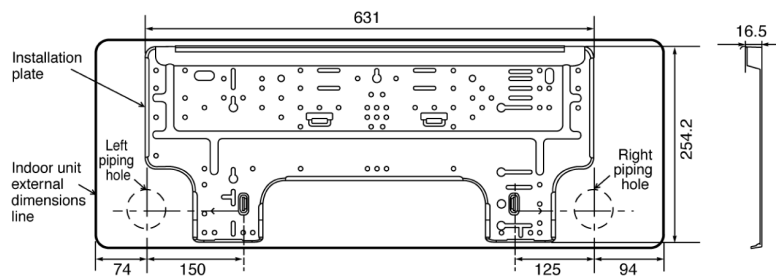

Unit : mm

Models: CS-E18DKEW / CS-E18DKDW

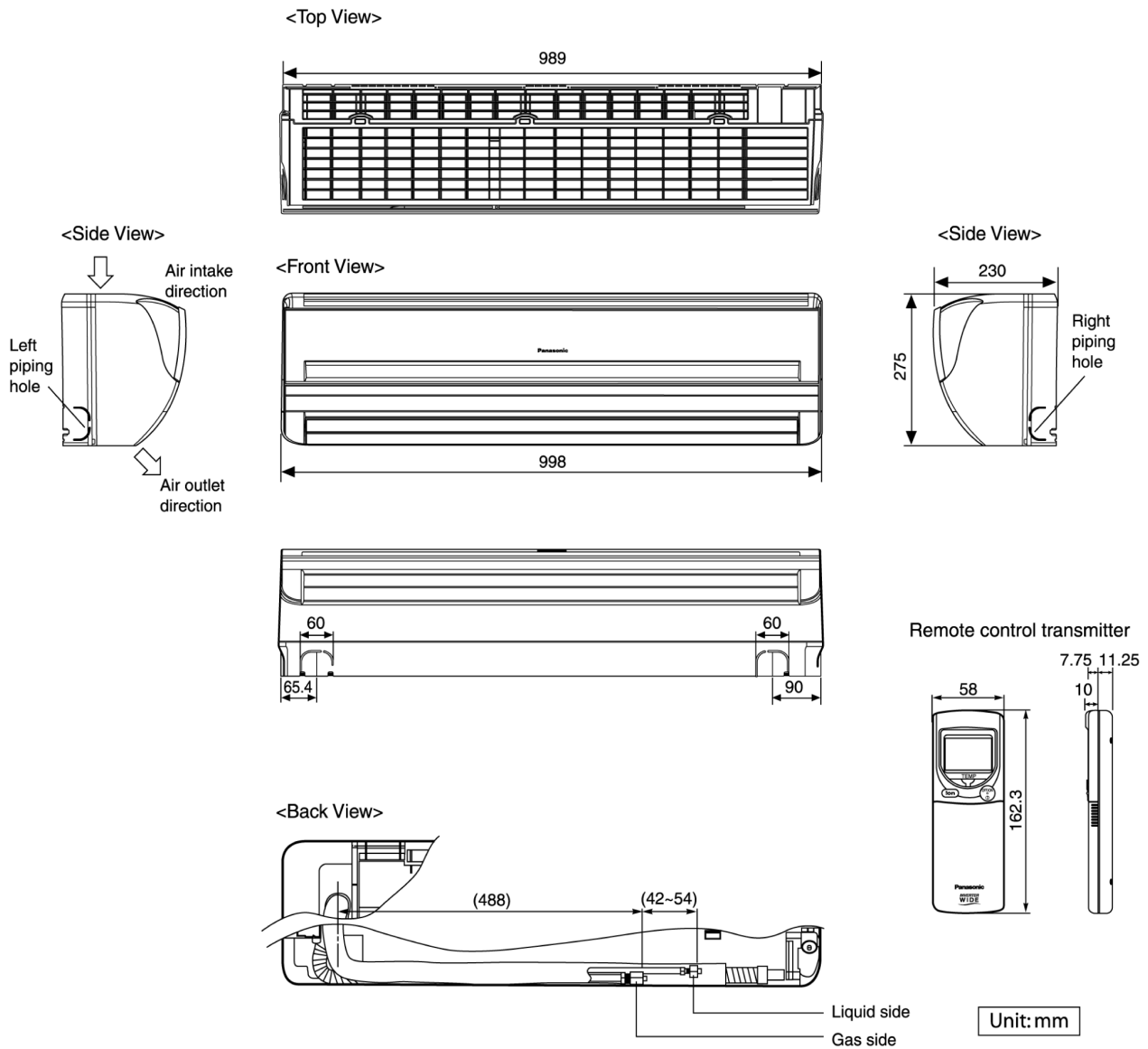

Relative position between the indoor unit and the installation plate <Front View>

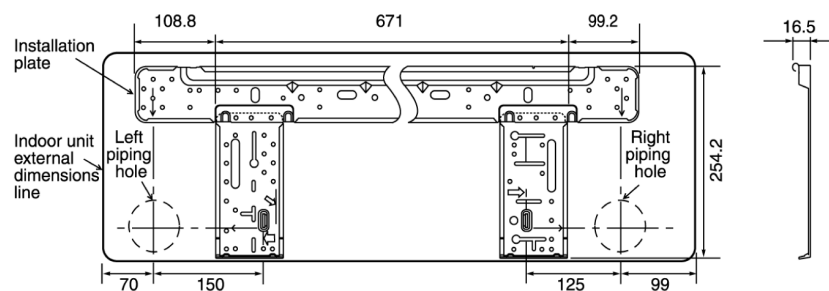

## 4.2. Duct Type

Models: CS-ME10DD3EG / CS-E15DD3EW

<Top View>

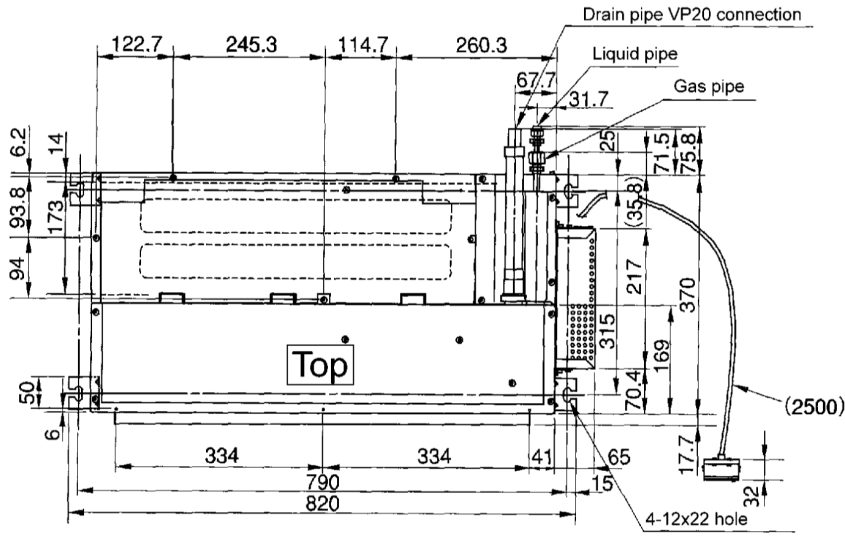

<Remote Control Transmitter>

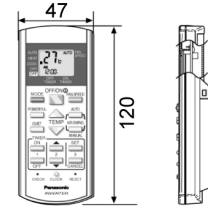

<Remote Control Holder>

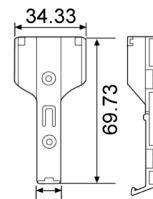

<Front View>

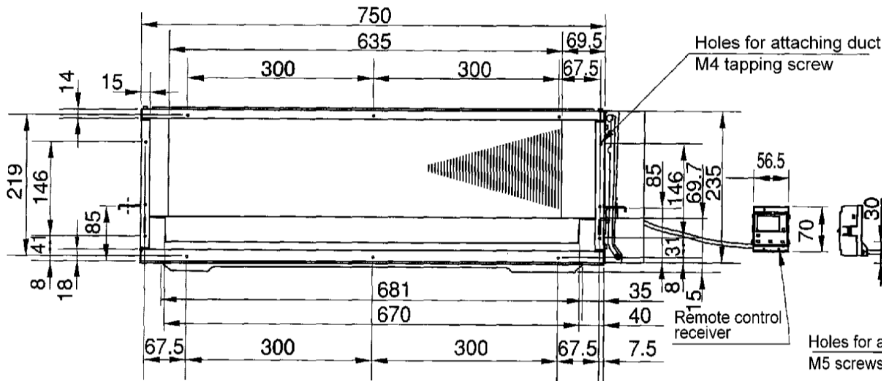

<Side View>

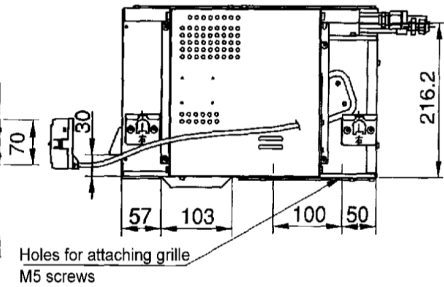

<Back View>

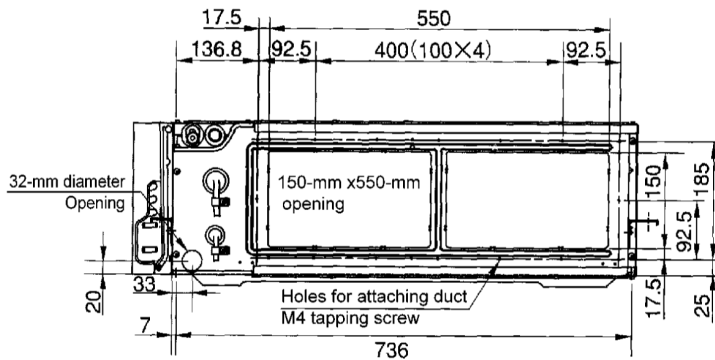

<Detail of the air inlet on the bottom>

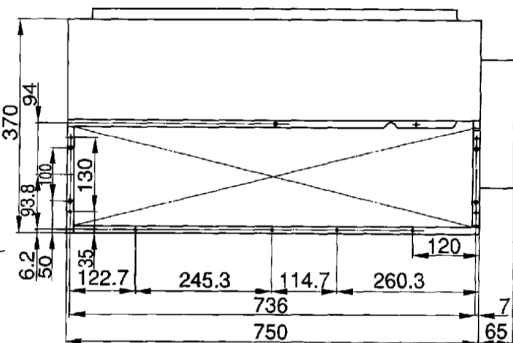

Unit: mm

Model: CS-E18DD3EW

<Back View>

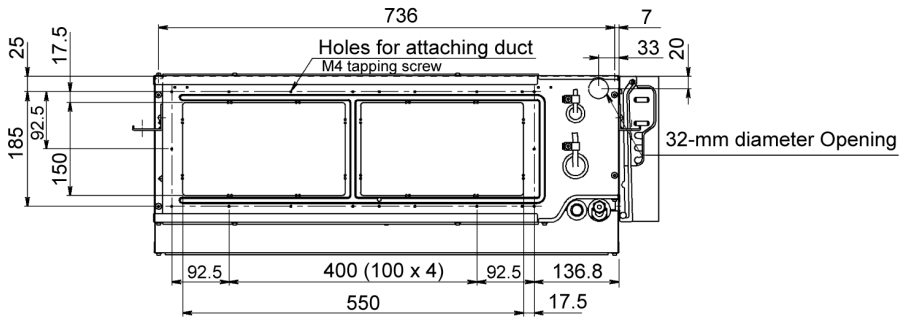

<Remote Control Transmitter>

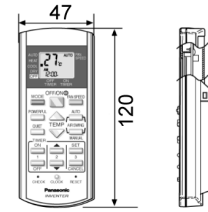

<Remote Control Holder>

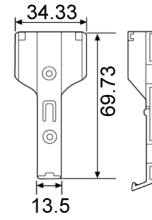

<Top View>

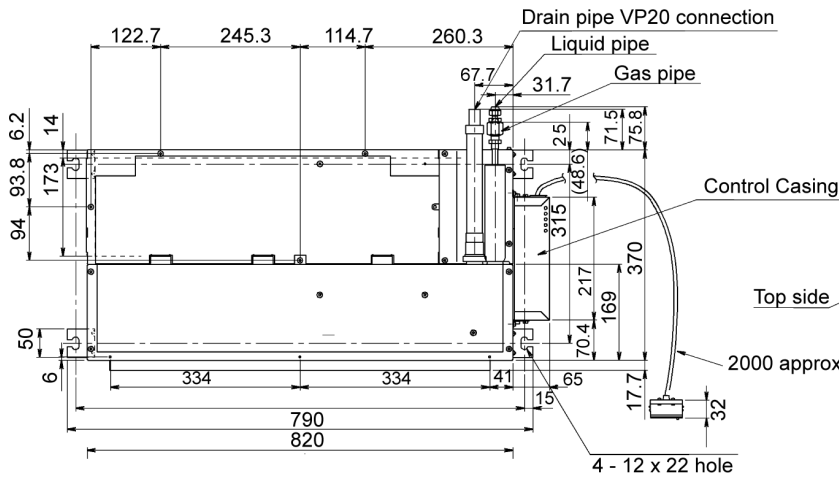

<Side View>

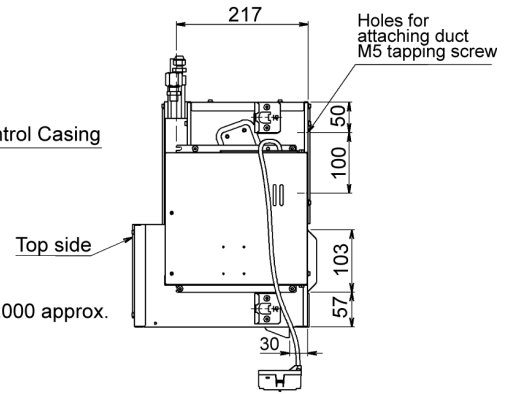

<Front View>

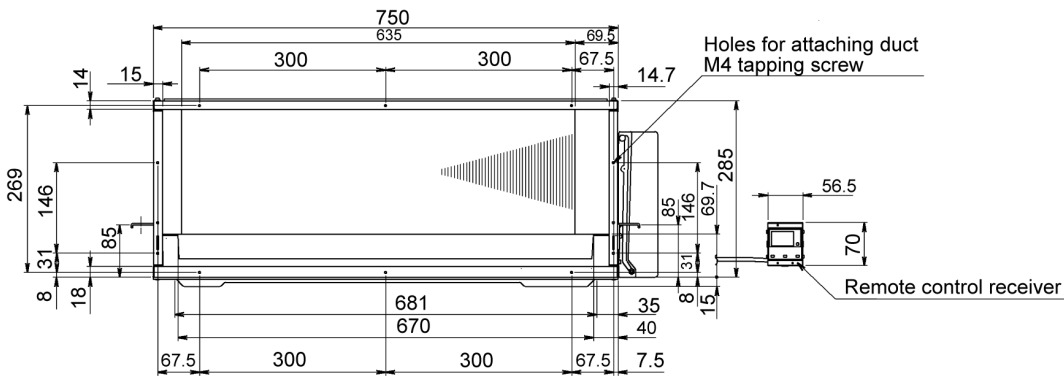

Unit: mm

### 4.3. Ceiling Floor Type

Models: CS-ME10DTEG / CS-E15DTEW / CS-E18DTEW

<Top View>

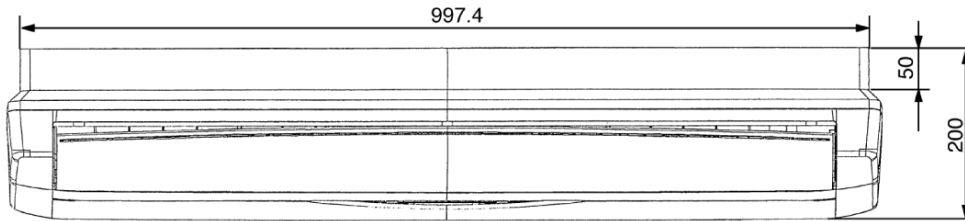

<Front View>

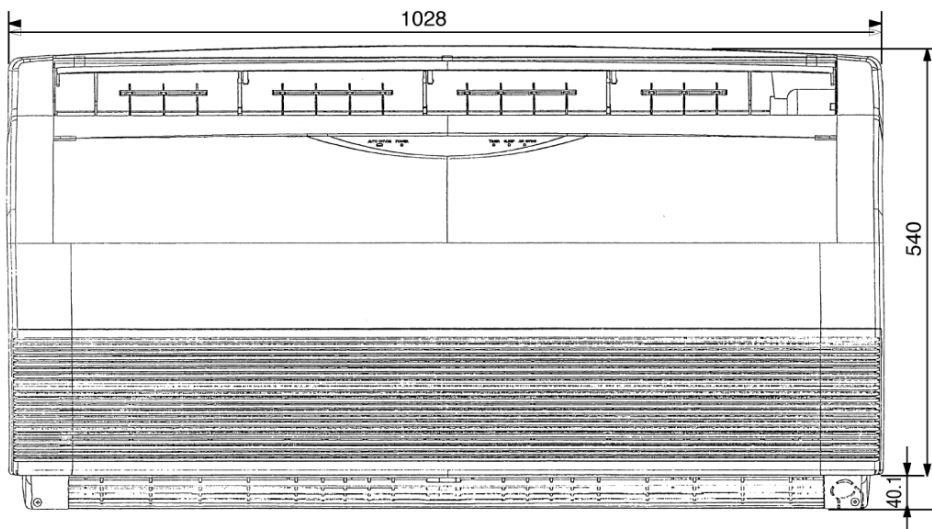

<Side View>

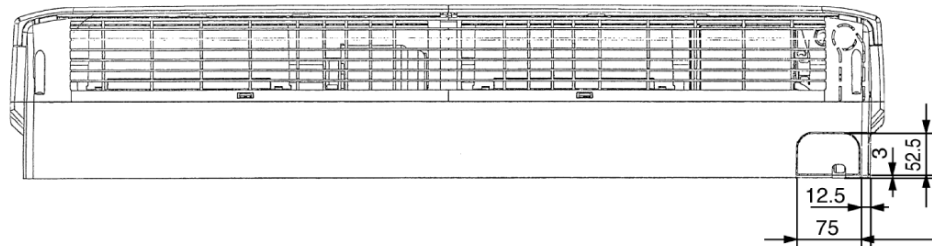
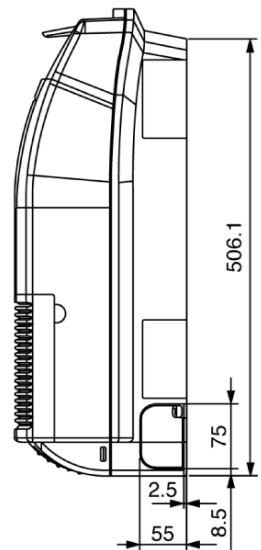

<Remote control transmitter>

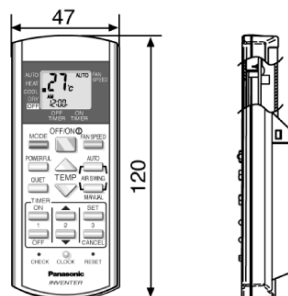

<Remote control holder >

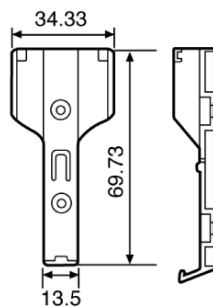

Unit : mm

## 4.4. Mini-Cassette Type

Models: CS-E15DB4EW / CS-E18DB4EW

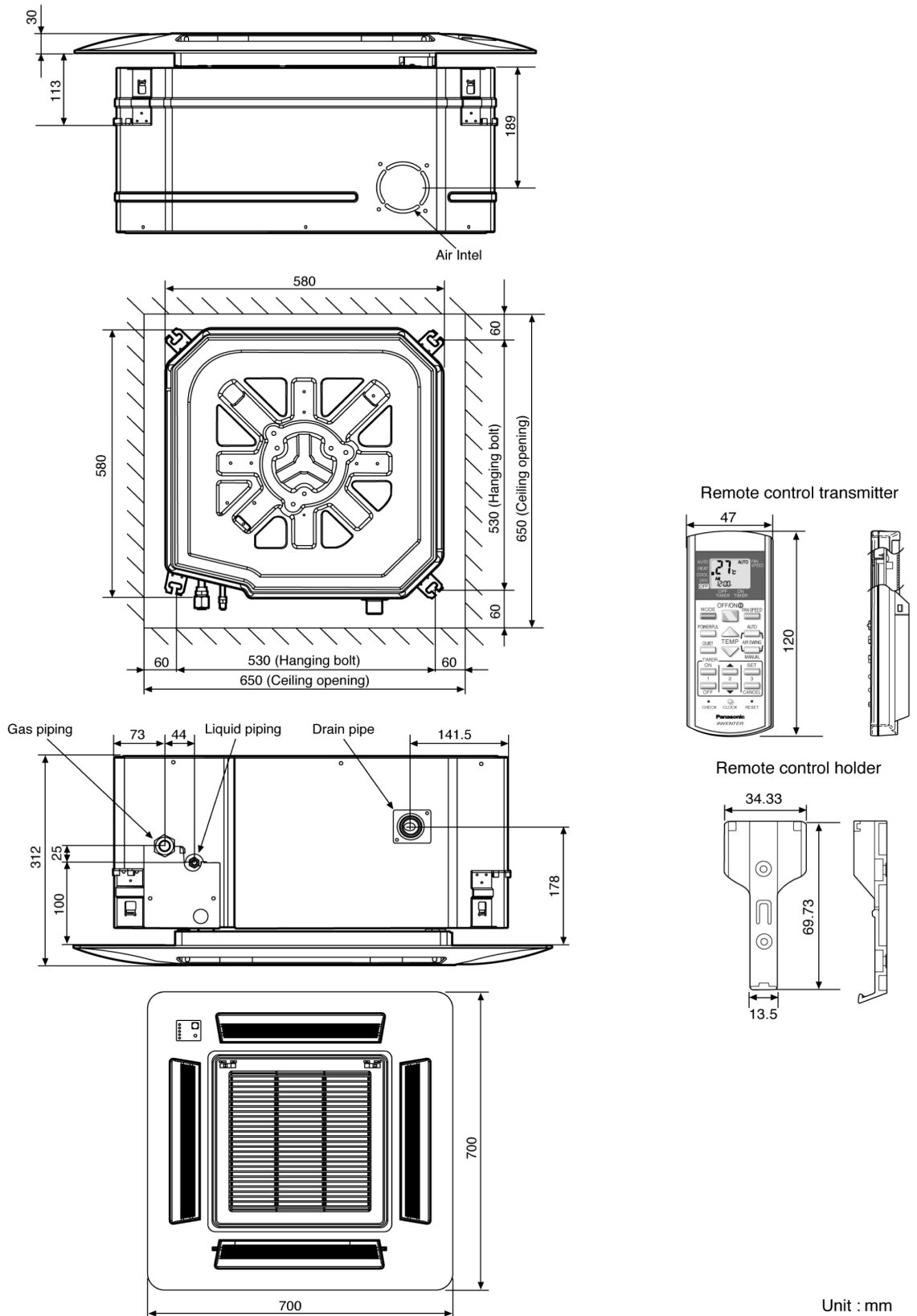

Unit : mm

## 4.5. Outdoor Unit

<Top View>

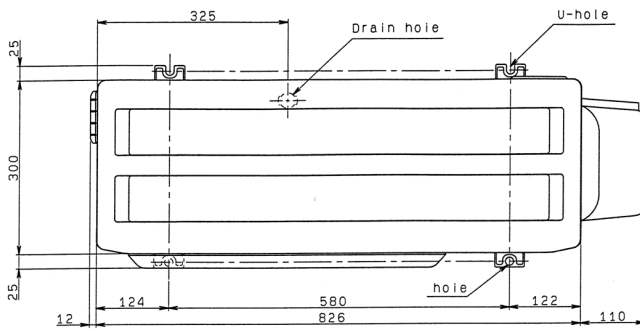

<Front View>

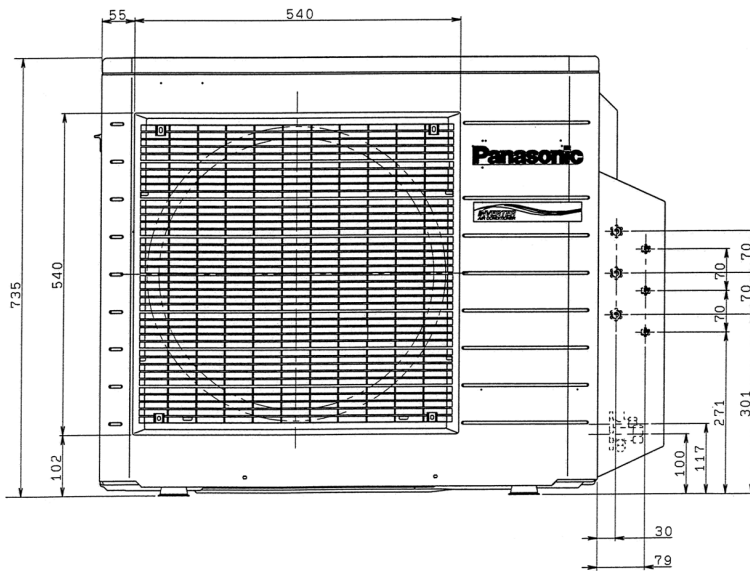

<Side View>

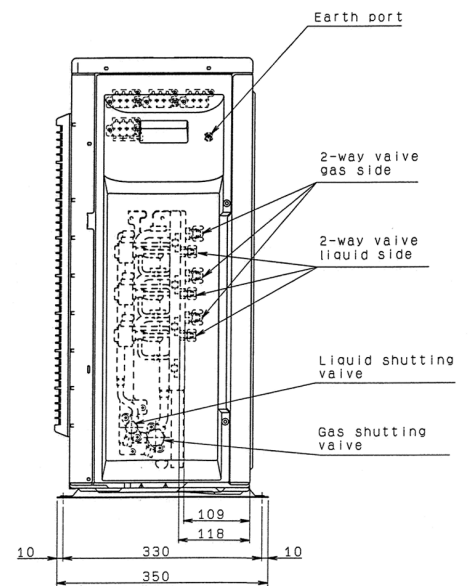

Unit : mm

# 5 Refrigeration Cycle Diagram

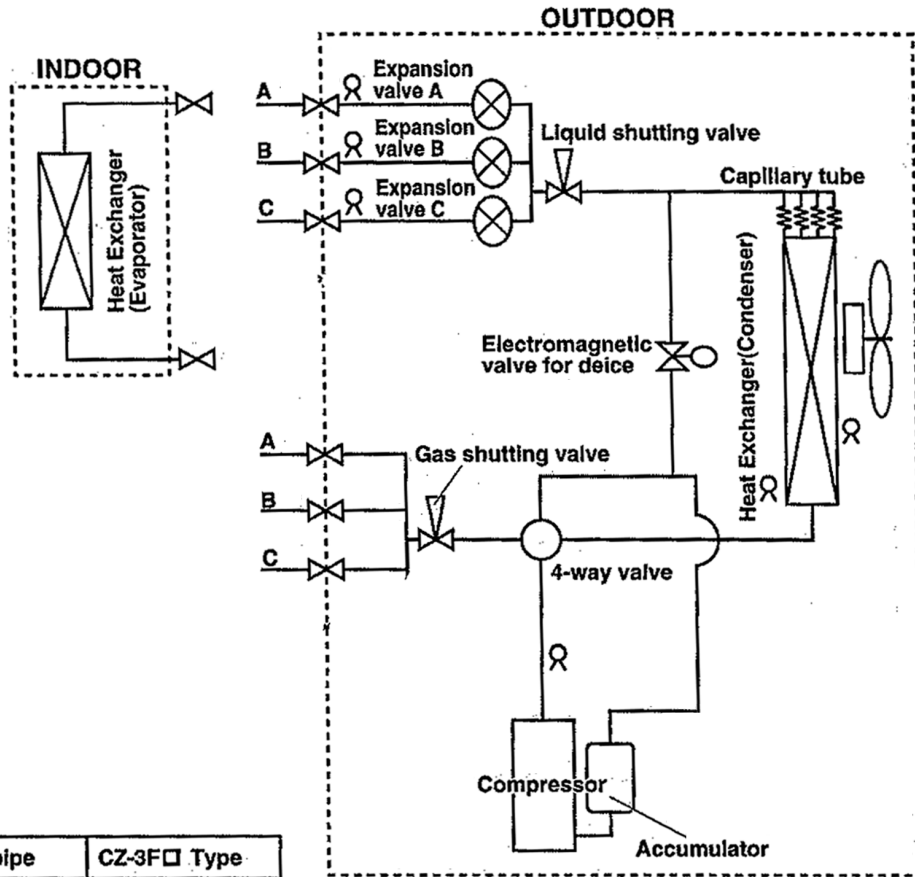

Type of pipe	CZ-3F□ Type
Liquid side pipe	φ6.35mm (1/4")
Gas side pipe	φ9.52mm (3/8")

CONNECTABLE INDOOR UNIT			OUTDOOR UNIT		
ROOM			CU-3E18EBE		
Type			A	B	C
Wall	2.2kW	CS-ME7DKDG	⊙	⊙	⊙
		CS-ME7DKEG	⊙	⊙	⊙
	2.8kW	CS-E9DKDW	⊙	⊙	⊙
		CS-E9DKEW	⊙	⊙	⊙
	3.2kW	CS-E12DKDW	⊙	⊙	⊙
		CS-E12DKEW	⊙	⊙	⊙
	4.0kW	CS-E15DKDW	⊙	⊙	⊙
		CS-E15DKEW	⊙	⊙	⊙
5.0kW	CS-E18DKDW	⊙	⊙	⊙	
	CS-E18DKEW	⊙	⊙	⊙	
Duct	2.8kW	CS-ME10DD3EG	⊙	⊙	⊙
	4.0kW	CS-E15DD3EW	⊙	⊙	⊙
	5.0kW	CS-E18DD3EW	⊙	⊙	⊙

Note:  
"⊙": Available

CONNECTABLE INDOOR UNIT			OUTDOOR UNIT		
ROOM			CU-3E18EBE		
Type			A	B	C
Ceiling Floor	2.8kW	CS-ME10DTEG	⊙	⊙	⊙
	4.0kW	CS-E15DTEW	⊙	⊙	⊙
	5.0kW	CS-E18DTEW	⊙	⊙	⊙
Mini-Cassette	4.0kW	CS-E15B4EW	⊙	⊙	⊙
	5.0kW	CS-E18B4EW	⊙	⊙	⊙
Cassette	2.2kW	CS-ME7EB1E	⊙	⊙	⊙
	2.8kW	CS-ME10EB1E	⊙	⊙	⊙
	3.2kW	CS-ME12EB1E	⊙	⊙	⊙
	4.0kW	CS-ME14EB1E	⊙	⊙	⊙
Capacity range of connectable indoor units			From 5.0kW to 9.0kW		
Pipe length	1-room maximum pipe length (m)		25		
	Allowable elevation (m)		15		
	Total allowable pipe length (m)		50		
	Total pipe length for maximum chargeless length (m)		30		
	Additional gas amount over chargeless length (g/m)		20		

# 6 Wiring Diagram

## 6.1. Wall Type

Models: CS-ME7DKEG / CS-ME7DKDG / CS-E9DKEW / CS-E9DKDW /  
 CS-E12DKEW / CS-E12DKDW / CS-E15DKEW /  
 CS-E15DKDW / CS-E18DKEW / CS-E18DKDW

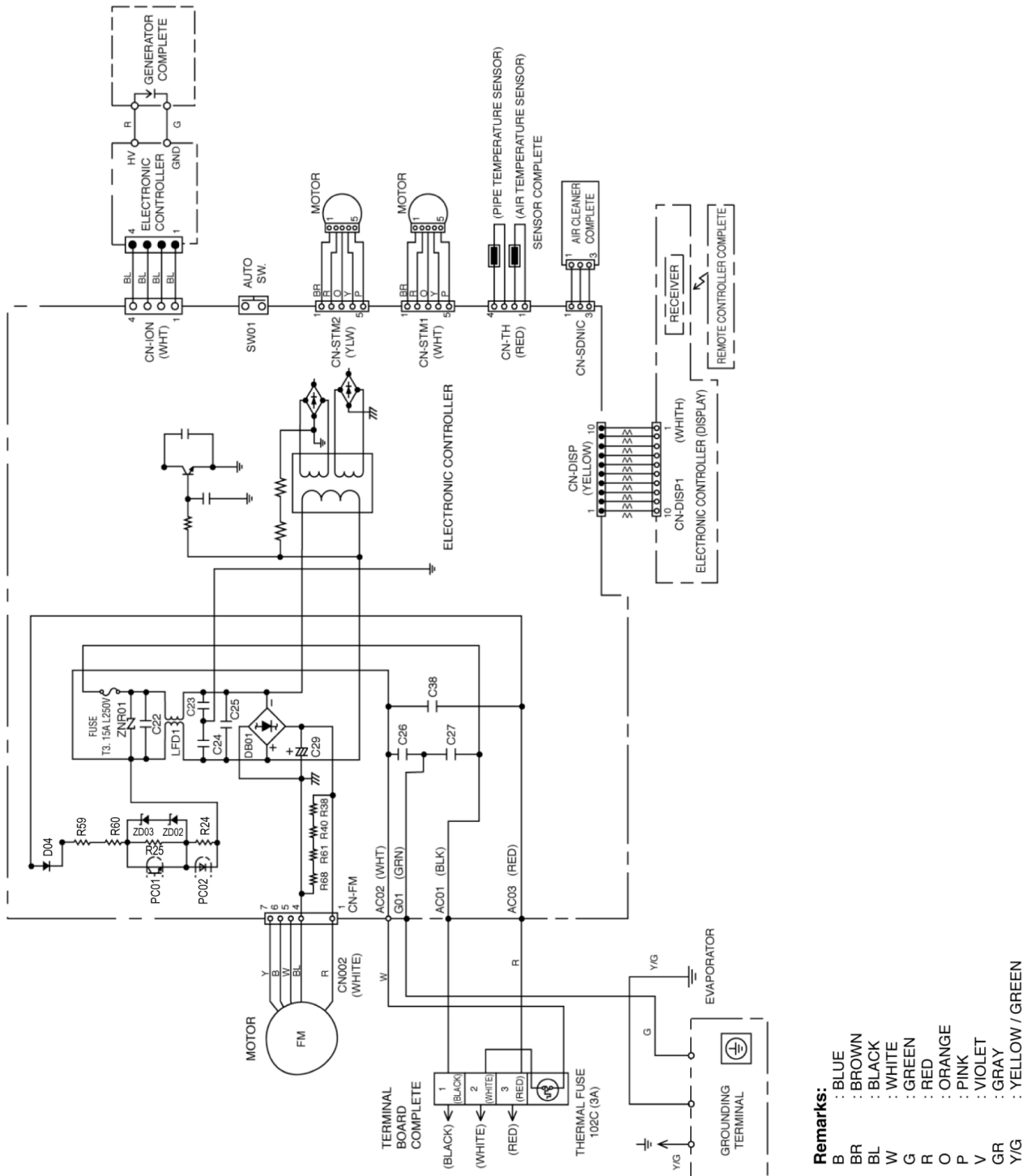

## 6.2. Duct Type

Models: CS-ME10DD3EG / CS-E15DD3EW / CS-E18DD3EW

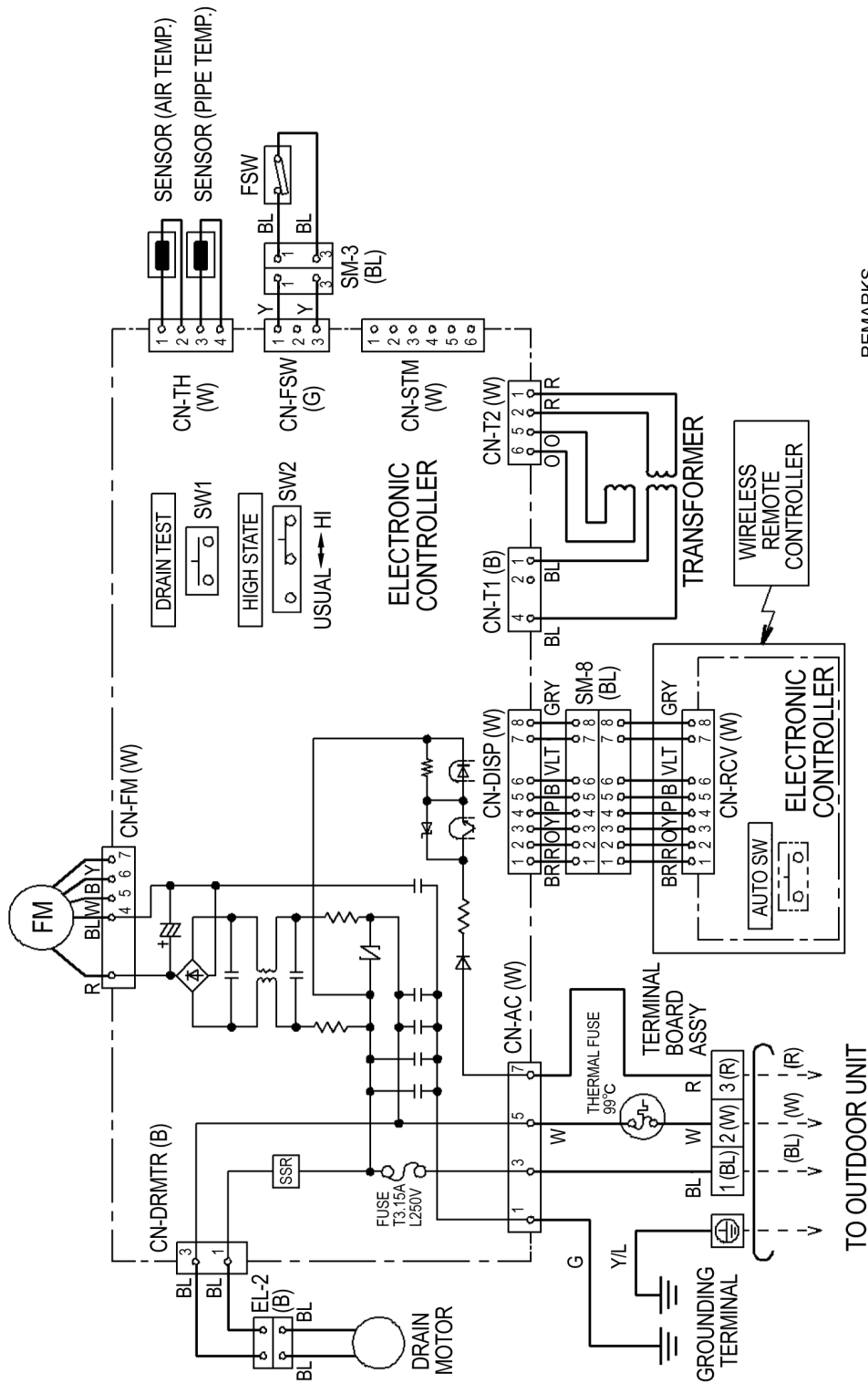

REMARKS  
 B: BLUE BR: BROWN W: WHITE  
 G: GREEN P: PINK Y: YELLOW  
 O: ORANGE GRY: GRAY BL: BLACK  
 R: RED Y/G: YELLOW/GREEN  
 VLT: VIOLET

### 6.3. Ceiling Floor Type

Models: CS-ME10DTEG / CS-E15DTEW / CS-E18DTEW

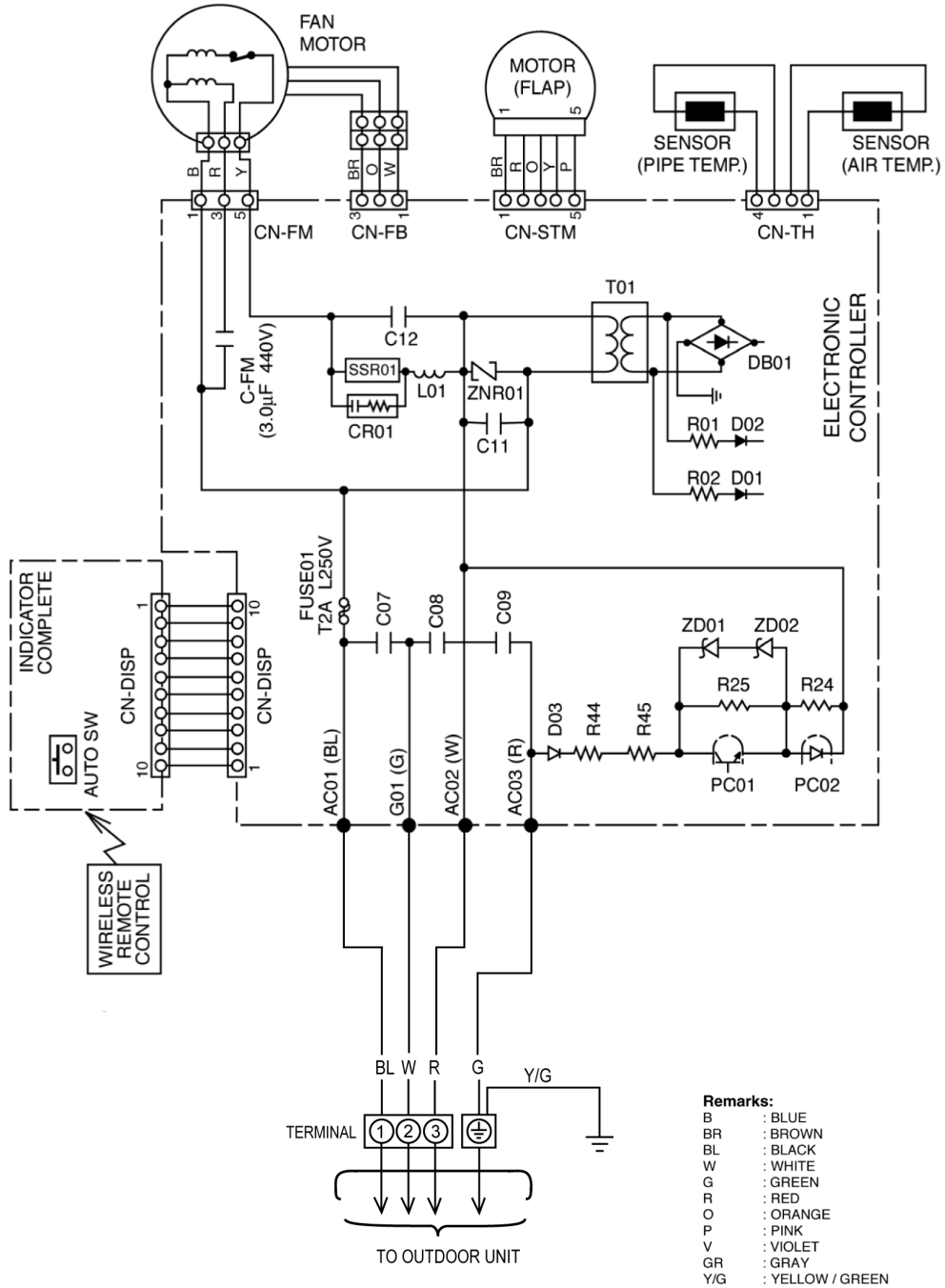

## 6.4. Mini-Cassette Type

Models: CS-E15DB4EW / CS-E18DB4EW

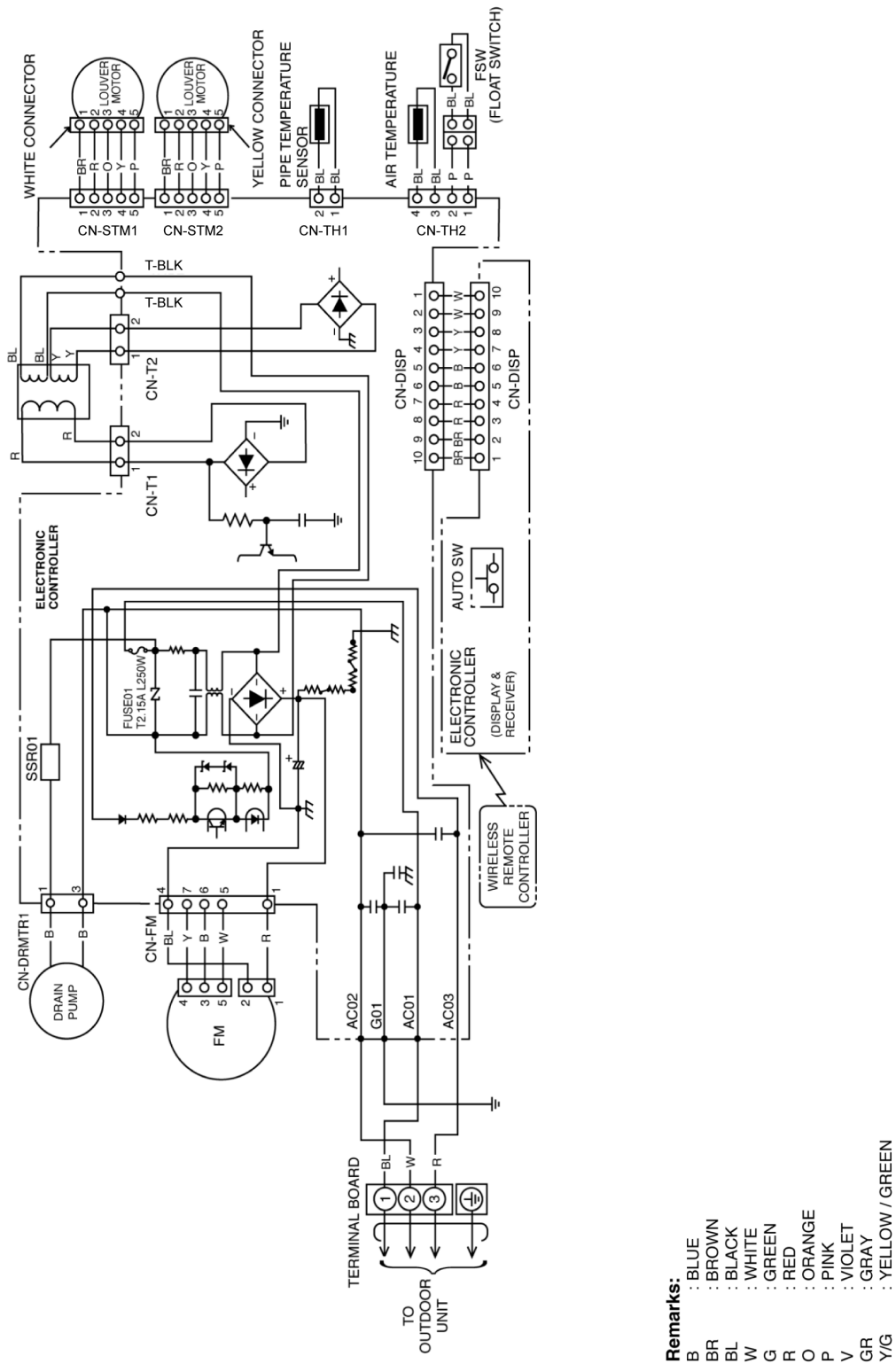

# 6.5. Outdoor Unit

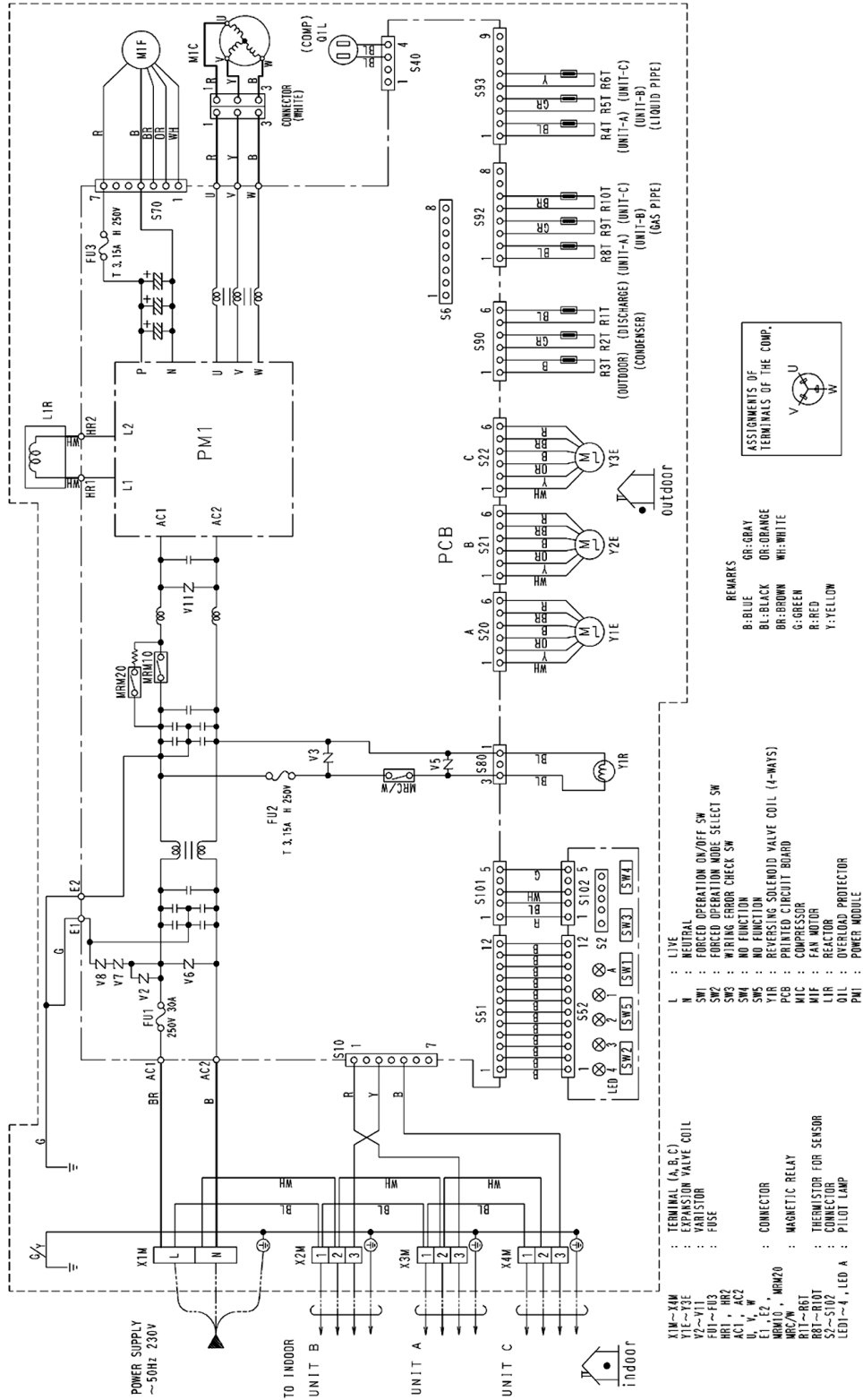

# 7 Electronic Circuit Diagram

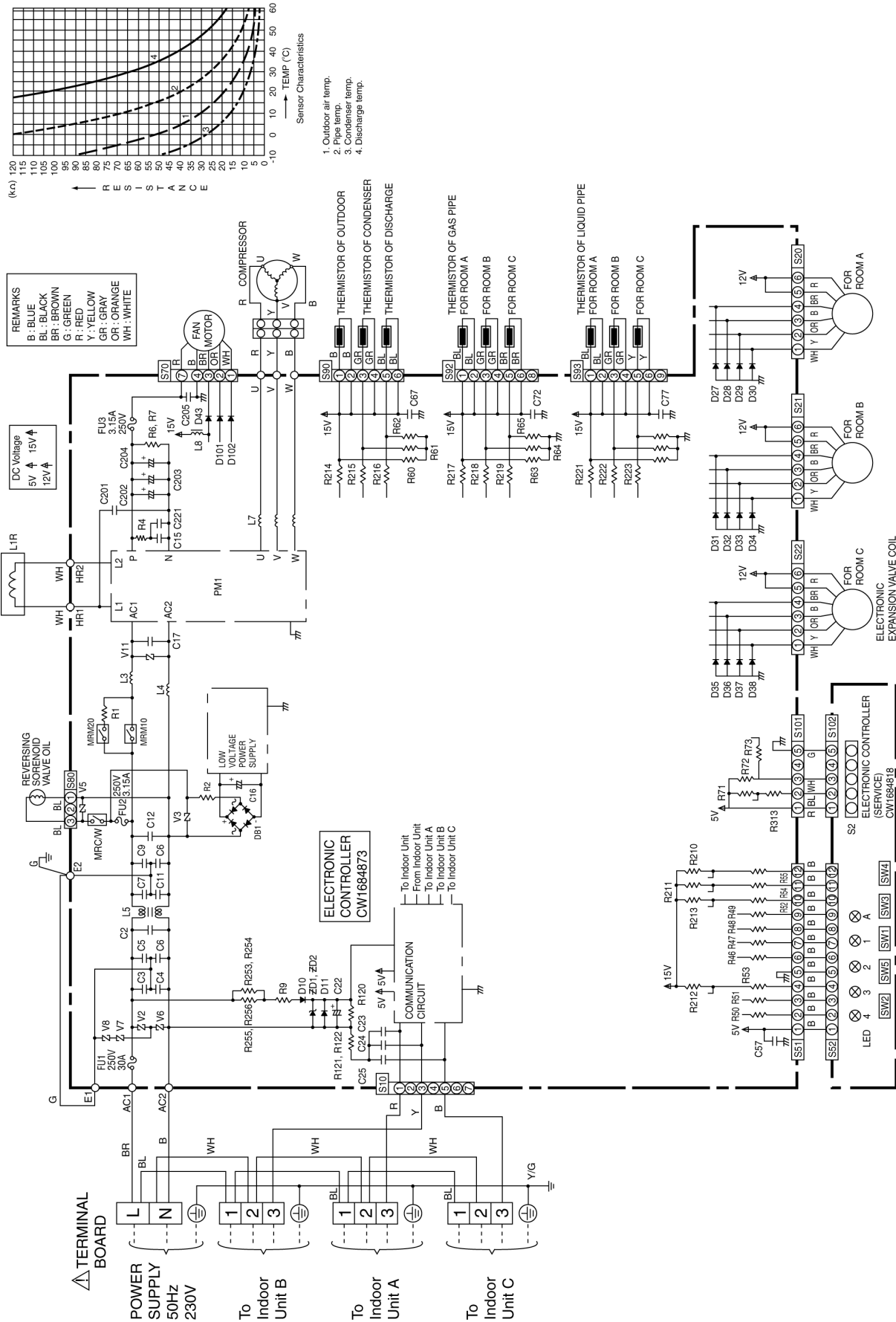

Printed Circuit Board  
CU-3E18EBE

Service monitor

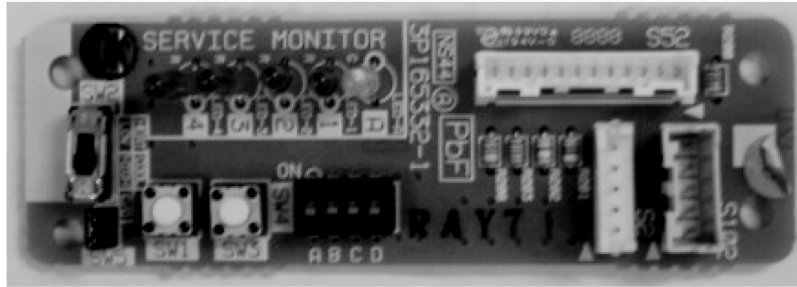

Control board

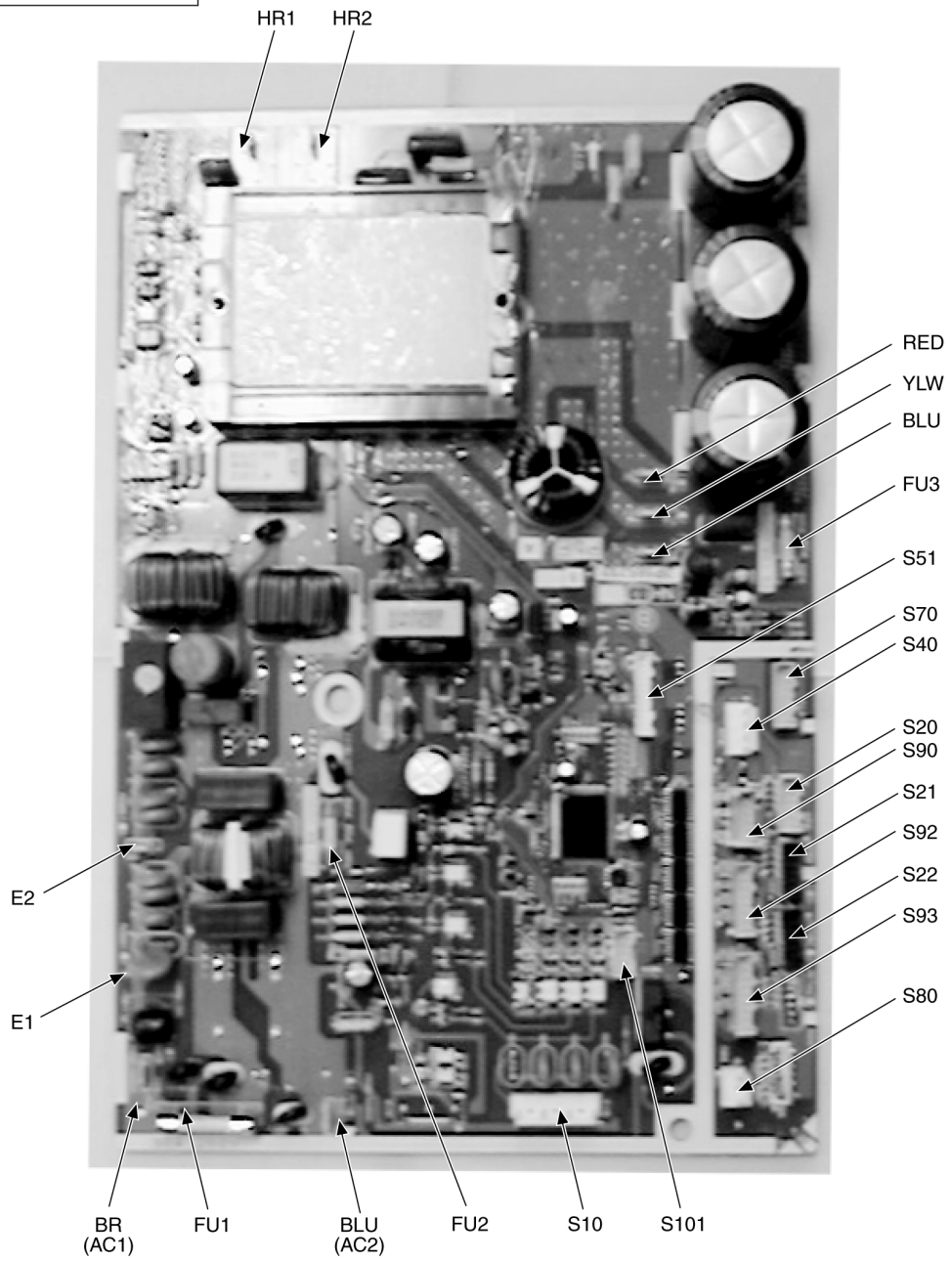

# 8 Operation Details

## 8.1. Wall Type

### 8.1.1. Basic Function

Inverter control, which equipped with a microcomputer in determining the most suitable operating mode as time passes, automatically adjusts output power for maximum comfort always. In order to achieve the suitable operating mode, the microcomputer maintains the set temperature by measuring the temperature of the environment and performing temperature shifting. The compressor at outdoor unit is operating following the frequency instructed by the microcomputer at indoor unit that judging the condition according to internal setting temperature and intake air temperature.

#### 8.1.1.1. Internal Setting Temperature

Once the operation starts, remote control setting temperature will be taken as base value for temperature shifting processes. These shifting processes are depending on the air conditioner settings and the operation environment. The final shifted value will be used as internal setting temperature and it is updated continuously whenever the electrical power is supplied to the unit.

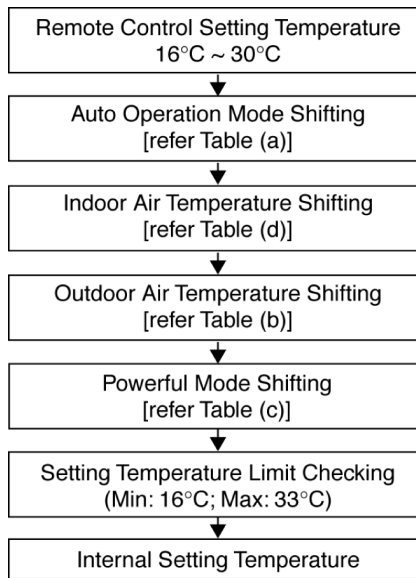

**Table (a): Auto Operation Mode Setting**

Mode Shift:	Temperature Shift (°C)
Cooling/Soft Dry → Heating	-2.0
Heating → Cooling/Soft Dry	+2.0

**Table (b): Outdoor Air Temperature Shifting**

Mode:	Outdoor Temperature, X (°C):	Temperature Shift (°C)
Cooling/Soft Dry	$30 \leq X$	+0.5
	$X < 30$	+1.0
Heating	$9 \leq X$	-1.0
	$5 \leq X < 9$	-0.5
	$1 \leq X < 5$	0.0
	$X \leq 1$	+1.0

**Table (c): Power Mode Shifting**

Mode	Temperature Shift (°C)
Cooling	-4.0
Soft Dry	-2.0
Heating	+6.0

**Table (d): Indoor Air Temperature Shifting**

1. Target room temperature shift value (dGetaDst)

- To offset the absolute gap between detection temperature with actual room temperature.
- The heat exchanger unit's temperature is different based on operation mode, it becomes the action operation mode value.

Actual operation mode	Target room temperature offset value (dGetaDst)
Cooling	(1)
Heating	(2)
Soft Dry	(0)

2. Room temperature shift value (dGeta)

- When compressor ON/OFF, correction of detected room temperature by shift value during defrost etc.
  - i) Initial value when operation starts, or changing the actual operation mode.

Set the offset value at each operation mode. However, in order to improve the heating startup efficiency, the offset value will be changed based on the gap between setting temperature and room temperature.

Actual operation mode	Gap between setting temperature and room temperature	Room temperature offset value (dGeta)
Cool	—	(0)
Heat	(Operation start set temp. - room temp.) < 4°C	(4)
	(Operation start set temp.) ≥ 4°C	(4)
Soft Dry	—	(0)

ii) Updating during operation

During operation, it will compare with the target room temperature offset value at specific period, then the room temperature will be updated.

Actual operation mode	Room temperature zone	Updating period (sec.)
Cool	—	(180)
Heat	A, B, C, D zone	(15)
Soft Dry	—	(180)

Update the room temperature offset value (dGeta)

Temperature condition	Room temp. offset value after modified (dGeta)
Target room temp. offset value > Room temp. offset value (dGetaDst > dGeta)	dGeta + (0.5)
Target room temp. offset value < Room temp. offset value (dGetaDst < dGeta)	dGeta - (0.5)
Target room temp. offset value = Room temp. offset value (dGetaDst = dGeta)	Do not change.

However, if the following condition is occurred, temperature cannot detect correctly and therefore no updating will be done.

- Heating zone E and above (Temperature gap is big and great capacity increased.)
- During deice
- After deice complete \*within 600 sec.
- Comp. stop
- Comp. starting \*within 600 sec.

### 8.1.1.2. Simultaneous Operation Control

1. **Operation modes which can be selected using the remote control unit:**

Automatic, Cooling, Soft Dry, Heating, Fan operation mode.

2. **Types of operations modes which can be performed simultaneously**

- Cooling operation and cooling, Soft Dry or fan operation
- Heating operation and heating operation

3. **Types of operation modes which cannot be performed simultaneously**

- While a cooling operation is in progress, a heating operation cannot be performed by an indoor unit in another room.

In the room where the operation button for cooling was pressed first, the operation is continued. In the room where the operation button for heating was pressed afterward, the operation lamp of the indoor unit blinks, where the attempt is made to establish the heating operation. Its fan is stopped, and the air does not discharged.

- While a heating operation is in progress, a cooling operation cannot be performed by an indoor unit in another room.

In the room where the operation button for heating was pressed first, the operation is continued. In the room where the operation button for cooling was pressed afterward, the operation lamp of the indoor unit blinks, where the attempt is made to establish the cooling operation. Its fan is stopped, and the air does not discharged.

4. **Operation mode priority control**

- The operation mode designated first by the indoor unit has priority.
- If the priority indoor unit stops operation or initiates the fan operation, the priority is transferred to other indoor units.

“Waiting” denotes the standby status in which the operation lamp LED blinks (ON for 2.5 sec. and OFF for 0.5 sec.), and the fan is stopped.

		B ROOM					
		Non Priority Unit (2nd. ON)					
A ROOM			Cooling	Soft Dry	Heating	Fan	
	Priority Unit (1st. ON)	Cooling	C	C	D	Waiting	F
Soft Dry		D	C	D	Waiting	F	
Priority Unit (1st. ON)	Heating	Waiting	Waiting	H	H	Stop	
	Fan *	F	C	F	D	Stop	H

\* In the fan mode, priority is transferred to a non-priority unit.

**Note**

- C: Cooling operation mode
- D: Soft Dry operation mode
- H: Heating operation mode
- F: Fan operation mode

### 8.1.1.3. Cooling Operation

#### 8.1.1.3.1. Thermostat control

- Compressor is OFF when Intake Air Temperature - Internal Setting Temperature  $< -1.5^{\circ}\text{C}$ .
- Compressor is ON after waiting for 3 minutes, if the Intake Air Temperature - Internal Setting Temperature  $>$  Compressor OFF point.

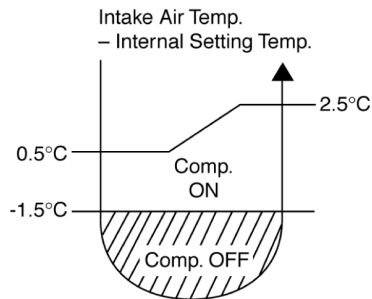

### 8.1.1.4. Soft Dry Operation

#### 8.1.1.4.1. Thermostat control

- Compressor is OFF when Intake Air Temperature - Internal Setting Temperature  $< -2.0^{\circ}\text{C}$ .
- Compressor is ON after waiting for 3 minutes, if the Intake Air Temperature - Internal Setting Temperature  $>$  Compressor OFF point.

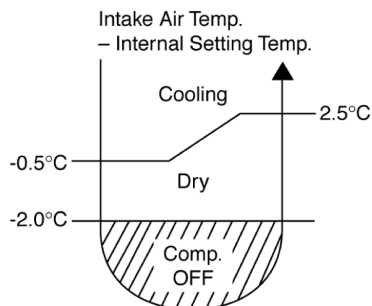

### 8.1.1.5. Heating Operation

#### 8.1.1.5.1. Thermostat control

- Compressor is OFF when Intake Air Temperature - Internal Setting Temperature  $< +2.0^{\circ}\text{C}$ .
- Compressor is ON after waiting for 3 minutes, if the Intake Air Temperature - Internal Setting Temperature  $>$  Compressor OFF point.

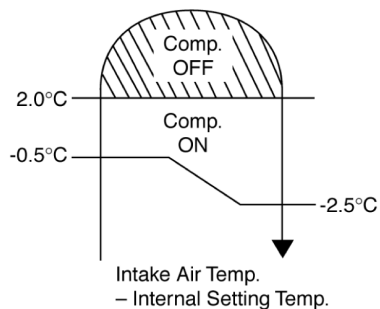

### 8.1.1.6. Automatic Operation

This mode can be set using remote control and the operation is decided by remote control setting temperature, indoor intake air temperature and outdoor air temperature.

During operation mode judgment, indoor fan motor (with speed of Lo-) and outdoor fan motor are running for 30 seconds to detect the indoor intake and outdoor air temperature. The operation mode is decided based on below chart.

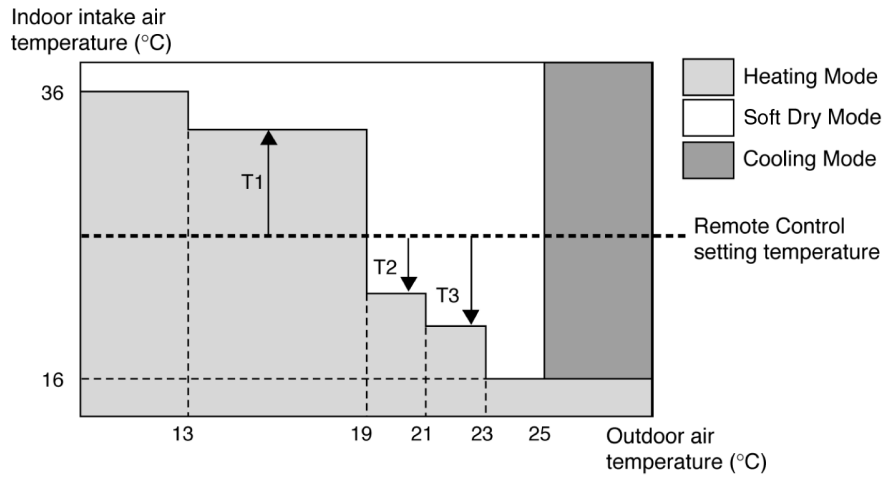

Values of T1, T2, and T3 depend on remote control setting temperature, as shown in below table. After the adjustment of T1, T2 and T3 values, the operation mode for that particular environment and remote control setting is judged and performed, based on the above operation mode chart, every 3 hours.

Remote Control Setting Temperature (°C)	T1	T2	T3
16 ~ 18	+10	-3	-5
19 ~ 22	+8	-3	-7
23 ~ 26	+7	-3	-7
27 ~ 30	+6	-3	-8

There is a temperature shifting on T1, T2, and T3 if the operation mode judged is changed from Cooling/Soft Dry to Heating or vice verse.

Operation Mode change from	Temperature shifts (°C)
Cooling/Soft Dry → Heating	-2
Heating → Cooling/Soft Dry	+2

Example of operation mode chart adjustment:

From the above table, if remote control setting temperature = 25,

$T1 = 25 + 7 = 32$ ;  $T2 = 25 - 3 = 22$ ;  $T3 = 25 - 7 = 18$

The operation mode chart for this example is as shown in below figure and the operation mode to be performed will depend on indoor intake air temperature and outdoor air temperature at the time when the judgment is made.

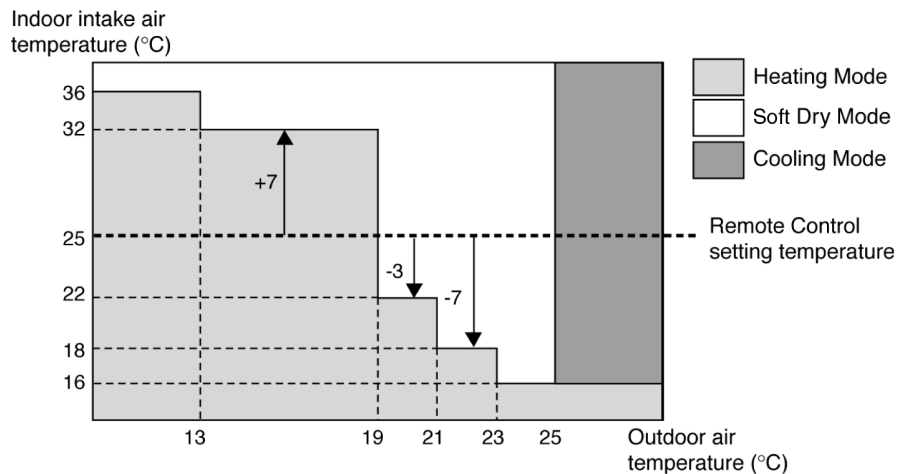

## 8.1.1.7. Indoor Fan Motor Operation

### A. Basic Rotation Speed (rpm)

- Required rotation speed for fan is set to respond to the remote control setting (10 rpm unit)

#### [Cooling, Soft Dry, Fan]

Remote Control	—	—	O	O	O	O	O	—	—	—
Tab (rpm)	PSHi	SHi	Hi	Me+	Me	Me-	Lo	Lo-	SLo	SSLo
CS-ME7DKEG	1320	1320	1280	1210	1040	970	920	860	720	710
CS-E9DKEW	1320	1320	1280	1210	1040	970	920	860	720	710
CS-E12DKEW	1460	1460	1420	1320	1220	1120	1020	950	720	710
CS-E15DKEW	1500	1500	1460	1350	1240	1130	1020	950	720	710
CS-E18DKEW	1540	1540	1450	1340	1240	1140	1040	980	770	640

#### [Heating]

Remote Control	—	—	O	O	O	O	O	—	—	—
Tab (rpm)	PSHi	SSHi	SHi	Me+	Me	Me-	Lo	Lo-	SLo	SSLo
CS-ME7DKEG	1440	1440	1400	1290	1170	1060	950	870	720	710
CS-E9DKEW	1440	1440	1400	1290	1170	1060	950	870	720	710
CS-E12DKEW	1540	1540	1500	1400	1290	1180	1070	990	720	710
CS-E15DKEW	1570	1570	1560	1430	1310	1190	1070	990	720	710
CS-E18DKEW	1640	1640	1580	1470	1350	1230	1110	1040	400	300

#### Notes:

1. Refer to the CS-ME7DKEG column for CS-ME7DKDG.
2. Refer to the CS-E9DKEW column for CS-E9DKDW.
3. Refer to the CS-E12DKEW column for CS-E12DKDW.
4. Refer to the CS-E15DKEW column for CS-E15DKDW.
5. Refer to the CS-E18DKEW column for CS-E18DKDW.

## B. Indoor Fan Control

### i. Indoor fan control operation outline

#### 1. Cooling / Soft Dry

				Cooling	Soft Dry	Ionizer	
Under different mode standby				Stop			
Forced Operation				Hi	—	—	
Other than the above	Min. control	Automatic operation mode judgment		Lo-			
		Freeze proofing		Designated air flow shift	Designated air flow shift	—	
	With dew		Designated air flow shift	Designated air flow shift	—		
	Other than the above	Other than the above	Automatic operation		Lo	SLo	Usually, automatic
			Manual Operation	Powerful	Setting +2(up)		—
				Quiet	Setting -1(down)		—
		Other than the above		Remote control setup	Remote control setup		
		Other than the above	Automatic Operation	Powerful	Powerful automatic	SLo	—
				Quiet	Quiet automatic	SLo	—
			Other than the above	Usually, automatic	SLo	Usually, automatic	
		Other than the above	Manual Operation	Powerful	Setting +2(up)	SLo	—
				Quiet	Setting -1(down)	SLo	—
				Other than the above	Remote control setup	SLo	Remote control setup
	Max. capability			SHi	—	—	

## 2. Heating

		Heating			
Waiting for other mode		Stop			
Forced Operation		SHi			
Min. control	Automatic operation mode judging		Lo-		
Other than the above	During hot start		Stop		
	Under defrosting operation		Stop		
	Ability supply stop		Stop		
	Low-temperature capability measurement		SSH i		
	MAX control	Heating starting force operation		A stop, SLo	
		Ability supply stop		Lo-	
		Thermostat-off sampling		Specification	
		Piping temperature control		Min. Restrictions of fan speed by Indoor pipe temperature	
	Min. control	Fan speed minimum restrictions by Indoor piping temperature		Me	
		Fan Speed automatic minimum		Min. Automatic Fan Speed Control	
	Other than the above	Preparation operation start timer	Automatic Fan Speed		Lo
			Manual Operation	Powerful	Setting +2 (up)
				Quiet	Setting -1 (down)
		Other than the above		Remote control setup	
Other than the above		Fan speed shift control		Heating Fan Speed Control	
		Fan speed automatic	Powerful	Pipe temperature control +2 (up)	
			Quiet	Pipe temperature control -1 (down)	
			Other than the above	Pipe temperature control	
		Fan speed automatic	Powerful	Setting +2 (up)	
			Quiet	Setting -1 (down)	
	Other than the above		Remote control setup		

## ii. Auto Fan Speed

### 1. Cooling

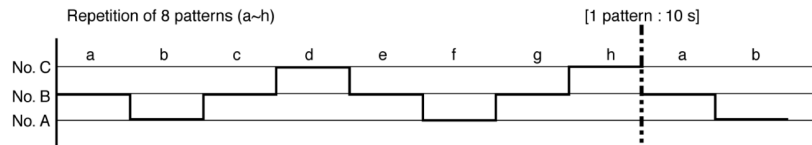

	Model	No. A	No. B	No. C
Powerful Program	CS-ME7DKEG, CS-E9DKEW	1110	1130	1150
	CS-E12DKEW	1230	1250	1270
	CS-E15DKEW	1300	1320	1340
	CS-E18DKEW	1390	1410	1430
Normal Program	CS-ME7DKEG, CS-E9DKEW	1050	1070	1090
	CS-E12DKEW	1170	1190	1210
	CS-E15DKEW	1240	1260	1280
	CS-E18DKEW	1330	1350	1370
Quiet Program	CS-ME7DKEG, CS-E9DKEW	1030	1050	1070
	CS-E12DKEW	1150	1170	1190
	CS-E15DKEW	1220	1240	1260
	CS-E18DKEW	1310	1330	1350

- Refer to the CS-ME7DKEG column for CS-ME7DKDG.
- Refer to the CS-E9DKEW column for CS-E9DKDW.
- Refer to the CS-E12DKEW column for CS-E12DKDW.
- Refer to the CS-E15DKEW column for CS-E15DKDW.
- Refer to the CS-E18DKEW column for CS-E18DKDW.

## 2. Heating

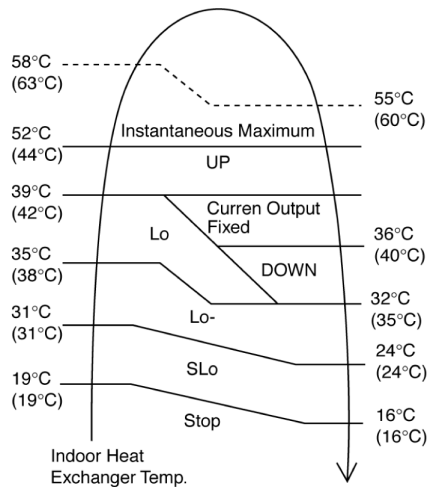

Note:

a. UP:

- If move from Lo, the fan speed will be shifted to Maximum 1,520 rpm.
- If move from Maximum, the fan speed no change.
- In up zone, 10 rpm is added for every 10 seconds until Maximum 1,520 rpm.

b. DOWN:

- The fan speed will be decreased one step every 10 seconds until Minimum 1,270 rpm.

c. Current Output Fixed:

- Maintain at present fan speed.

d. Instantaneous Maximum:

- Fan speed will be increased to maximum auto fan speed.

e. Temperature in ( ) is for Powerful Mode operation.

## C. Fan Motor Control

1. Motor specification

High voltage PWM Motor

2. Feedback Control

a. Number-of -rotations feedback

Immediately after the fan started, rpm is checked and duty is added, and feedback control is performed. For high voltage PWM motor. It is done once every 0.5 seconds.

b. Offset duty T max/min limit

High voltage PWM motor has maximum offset duty.

(Refer to indoor fan motor control basic rotation speed.)

3. Abnormal detection Control

Conditions:

a. Out of rhythm signal input

b. If feedback number of rotations exceeded 2,550 rpm or when less than 50 rpm.

Control: Fans stop.

Return: Restart after 5 seconds.

\* It will not detect out of rhythm condition within 5 seconds for phase control motor (PWM motor is when duty = 0) after start.

A fan stops when condition (1) and (2) happen within 25.0 seconds after fan starting, and if this happens for continuously 7 times, it will not retry.

→ FM lock processing

4. Restart Prohibition Control

Restart is prohibited within 5 seconds for phase control motor (PWM motor is when duty = 0) after dan stop (except re-ON the power supply)

## D. Deodorizing Control

### i. Control condition

Control at cooling/soft dry operation and auto fan speed.

No Deodorizing Control is performed during ON timer standby operation and during freeze prevention control.

### ii. Operation

The odor status is arranged as below and it is shifted as follows.

- \* When COMP is ON 1 → 2 → 3  
(Shift to 4 when COMP is OFF)
- \* When COMP is OFF 4 → 5 → 6 → 7 → 6 ←→ 7  
(Shift to 1 when COMP is ON)
- \* Start from 4 if the Thermostat is OFF during the start operation.

Odor Status		1	2	3	4	5	6	7	6.7.6...	1	
Status Shift according to COMP		ON				OFF					ON
Status Shift according to time (s)	Cooling zone	40	50	—	30	90	20	90	20.90.20...	ON	
	Dry zone										
Fan Speed	Cooling zone	OFF	SSLo	Auto Fan Speed	SSLo	OFF	SSLo	OFF	SSLo.OFF...		
	Dry zone			SLo							

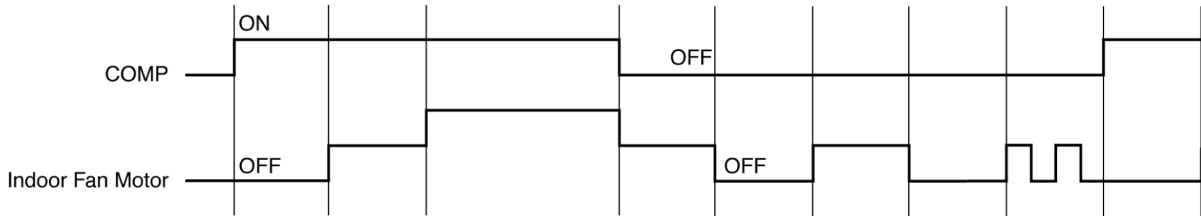

※ During FM OFF state, auto judgement will cause the FM to ON.

## 8.1.1.8. Airflow Direction

- There are two types of airflow, vertical airflow (directed by horizontal vane) and horizontal airflow (directed by vertical vanes).
- Control of airflow direction can be automatic (angles of direction is determined by operation mode, heat exchanger temperature and intake air temperature) and manual (angles of direction can be adjusted using remote control).

### Vertical Airflow

Operation Mode	Airflow Direction		Vane Angle (°)				
			1	2	3	4	5
Heating	Auto with Heat Exchanger Temperature	A Upward fix	3				
		B Downward fix	64				
		C Downward fix	3				
		D Downward fix	3				
	Manual		3	17	33	49	63
Cooling, Soft Dry and Ion	Auto		8 ~ 36				
	Manual		8	15	22	30	36
Mode judgment in Auto	Auto		8				
	Manual		8	15	22	30	36

- Automatic vertical airflow direction can be set using remote control; the vane swings up and down within the angles as stated above. For heating mode operation, the angle of the vane depends on the indoor heat exchanger temperature as Figure 1 below. When the air conditioner is stopped using remote control, the vane will shift to close position.
- Manual vertical airflow direction can be set using remote control; the angles of the vane are as stated above and the positions of the vane are as Figure 2 below. When the air conditioner is stopped using remote control, the vane will shift to close position.

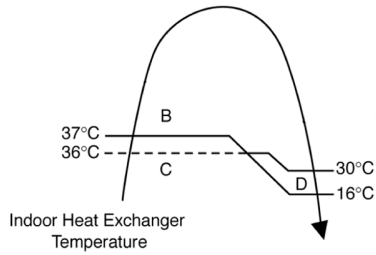

Figure 1

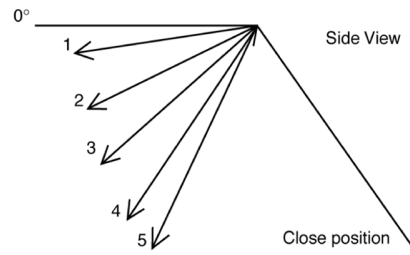

Figure 2

### Horizontal Airflow

1. Automatic horizontal airflow direction can be set using remote control; the vane swings left and right within the angles as stated below. For heating mode operation, the angle of the vane depends on the indoor heat exchanger temperature as Figure 1 below.

Operation Mode		Vane Angle (°)
Heating, with heat exchanger temperature	A	65 ~ 115
	B	90
Cooling, Soft Dry and Ion		65 ~ 115

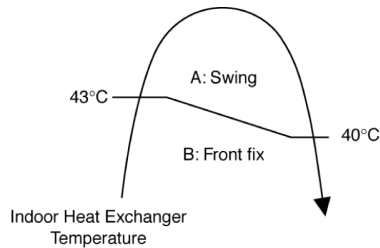

Figure 1

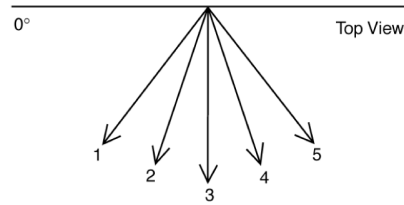

Figure 2

2. Manual horizontal airflow direction can be set using remote control; the angles of the vane are as stated below and the positions of the vane are as Figure 2 above.

Pattern	1	2	3	4	5
Airflow Direction Patterns at Remote Control					
Vane Angle (°)	90	65	78	102	115

### 8.1.1.9. Quiet operation (Cooling Mode/Cooling area of Soft Dry Mode)

#### A. Purpose

To provide quiet cooling operation compare to normal operation.

#### B. Control condition

a. Quiet operation start condition

- When "quiet" button at remote control is pressed.  
Quiet LED illuminates.

b. Quiet operation stop condition

1. When one of the following conditions is satisfied, quiet operation stops:

- Powerful button is pressed.
- Stop by OFF/ON switch.
- Timer "off" activates.
- Quiet button is pressed again.

2. When quiet operation is stopped, operation is shifted to normal operation with previous setting.
3. When fan speed is changed, quiet operation is shifted to quiet operation of the new fan speed.
4. When operation mode is changed, quiet operation is shifted to quiet operation of the new mode.
5. During quiet operation, if timer "on" activates, quiet operation maintains.
6. After off, when on back, quiet operation is not memorised.

### **C. Control contents**

1. Fan speed is changed from normal setting to quiet setting of respective fan speed.  
This is to reduce sound of Hi, Me, Lo for 3dB.
2. Fan speed for quiet operation is -1 step from setting fan speed.

## **8.1.1.10. Quiet operation (Heating)**

### **A. Purpose**

To provide quiet heating operation compare to normal operation.

### **B. Control condition**

#### a. Quiet operation start condition

- When "quiet" button at remote control is pressed.  
Quiet LED illuminates.

#### b. Quiet operation stop condition

1. When one of the following conditions is satisfied, quiet operation stops:
  - a. Powerful button is pressed.
  - b. Stop by OFF/ON switch.
  - c. Timer "off" activates.
  - d. Quiet button is pressed again.
2. When quiet operation is stopped, operation is shifted to normal operation with previous setting.
3. When fan speed is changed, quiet operation is shifted to quiet operation of the new fan speed.
4. When operation mode is changed, quiet operation is shifted to quiet operation of the new mode, except fan only mode.
5. During quiet operation, if timer "on" activates, quiet operation maintains.
6. After off, when on back, quiet operation is not memorised.

### **C. Control contents**

#### a. Fan Speed manual

1. Fan speed is changed from normal setting to quiet setting of respective fan speed.  
This is to reduce sound of Hi, Me, Lo for 3dB.
2. Fan speed for quiet operation is -1 step from setting fan speed.
3. Fan Speed Auto  
Indoor FM RPM depends on pipe temp sensor of indoor heat exchanger.

### 8.1.1.11. Powerful Mode Operation

When the powerful mode is selected, the internal setting temperature will shift to achieve the setting temperature quickly.

(a) Cooling Operation

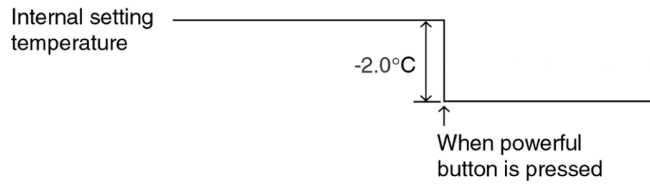

(b) Soft Dry Operation

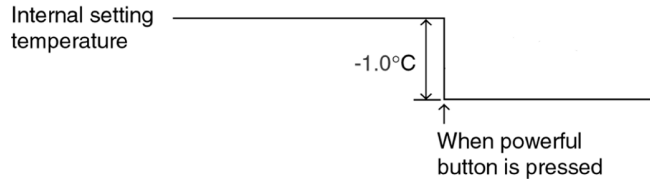

(c) Heating Operation

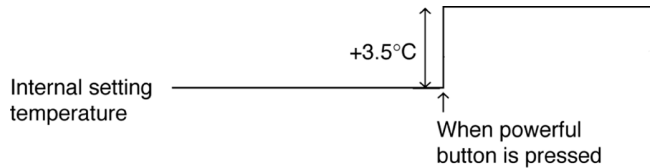

### 8.1.1.12. ON Timer Control

ON timer can be set using remote control, the unit with timer set will start operate earlier than the setting time. This is to provide a comfortable environment when reaching the set ON time.

60 minutes before the set time, indoor (at fan speed of Lo-) and outdoor fan motor start operate for 30 seconds to determine the indoor intake air temperature and outdoor air temperature in order to judge the operation starting time.

From the above judgment, the decided operation will start operate earlier than the set time as shown below.

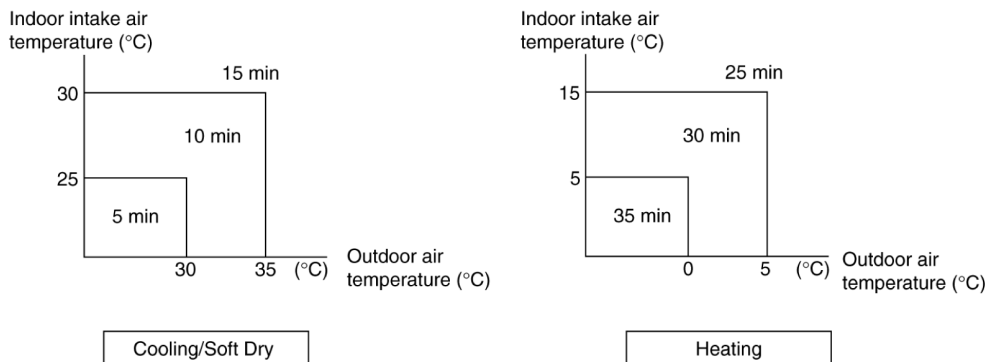

### 8.1.1.13. OFF Timer Control

OFF timer can be set using remote control, the unit with timer set will stop operate at set time.

### 8.1.1.14. Auto Restart Control

- If there is a power failure, operation will automatically be restarted when the power is resumed. It will start with the previous operation mode and airflow direction. (Timer Delay Safety Control is valid.)

#### 1. Control start conditions

- The 24-hour timer must not be set.
- The sleep timer must not be set.

Auto start control is not available when timer or sleep mode is set.

#### 2. Description of control

- In the case of manual operation, the operation mode, temperature setting, fan speed and airflow direction before the power is turned off are restored.
- In the case of automatic operation, after the power is restored operation starts with the determination of the mode.
- While the air conditioner odour clear timer has been set, the setting is cancelled, and operation is transferred to the mode before the power is turned off.
- While the air conditioner odour clear operation (with timer / without timer setting) are being performed, both of these operations are completed, and operation is transferred to the operation mode prior to these operations.

Example: When the power is turned off during an outdoor unit cooling operation.

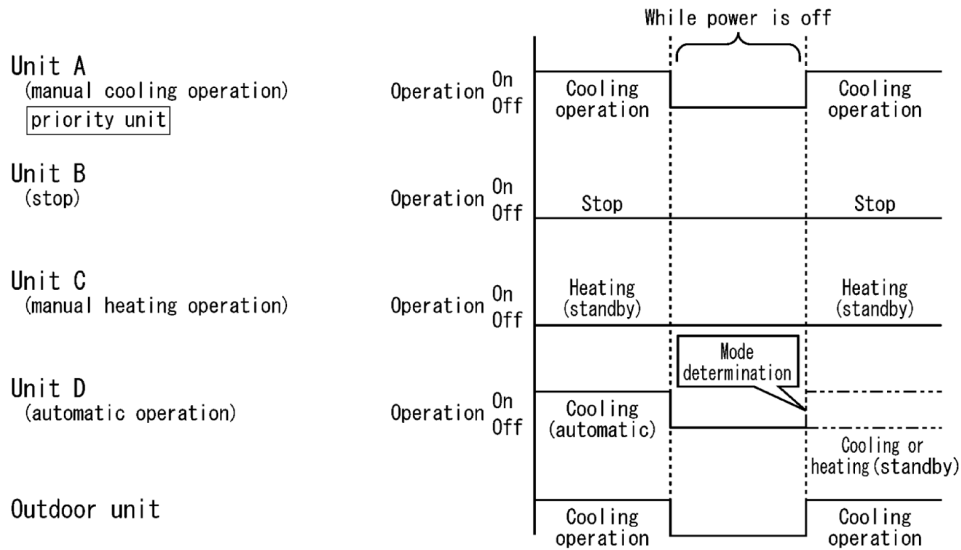

### 8.1.1.15. Indication Panel

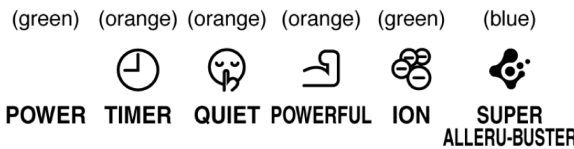

LED	POWER	TIMER	QUIET	POWERFUL	ION	ALLERGEN BUSTER
Color	Green	Orange	Orange	Orange	Green	Blue
Light ON	Operation ON	Timer Setting ON	Quiet Mode ON	Powerful Mode ON	Ion Mode ON	Operation ON
Light OFF	Operation OFF	Timer Setting OFF	Quiet Mode OFF	Powerful Mode OFF	Ion Mode OFF	Operation OFF

#### Note:

- If POWER LED is blinking, the possible operations of the unit are Hot Start, during Deice operation, operation mode judgment, or delay ON timer sampling.
- If timer LED is blinking, there is an abnormality operation occurs.
- If ionizer LED is blinking, there is an abnormality of ionizer occurs.

### 8.1.1.16. Auto Operation Switch

Number of "beep":	1	2	3	4
Function:	Auto Operation	Forced Cool	Forced Heat	Various Setting Mode
Duration (s):	0	5	8	11
				16
				21

1. When the switch is pressed between 0 to 5 seconds, Auto Mode operation starts to function.
2. When the switch is pressed between 5 to 8 seconds, the unit is forced to operate in Cooling Mode.
3. When the switch is pressed between 8 to 11 seconds, the unit will enter forced Heating Mode standby. Press timer decrement button for 5s for the unit to operate in Heating Mode.
4. When the switch is pressed between 11 to 16 seconds and together with the signal from remote control (timer decrement button for 5s), the unit can be changed to different controlling setting (4 type of transmission codes).
5. When the switch is pressed between 16 to 21 seconds, either "H14" error detection selection mode or the remote control signal receiving sound can be cancelled or turned on.

### 8.1.1.17. Ionizer Operation

#### Purpose

To provide fresh air effect to users by discharging minus ion to air.

#### Control Condition

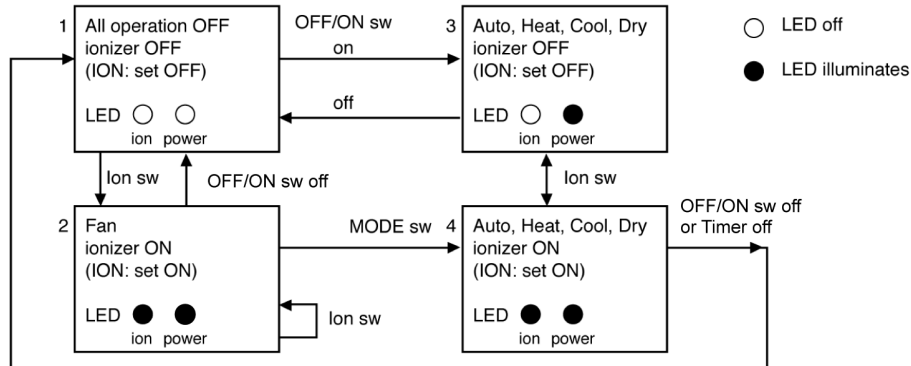

#### a. Ionizer Only Operation.

1. When air-conditioner unit is at "OFF" condition (standby) and ION operation button at remote control is pressed. Fan & ionizer on, ION LED illuminates, ION and power LEDs illuminate. (1 → 2)  
 However, fan speed can be adjusted later by customer during this operation.

Fan speed	
manual	Remote Control set fan speed
Auto	Repetition of 8 patterns as shown below

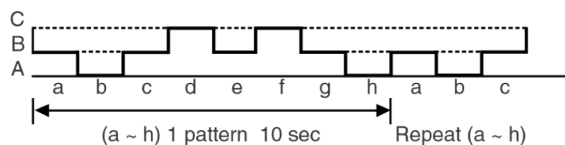

Airflow direction (Horizontal Vane) control:

Follow vane direction control at cooling mode.

Horizontal vane can be changed by customer during ion only operation.

b. Operation Mode + Ionizer Operation.

1. Ionising Operation Start Condition

When air conditioner unit is in "ON" condition (Heat, Cool, Dry, Fan, Auto mode) and an ION operation button at remote control is pressed. Ionizer on & ION LED illuminates. (3 → 4)

Power LED also illuminates.

2. Ionising Operation Stop Condition

When one of the following conditions is satisfied, ION operation stops.

a. Stopped by ON/OFF switch.

b. Timer OFF activates.

c. ION feedback signal shows error.

3. When "ION" is displayed on the remote controller, Ionizer operates.

c. Timer during ionizer operation

Refer to case study in next page for details.

### 8.1.1.17.1. Ionizer Problem Detection Control

i. Purpose

To inform user of ionizer problems and detection.

ii. Two types of problem detection control:

Control	Detection Method	Protection	Recovery
<p><b>ERROR PROTECTION</b></p> <p>(i) Actual ion: ON</p> <p>(ii) ion feedback signal: 0V</p>	<p>(i) Actual ion ON for 10s &amp; OFF for 30 min. continuously for 24 times (approx. 11 hr. 30 min.)</p> <p>(ii) Within 24 counts, if anytime CONDITION becomes false then count is cleared.</p>	<p>(i) Actual ion is permanently OFF &amp; ion LED is blinking.</p> <p>(ii) Press remote control ion button for a) ON: Ion LED blink &amp; buzzer = beep b) OFF: Ion LED OFF &amp; buzzer = beep</p>	<p>(i) Press ON/OFF button to OFF</p> <p>(ii) Reset power</p> <p>(iii) Off by force operation</p>
<p><b>BREAKDOWN PROTECTION</b></p> <p>(i) Actual ion: OFF</p> <p>(ii) ion feedback signal: 5V</p>	<p>(i) Actual ion OFF <math>\geq</math> 2s</p>	<p>Case 1: During Air-Con. ON.</p> <p>(i) Air-Cond OFF with abnormal no. H26 is activated with timer LED is blinking permanently.</p> <p>Case 2: During Air-Con. OFF.</p> <p>(i) Abnormal no. H26 is activated with timer LED is blinking permanently for both cases 1 &amp; 2.</p> <p>(ii) Press remote control ion button for a) ON: Ion LED blink b) OFF: Ion LED OFF</p> <p>(iii) Press any remote control button to a) ON: Buzzer = beep beep beep beep b) OFF: Buzzer = beep beep beep beep</p>	<p>(i) When anytime CONDITION becomes false.</p> <p>(ii) Once recovered, ion &amp; Timer LED stops blinking permanently.</p> <p>(iii) Main power reset.</p>

### 8.1.1.17.2. Ionizer Operation case study

Case 1

Current Operation	Timer	24 hours Timer	
		Set to ON	Set to OFF
ION	ON	Continue ON	Stop
	OFF	Not Applicable (*2)	Continue OFF
Operation Any Mode (*1)	ON	Continue ON	Stop
	OFF	Start	Stop

### 8.1.2. Freeze Prevention Control

1. When indoor heat exchanger temperature is lower than 2°C continuously for six minutes, compressor will stop operating.
2. Compressor will resume its operation three minutes after the indoor heat exchanger is higher than 10°C.
3. At the same time, indoor fan speed increase +20 rpm compared to its normal operation.
4. If indoor heat exchanger temperature is higher than 10°C for five minutes, the fan speed will return to its normal operation.

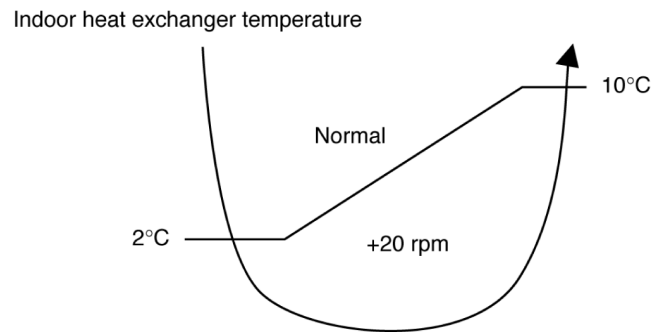

## 8.2. Duct Type

### 8.2.1. Simultaneous Operation Control

**1. Operation modes which can be selected using the remote control unit:**

Automatic, Cooling, Soft Dry, Heating, Fan operation mode.

**2. Types of operations modes which can be performed simultaneously**

- Cooling operation and cooling, Soft Dry or fan operation
- Heating operation and heating operation

**3. Types of operation modes which cannot be performed simultaneously**

- While a cooling operation is in progress, a heating operation cannot be performed by an indoor unit in another room.

In the room where the operation button for cooling was pressed first, the operation is continued. In the room where the operation button for heating was pressed afterward, the operation lamp of the indoor unit blinks, where the attempt is made to establish the heating operation. Its fan is stopped, and the air does not discharged.

- While a heating operation is in progress, a cooling operation cannot be performed by an indoor unit in another room.

In the room where the operation button for heating was pressed first, the operation is continued. In the room where the operation button for cooling was pressed afterward, the operation lamp of the indoor unit blinks, where the attempt is made to establish the cooling operation. Its fan is stopped, and the air does not discharged.

**4. Operation mode priority control**

- The operation mode designated first by the indoor unit has priority.
- If the priority indoor unit stops operation or initiates the fan operation, the priority is transferred to other indoor units.

“Waiting” denotes the standby status in which the operation lamp LED blinks (ON for 2.5 sec. and OFF for 0.5 sec.), and the fan is stopped.

		B ROOM					
		Non Priority Unit (2nd. ON)					
A ROOM Priority Unit (1st. ON)	Cooling	C	C	D	Waiting	C	F
	Soft Dry	D	C	D	D	Waiting	F
	Heating	H	Waiting	H	Waiting	H	Stop
	Fan *	F	C	F	D	Stop	H

\* In the fan mode, priority is transferred to a non-priority unit.

**Note**

- C: Cooling operation mode
- D: Soft Dry operation mode
- H: Heating operation mode
- F: Fan operation mode

## 8.2.2. Indoor Fan Control

- The following shows how fan speed changes depending on the setting made with the FAN SPEED button and other operating conditions.
- Actual fan speed may differ from that you set with remote control.

《CS-ME10DD3EG》

Rotation Speed		Stop	~	~	~ 750	~ 750	~ 800	~ 900	~ 980	~ 1060	~ 1140	~ 1230	~ 1260	~ 1350								
Cooling	Manual				SSLo	SLo	Lo-	Low	●Me-	Me	●Me+	Hi	SHi	PSHi								
	Auto	○		○				⊗※1	⊗※2	⊗	⊗											
	Powerful	○							⊗※1	⊗※2	⊗	⊗										
	Quiet	○					⊗※1	⊗※2	○	~	○											
Soft Dry	Manual	⊙			SSLo	SLo	Lo-	Low	●Me-	Me	●Me+	Hi	SHi	PSHi								
	Auto	○		○				⊗※1	⊗※2	⊗	⊗											
Rotation Speed(rpm)		Stop	~	750	~	750	~	800	~	900	~	1010	~	1130	~	1250	~	1370	~	1430	~	1450
Heating	Manual				SSLo	SLo		Low	●Me-	Me	●Me+	Hi	SHi	PSHi								
	Auto	○	○	○	○			⊗	⊗	⊗	⊗	⊗	⊗	⊗								
	Powerful	○						⊗	⊗	⊗	⊗	⊗	⊗	⊗								
	Quiet	○						⊗	⊗	⊗	⊗	⊗	⊗	⊗								

"⊙" fan speed is set automatically. "○" in Cooling indicates that fan speed and deodorizing are controlled together.  
"○" in Heating indicates that fan speed, hot start and anti-cold draft are controlled together.

Remarks:  Remote control settings.

※1 When difference between intake air temperature and internal set temperature is +0.5°C and below.

※2 When difference between intake air temperature and internal set temperature is +1.5°C and below.

When difference between intake air temperature and internal set temperature is +1.5°C and above.

《CS-E15DD3EW》

Rotation Speed(rpm)		Stop	~	~	~ 750	~ 750	~ 800	~ 900	~ 1000	~ 1100	~ 1200	~ 1300	~ 1330	~ 1350								
Cooling	Manual				SSLo	SLo	Lo-	Low	●Me-	Me	●Me+	Hi	SHi	PSHi								
	Auto	○		○				⊗※1	⊗※2	⊗	⊗											
	Powerful	○							⊗※1	⊗※2	⊗	⊗										
	Quiet	○					⊗※1	⊗※2	○	~	○											
Soft Dry	Manual	⊙			SSLo	SLo	Lo-	Low	●Me-	Me	●Me+	Hi	SHi	PSHi								
	Auto	○		○				⊗※1	⊗※2	⊗	⊗											
Rotation Speed		Stop	~	750	~	750	~	900	~	980	~	1070	~	1170	~	1270	~	1370	~	1430	~	1450
Heating	Manual				SSLo	SLo		Low	●Me-	Me	●Me+	Hi	SHi	PSHi								
	Auto	○	○	○	○			⊗	⊗	⊗	⊗	⊗	⊗	⊗								
	Powerful	○						⊗	⊗	⊗	⊗	⊗	⊗	⊗								
	Quiet	○						⊗	⊗	⊗	⊗	⊗	⊗	⊗								

"⊙" fan speed is set automatically. "○" in Cooling indicates that fan speed and deodorizing are controlled together.  
"○" in Heating indicates that fan speed, hot start and anti-cold draft are controlled together.

Remarks:  Remote control settings.

※1 When difference between intake air temperature and internal set temperature is +0.5°C and below.

※2 When difference between intake air temperature and internal set temperature is +1.5°C and below.

When difference between intake air temperature and internal set temperature is +1.5°C and above.

《CS-E18DD3EW》

Rotation Speed(rpm)		Stop	~	~	~ 800	~ 800	~ 900	~ 1020	~ 1140	~ 1260	~ 1380	~ 1500	~ 1550	~ 1600								
Cooling	Manual				SSLo	SLo	Lo-	Low	●Me-	Me	●Me+	Hi	SHi	PSHi								
	Auto	○		○				⊗※1	⊗※2	⊗	⊗											
	Powerful	○							⊗※1	⊗※2	⊗	⊗										
	Quiet	○					⊗※1	⊗※2	○	~	○											
Soft Dry	Manual	⊙			SSLo	SLo	Lo-	Low	●Me-	Me	●Me+	Hi	SHi	PSHi								
	Auto	○		○				⊗※1	⊗※2	⊗	⊗											
Rotation Speed		Stop	~	800	~	800	~	1080	~	1200	~	1300	~	1400	~	1500	~	1600	~	1650	~	1700
Heating	Manual				SSLo	SLo		Low	●Me-	Me	●Me+	Hi	SHi	PSHi								
	Auto	○	○	○	○			⊗	⊗	⊗	⊗	⊗	⊗	⊗								
	Powerful	○						⊗	⊗	⊗	⊗	⊗	⊗	⊗								
	Quiet	○						⊗	⊗	⊗	⊗	⊗	⊗	⊗								

"⊙" fan speed is set automatically. "○" in Cooling indicates that fan speed and deodorizing are controlled together.  
"○" in Heating indicates that fan speed, hot start and anti-cold draft are controlled together.

Remarks:  Remote control settings.

※1 When difference between intake air temperature and internal set temperature is +0.5°C and below.

※2 When difference between intake air temperature and internal set temperature is +1.5°C and below.

When difference between intake air temperature and internal set temperature is +1.5°C and above.

### 8.2.3. Drain Pump Control

#### Basic operation

- The drain pump starts 50 seconds after the indoor unit starts or the thermostat comes on (i.e., 10 seconds after the fan motor starts).  
The drain pump stops 30 seconds after the indoor unit stops or the thermostat turns off.
- The drain pump repeats a cycle of on for 30 seconds then off for between 50 and 90 seconds as long as the unit is operating. Operation while the unit is off is determined by the difference between the temperature setting and the room temperature.

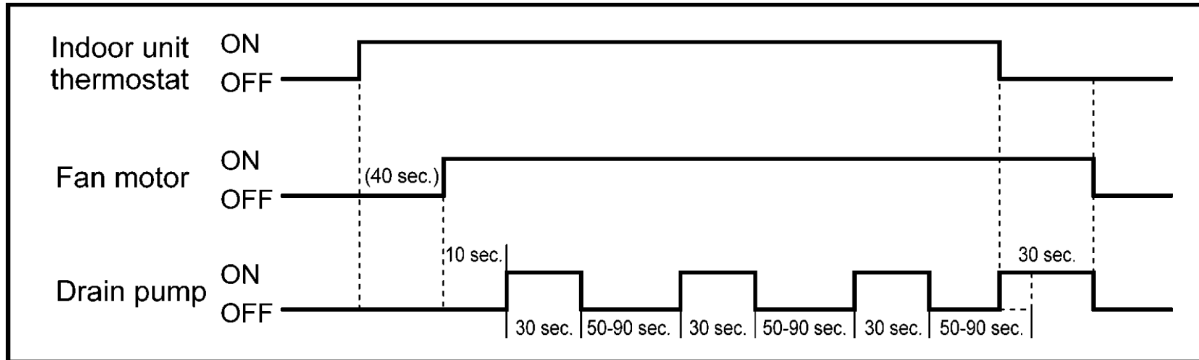

#### Float switch operation

- When the float switch turns on for 10 seconds continuously, the thermostat of the indoor unit turns off and the drain pump operates continuously.
- When the float switch stays on for 150 seconds continuously, the drain pump and indoor unit stop and the timer lamp flashed indicating an H21 error.

## 8.2.4. Auto Restart Control

- If there is a power failure, operation will automatically be restarted when the power is resumed. It will start with the previous operation mode and airflow direction. (Timer Delay Safety Control is valid.)

### 1. Control start conditions

- The 24-hour timer must not be set.
- The sleep timer must not be set.

Auto start control is not available when timer or sleep mode is set.

### 2. Description of control

- In the case of manual operation, the operation mode, temperature setting, fan speed and airflow direction before the power is turned off are restored.
- In the case of automatic operation, after the power is restored operation starts with the determination of the mode.
- While the air conditioner odour clear timer has been set, the setting is cancelled, and operation is transferred to the mode before the power is turned off.
- While the air conditioner odour clear operation (with timer / without timer setting) are being performed, both of these operations are completed., and operation is transferred to the operation mode prior to these operations.

Example: When the power is turned off during an outdoor unit cooling operation.

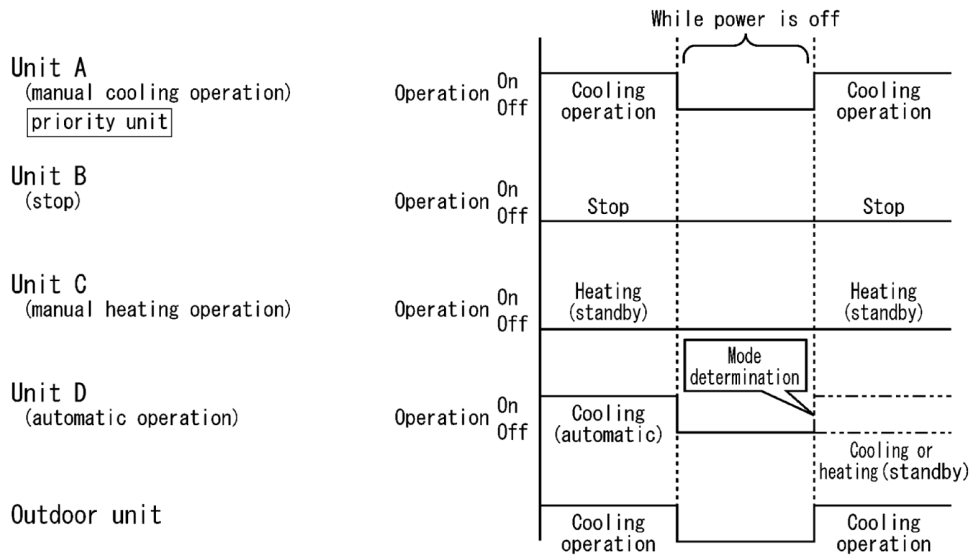

## 8.2.5. Other Indoor Unit Operation Functions

### 8.2.5.1. Auto button

Proceed with operation when the air conditioner is stopped.

(When the auto button is pressed during operation, the air conditioner is stopped.)

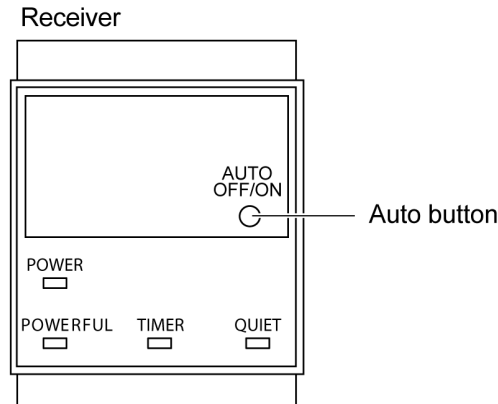

#### 1. Emergency operation

Press the auto button and release it within 5 seconds to perform emergency operation.

Under normal condition (failure is not occurred) automatic operation is performed. In the event of a failure that still enables operation to be performed, emergency operation is performed.

#### 2. Forced cooling operation

press the auto button about 5-8 seconds (1 beep sound) to perform the forced cooling operation.

**The air conditioner does not operate for 2 minutes if the room temperature is low (intake temperature below 16°C) so just wait. The forced operation is performed after 2 minutes have elapsed.**

#### 3. Forced heating operation

Press the auto button about 8-11 seconds (2 beeps sound) to perform the forced heating operation.

#### 4. Setting modes (Remote control transmission code, current switching mode)

The remote control transmission code selection mode is established by pressing the AUTO button about 11-16 seconds (3 beeps sound).

Remote control transmission code selection ... remote control unit no.A (beep) ↔ remote control unit no.B (extended beep)  
(Auto button operation)

#### Select Remote Control Transmission Code

- There are 4 types of remote control transmission code could be selected and stored in EEPROM of indoor unit. The indoor unit will only operate when received signal with same transmission code from remote control. This could prevent signal interference when there are 2 more indoor unit installed nearby together.
- To change remote control transmission code, short or open jumpers at the remote control printed circuit board.

Remote Control Printed Circuit Board	Transmission Code Combination		
	J - A	J - B	Remote Control No.
<p>The diagram shows a printed circuit board with two jumpers, J-A and J-B, connected to specific points on the board. The board is labeled 'UR7BPB1.306A'.</p>	Short	Open	A (Default)
	Open	Open	B
	Short	Short	C
	Open	Short	D

- Under various setting mode, after select the transmission code combination of remote control, press any button of remote control to transmit a signal to indoor unit. The transmission code will be stored in EEPROM.
- After signal is received, the various setting mode is cancelled and return to normal operation.

### 5. Individual setting mode

The H14 error detection selection mode is established by pressing the auto button about 21 seconds (5 beeps sound). Now remove the remote control unit's battery cover, and short the "SET" terminals to established the beep sound mode.

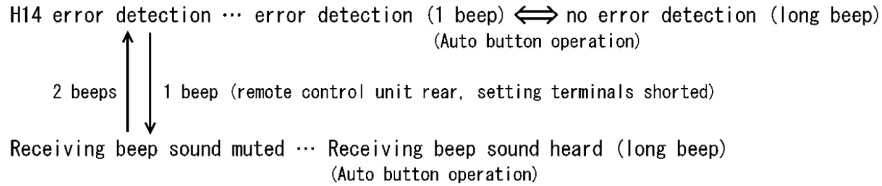

**\*If the auto button is pressed and 26 seconds or so are allowed to elapse, the auto button operation mode is restored.**  
**When nothing happens for 60 seconds in the "Setting mode", "Odour clear setting mode" or "Individual setting mode" or if a remote control code is received, the mode concerned is canceled.**

### 8.2.5.2. Drain Test (SW1)

When installing the unit and you want the Drain pump to operate independently, press the DRAIN TEST switch to operate it for about 5 minutes.

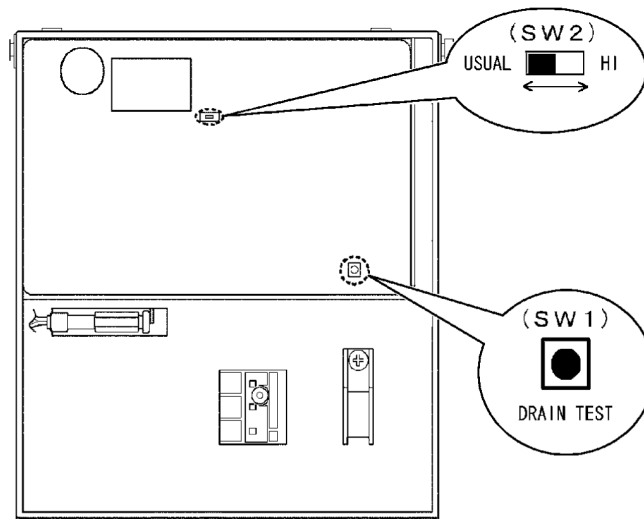

### 8.2.5.3. High Static Pressure Switch (High state switch SW2)

To increase the fan speed, open the control box and the control board switch the HIGH STATE switch (SW2) to "HI".

## 8.3. Ceiling Floor Type

### 8.3.1. Basic Function

Inverter control, which equipped with a microcomputer in determining the most suitable operating mode as time passes, automatically adjusts output power for maximum comfort always. In order to achieve the suitable operating mode, the microcomputer maintains the set temperature by measuring the temperature of the environment and performing temperature shifting. The compressor at outdoor unit is operating following the frequency instructed by the microcomputer at indoor unit that judging the condition according to internal setting temperature and intake air temperature.

#### 8.3.1.1. Internal Setting Temperature

Once the operation starts, remote control setting temperature will be taken as base value for temperature shifting processes. These shifting processes are depending on the air conditioner settings and the operation environment. The final shifted value will be used as internal setting temperature and it is updated continuously whenever the electrical power is supplied to the unit.

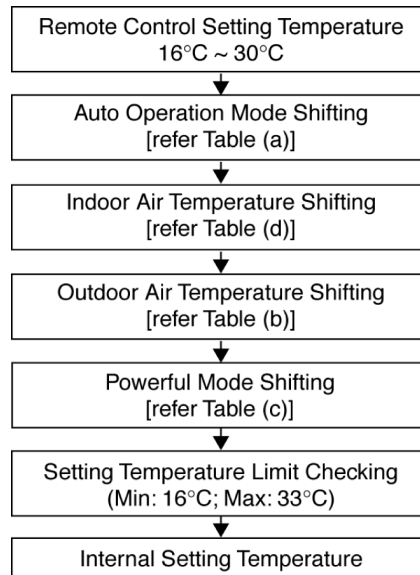

**Table (a): Auto Operation Mode Setting**

Mode Shift:	Temperature Shift (°C)
Cooling/Soft Dry → Heating	-2.0
Heating → Cooling/Soft Dry	+2.0

**Table (b): Outdoor Air Temperature Shifting**

Mode:	Outdoor Temperature, X (°C):	Temperature Shift (°C)
Cooling/Soft Dry	$30 \leq X$	+0.5
	$X < 30$	+1.0
Heating	$9 \leq X$	-1.0
	$5 \leq X < 9$	-0.5
	$1 \leq X < 5$	0.0
	$X \leq 1$	+1.0

**Table (c): Power Mode Shifting**

Mode:	Temperature Shift (°C)
Cooling	-4.0
Soft Dry	-2.0
Heating	+6.0

**Table (d): Indoor Air Temperature Shifting**

1. Target room temperature shift value (dGetaDst)

- To offset the absolute gap between detection temperature with actual room temperature.
- The heat exchanger unit's temperature is different based on operation mode, it becomes the action operation mode value.

Actual operation mode	Target room temperature offset value (dGetaDst)
Cooling	(1)
Heating	(2)
Soft Dry	(0)

2. Room temperature shift value (dGeta)

- When compressor ON/OFF, correction of detected room temperature by shift value during defrost etc.
  - i) Initial value when operation starts, or changing the actual operation mode.

Set the offset value at each operation mode. However, in order to improve the heating startup efficiency, the offset value will be changed based on the gap between setting temperature and room temperature.

Actual operation mode	Gap between setting temperature and room temperature	Room temperature offset value (dGeta)
Cool	—	(0)
Heat	(Operation start set temp. - room temp.) < 4°C	(4)
	(Operation start set temp.) ≥ 4°C	(4)
Soft Dry	—	(0)

ii) Updating during operation

During operation, it will compare with the target room temperature offset value at specific period, then the room temperature will be updated.

Actual operation mode	Room temperature zone	Updating period (sec.)
Cool	—	(180)
Heat	A, B, C, D zone	(15)
Soft Dry	—	(180)

Update the room temperature offset value (dGeta)

Temperature condition	Room temp. offset value after modified (dGeta)
Target room temp. offset value > Room temp. offset value (dGetaDst > dGeta)	dGeta + (0.5)
Target room temp. offset value < Room temp. offset value (dGetaDst < dGeta)	dGeta - (0.5)
Target room temp. offset value = Room temp. offset value (dGetaDst = dGeta)	Do not change.

However, if the following condition is occurred, temperature cannot detect correctly and therefore no updating will be done.

- Heating zone E and above (Temperature gap is big and great capacity increased.)
- During deice
- After deice complete \*within 600 sec.
- Comp. stop
- Comp. starting \*within 600 sec.

**Table (e)**

Installation position change heating shift	-4°C
--	------

### 8.3.1.2. Simultaneous Operation Control

**1. Operation modes which can be selected using the remote control unit:**

Automatic, Cooling, Soft Dry, Heating, Fan operation mode.

**2. Types of operations modes which can be performed simultaneously**

- Cooling operation and cooling, Soft Dry or fan operation
- Heating operation and heating operation

**3. Types of operation modes which cannot be performed simultaneously**

- While a cooling operation is in progress, a heating operation cannot be performed by an indoor unit in another room.

In the room where the operation button for cooling was pressed first, the operation is continued. In the room where the operation button for heating was pressed afterward, the operation lamp of the indoor unit blinks, where the attempt is made to establish the heating operation. Its fan is stopped, and the air does not discharged.

- While a heating operation is in progress, a cooling operation cannot be performed by an indoor unit in another room.

In the room where the operation button for heating was pressed first, the operation is continued. In the room where the operation button for cooling was pressed afterward, the operation lamp of the indoor unit blinks, where the attempt is made to establish the cooling operation. Its fan is stopped, and the air does not discharged.

**4. Operation mode priority control**

- The operation mode designated first by the indoor unit has priority.
- If the priority indoor unit stops operation or initiates the fan operation, the priority is transferred to other indoor units.

“Waiting” denotes the standby status in which the operation lamp LED blinks (ON for 2.5 sec. and OFF for 0.5 sec.), and the fan is stopped.

A ROOM \ B ROOM		Non Priority Unit (2nd. ON)			
		Cooling	Soft Dry	Heating	Fan
Priority Unit (1st. ON)	Cooling	C C	C D	C Waiting	C F
	Soft Dry	D C	D D	D Waiting	D F
	Heating	Waiting H	Waiting H	H H	H Stop
	Fan *	F C	F D	Stop H	F F

\* In the fan mode, priority is transferred to a non-priority unit.

**Note**

- C: Cooling operation mode
- D: Soft Dry operation mode
- H: Heating operation mode
- F: Fan operation mode

### 8.3.1.3. Cooling Operation

#### 8.3.1.3.1. Thermostat control

- Compressor is OFF when Intake Air Temperature - Internal Setting Temperature < -1.5°C.
- Compressor is ON after waiting for 3 minutes, if the Intake Air Temperature - Internal Setting Temperature > Compressor OFF point.

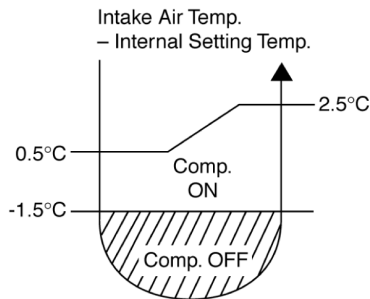

### 8.3.1.4. Soft Dry Operation

#### 8.3.1.4.1. Thermostat control

- Compressor is OFF when Intake Air Temperature - Internal Setting Temperature < -2.0°C.
- Compressor is ON after waiting for 3 minutes, if the Intake Air Temperature - Internal Setting Temperature > Compressor OFF point.

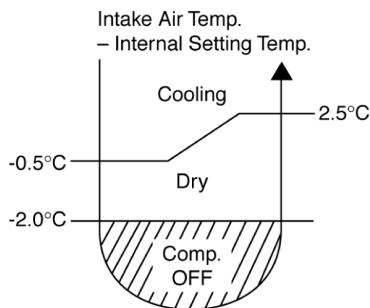

### 8.3.1.5. Heating Operation

#### 8.3.1.5.1. Thermostat control

- Compressor is OFF when Intake Air Temperature - Internal Setting Temperature < +2.0°C.
- Compressor is ON after waiting for 3 minutes, if the Intake Air Temperature - Internal Setting Temperature > Compressor OFF point.

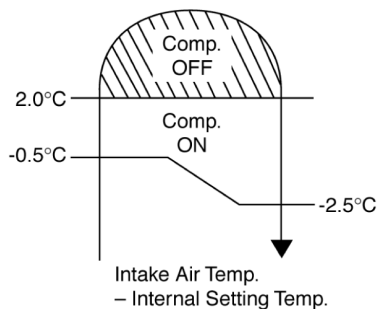

### 8.3.1.6. Automatic Operation

This mode can be set using remote control and the operation is decided by remote control setting temperature, indoor intake air temperature and outdoor air temperature.

During operation mode judgment, indoor fan motor (with speed of Lo-) and outdoor fan motor are running for 30 seconds to detect the indoor intake and outdoor air temperature. The operation mode is decided based on below chart.

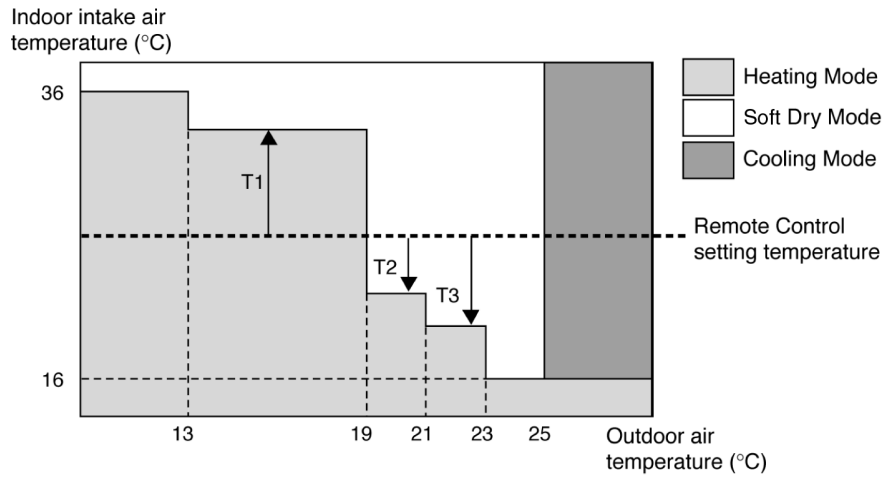

Values of T1, T2, and T3 depend on remote control setting temperature, as shown in below table. After the adjustment of T1, T2 and T3 values, the operation mode for that particular environment and remote control setting is judged and performed, based on the above operation mode chart, every 30 minutes.

Remote Control Setting Temperature (°C)	T1	T2	T3
16 ~ 18	+10	-3	-5
19 ~ 22	+8	-3	-7
23 ~ 26	+7	-3	-7
27 ~ 30	+6	-3	-8

There is a temperature shifting on T1, T2, and T3 if the operation mode judged is changed from Cooling/Dry to Heating or vice verse.

Operation Mode change from	Temperature shifts (°C)
Cooling/Soft Dry → Heating	-2
Heating → Cooling/Dry	+2

Example of operation mode chart adjustment:

From the above table, if remote control setting temperature = 25,

$T1 = 25 + 7 = 32$ ;  $T2 = 25 - 3 = 22$ ;  $T3 = 25 - 7 = 18$

The operation mode chart for this example is as shown in below figure and the operation mode to be performed will depend on indoor intake air temperature and outdoor air temperature at the time when the judgment is made.

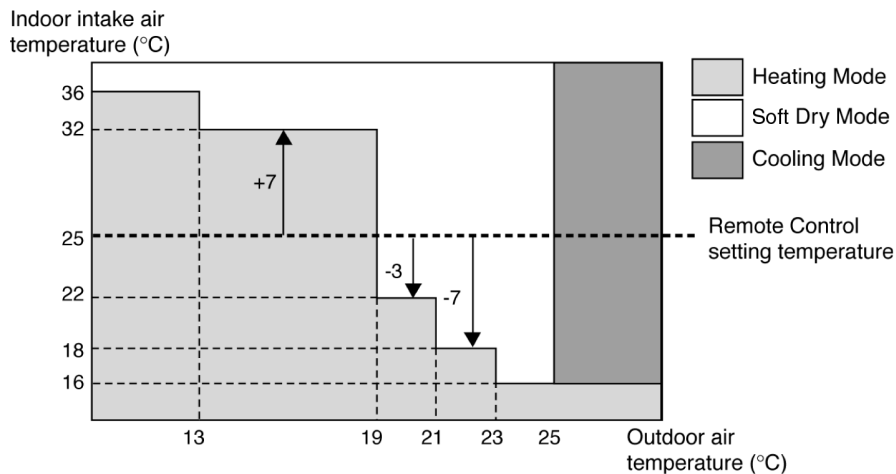

### 8.3.1.7. Indoor Fan Motor Operation

#### A. Basic Rotation Speed (rpm)

- Required rotation speed for fan is set to respond to the remote control setting (10 rpm unit)

#### [Cooling, Soft Dry, Fan]

Remote Control	—	—	O	O	O	O	O	—	—	—
Tab (rpm)	PSHi	SHi	Hi	Me+	Me	Me-	Lo	Lo-	SLo	SSLo
CS-ME10DTEG	900	900	830	790	740	690	640	590	530	370
CS-E15DTEW	1070	1070	1000	940	870	800	730	680	630	370
CS-E18DTEW	1110	1110	1040	970	920	850	790	740	630	370

#### [Heating]

Remote Control	—	—	O	O	O	O	O	—	—	—
Tab (rpm)	PSHi	SHi	Hi	Me+	Me	Me-	Lo	Lo-	SLo	SSLo
CS-ME10DTEG	900	900	830	780	730	680	630	590	530	370
CS-E15DTEW	1080	1080	1010	920	830	730	630	590	530	300
CS-E18DTEW	1110	1110	1050	950	860	770	680	630	540	370

## B. Indoor Fan Control

### i. Indoor fan control operation outline

#### 1. Cooling / Soft Dry

		Cooling	Soft Dry	Ionizer			
Under different mode standby		Stop					
Forced Operation		Hi	—	—			
SEER Measurement mode	The minimum capability	Lo	—	—			
	Middle capability	Hi	—	—			
	Standard rating capacity (rated capability)	Hi	—	—			
Other than above	Min. control	Automatic operation mode judgement					
	Other than above	Freeze proofing		Designated air flow shift	Designated air flow shift	—	
		With dew		Designated air flow shift	Designated air flow shift	—	
	Other than above	Operation	—		—	—	
			Automatic operation		Lo	SLo	Usually, automatic
			Manual Operation	Powerful	Setting +2UP		—
		Quiet		Setting -1down	—		
		Other than the above		Remote control setup	Remote control setup		
		Other than the above	Automatic Operation	Powerful	Powerful automatic	SLo	—
				Quiet	Quiet automatic	—	
			Other than the above	Usually, automatic	SLo	Usually, automatic	
		Other than the above	Manual Operation	Powerful	Setting +2UP	SLo	—
				Quiet	Setting -1down	SLo	—
	Other than the above			Remote control setup	SLo	Remote control setup	
MAX capability		SHi	—	—			

2. Heating

		Heating			
Waiting for other mode		Stop			
Forced Operation		SHi			
SEER Measurement mode		The minimum capability	Lo		
		Middle capability	SHi		
		Rated capability	SHi		
Min. control	Automatic operation mode judging		Lo-		
Other than above	During hot start		Stop		
	Under defrosting operation		Stop		
	Ability supply stop		Stop		
	Low-temperature capability measurement		SSH i		
	MAX control	Heating starting force operation		A stop, SLo	
		Ability supply stop		Lo-	
		Thermostat-off sampling		Specification	
		Piping temperature control		min Restrictions of fan speed by indoor pipe temperature	
	Min control	Fan speed minimum restrictions by indoor piping temperature		Me	
		Fan speed automatic minimum		Auto Fan Speed min Control	
	Other than above	Preparation operation start timer.	Fan speed automatic		Lo
			Manual Operation	Powerful	Setting +2UP
				Quiet	Setting -1down
		Other than the above		Remote control setup	
		Other than above	Fan speed shift control		Heating Fan Speed Control
Fan speed automatic			Powerful	Pipe temperature control +2UP	
			Quiet	Pipe temperature control -1down	
			Other than the above	Piping temperature control	
Fan speed manual			Powerful	Setting +2UP	
			Quiet	Setting -1down	
			Other than the above	Remote control setup	

ii. Auto Fan Speed

1. Cooling

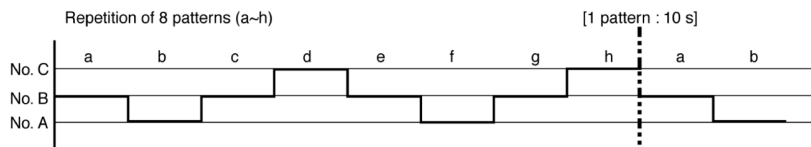

	Model	No. A	No. B	No. C
Powerful Program	CS-ME10DTEG	790	810	830
	CS-E15DTEW	940	960	980
	CS-E18DTEW	990	1010	1030
Normal Program	CS-ME10DTEG	730	750	770
	CS-E15DTEW	880	900	920
	CS-E18DTEW	930	950	970
Quiet Program	CS-ME10DTEG	710	730	750
	CS-E15DTEW	860	880	900
	CS-E18DTEW	910	930	950



Odor Status		1	2	3	4	5	6	7	6.7.6...	1
Status Shift according to COMP		ON			OFF					ON
Status Shift according to time (s)	Cooling zone	40	50	—	30	90	20	90	20.90.20...	ON
	Dry zone									
Fan Speed	Cooling zone	OFF	SSLo	Auto Fan Speed	SSLo	OFF	SSLo	OFF	SSLo.OFF...	
	Dry zone			SLo						

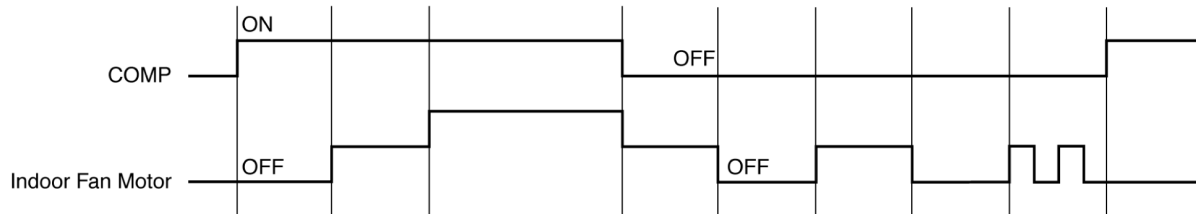

※ During FM OFF state, auto judgement will cause the FM to ON.

### 8.3.1.8. Airflow Direction

1. There is one type of airflow, vertical airflow (directed by horizontal vane).
2. Control of airflow direction can be automatic (angles of direction is determined by operation mode, heat exchanger temperature and intake air temperature) and manual (angles of direction can be adjusted using remote control).

#### Vertical Airflow

Operation Mode	Airflow Direction		Vane Angle (°)				
			1	2	3	4	5
Heating	Auto with Heat Exchanger Temperature	A Upward fix	161				
		B Downward fix	161				
		C Downward fix	197				
	D Downward fix	197					
	Manual		197	—	—	—	161
Cooling, Soft Dry and Ion	Auto		26 ~ 49				
	Manual		49	—	—	—	26

1. Automatic vertical airflow direction can be set using remote control; the vane swings up and down within the angles as stated above. For heating mode operation, the angle of the vane depends on the indoor heat exchanger temperature as Figure 1 below. When the air conditioner is stopped using remote control, the vane will shift to close position.
2. Manual vertical airflow direction can be set using remote control; the angles of the vane are as stated above and the positions of the vane are as Figure 2 below. When the air conditioner is stopped using remote control, the vane will shift to close position.

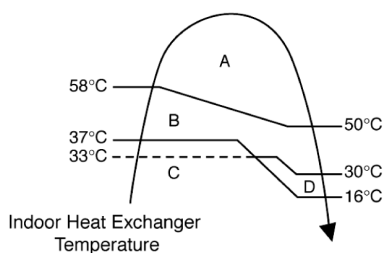

Figure 1

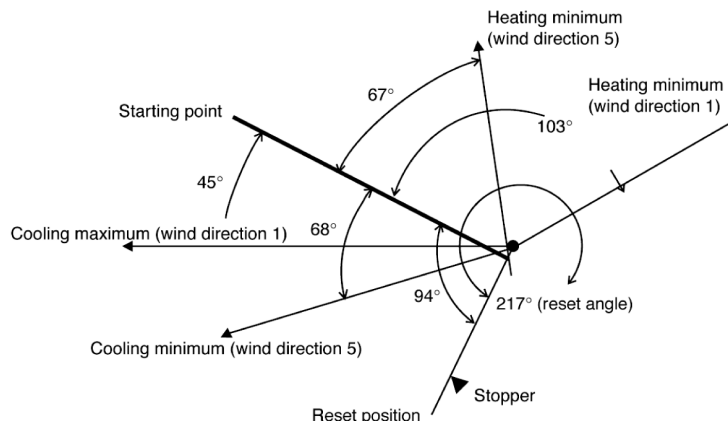

Figure 2

### 8.3.1.9. Quiet operation (Cooling Mode/Cooling area of Soft Dry Mode)

#### A. Purpose

To provide quiet cooling operation compare to normal operation.

#### B. Control condition

a. Quiet operation start condition

- When “quiet” button at remote control is pressed.  
Quiet LED illuminates.

b. Quiet operation stop condition

1. When one of the following conditions is satisfied, quiet operation stops:
  - a. Powerful button is pressed.
  - b. Stop by OFF/ON switch.
  - c. Timer “off” activates.
  - d. Quiet button pressed again.
2. When quiet operation is stopped, operation is shifted to normal operation with previous setting.
3. When fan speed is changed, quiet operation is shifted to quiet operation of the new fan speed.
4. When operation mode is changed, quiet operation is shifted to quiet operation of the new mode.
5. During quiet operation, if timer “on” activates, quiet operation maintains.
6. After off, when on back, quiet operation is not memorised.

#### C. Control contents

1. Fan speed is changed from normal setting to quiet setting of respective fan speed.  
This is to reduce sound of Hi, Me, Lo for 3dB.
2. Fan speed for quiet operation is -1 step from setting fan speed.

### 8.3.1.10. Quiet operation (Heating)

#### A. Purpose

To provide quiet heating operation compare to normal operation.

#### B. Control condition

a. Quiet operation start condition

- When “quiet” button at remote control is pressed.  
Quiet LED illuminates.

b. Quiet operation stop condition

1. When one of the following conditions is satisfied, quiet operation stops:
  - a. Powerful button is pressed.
  - b. Stop by OFF/ON switch.
  - c. Timer “off” activates.
  - d. Quiet button is pressed again.
2. When quiet operation is stopped, operation is shifted to normal operation with previous setting.
3. When fan speed is changed, quiet operation is shifted to quiet operation of the new fan speed.
4. When operation mode is changed, quiet operation is shifted to quiet operation of the new mode, except fan only mode.
5. During quiet operation, if timer “on” activates, quiet operation maintains.
6. After off, when on back, quiet operation is not memorised.

### C. Control contents

#### a. Fan Speed manual

1. Fan speed is changed from normal setting to quiet setting of respective fan speed.

This is to reduce sound of Hi, Me, Lo for 3dB.

2. Fan speed for quiet operation is -1 step from setting fan speed.

3. Fan Speed Auto

Indoor FM RPM depends on pipe temp sensor of indoor heat exchanger.

### 8.3.1.11. Powerful Mode Operation

When the powerful mode is selected, the internal setting temperature will shift to achieve the setting temperature quickly.

#### (a) Cooling Operation

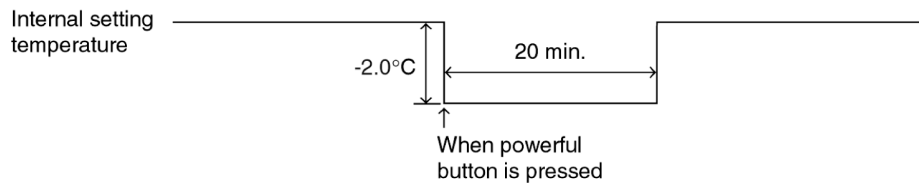

#### (b) Soft Dry Operation

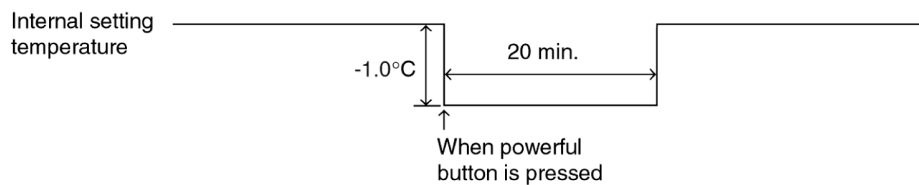

#### (c) Heating Operation

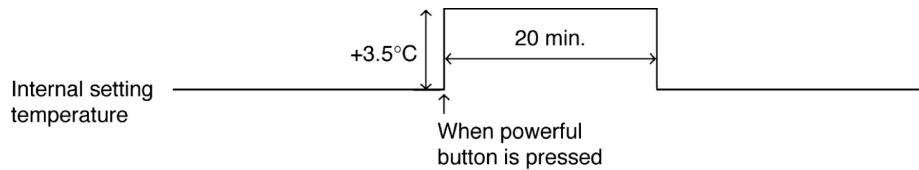

### 8.3.1.12. ON Timer Control

ON timer can be set using remote control, the unit with timer set will start operate earlier than the setting time. This is to provide a comfortable environment when reaching the set ON time.

60 minutes before the set time, indoor (at fan speed of Lo-) and outdoor fan motor start operate for 30 seconds to determine the indoor intake air temperature and outdoor air temperature in order to judge the operation starting time.

From the above judgment, the decided operation will start operate earlier than the set time as shown below.

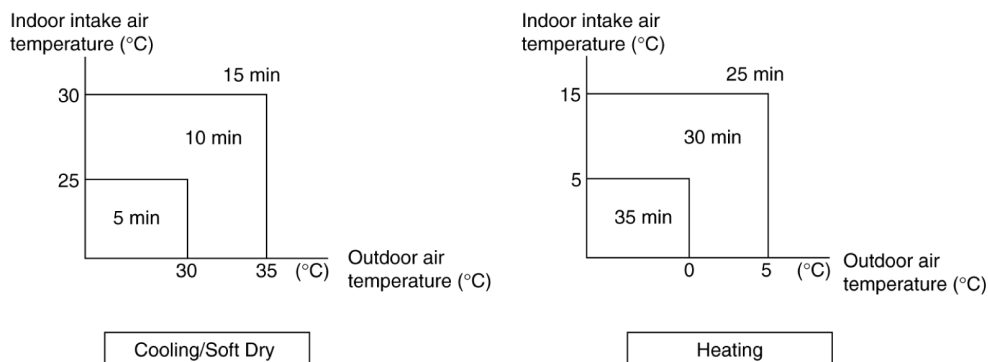

### 8.3.1.13. OFF Timer Control

OFF timer can be set using remote control, the unit with timer set will stop operate at set time.

### 8.3.1.14. Auto Restart Control

1. When the power supply is cut off during the operation of air conditioner, the compressor will re-operate within three to four minutes (there are 10 patterns between 2 minutes 58 seconds and 3 minutes 52 seconds to be selected randomly) after power supply resumes.

2. This type of control is not applicable during ON/OFF Timer setting.

### 8.3.1.15. Indication Panel

LED	POWER	TIMER	QUIET	POWERFUL	AIR SWING
Color	Green	Orange	Orange	Orange	Orange
Light ON	Operation ON	Timer Setting ON	Quiet Mode ON	Powerful Mode ON	Auto Air Swing ON
Light OFF	Operation OFF	Timer Setting OFF	Quiet Mode OFF	Powerful Mode OFF	Auto Air Swing OFF

#### Note:

- If POWER LED is blinking, the possible operations of the unit are Hot Start, during Deice operation, operation mode judgment, or delay ON timer sampling.
- If timer LED is blinking, there is an abnormality operation occurs.

### 8.3.1.16. Auto Operation Switch

Number of "beep":	1	2	3	4
Function:	Auto Operation	Forced Cool	Forced Heat	Various Setting Mode
Duration (s):	0	5	8	11
				16
				21

1. When the switch is pressed between 0 to 5 seconds, Auto Mode operation starts to function.
2. When the switch is pressed between 5 to 8 seconds, the unit is forced to operate in Cooling Mode.
3. When the switch is pressed between 8 to 11 seconds, the unit will enter forced Heating Mode standby. Press timer decrement button for 5s for the unit to operate in Heating Mode.
4. When the switch is pressed between 11 to 16 seconds and together with the signal from remote control (timer decrement button for 5s), the unit can be changed to different controlling setting (4 type of transmission codes).
5. When the switch is pressed between 16 to 21 seconds, either "H14" error detection selection mode or the remote control signal receiving sound can be cancelled or turned on.

### 8.3.1.17. Freeze Prevention Control

1. When indoor heat exchanger temperature is lower than 2°C continuously for six minutes, compressor will stop operating.
2. Compressor will resume its operation three minutes after the indoor heat exchanger is higher than 10°C.
3. At the same time, indoor fan speed increase +20 rpm compared to its normal operation.
4. If indoor heat exchanger temperature is higher than 10°C for five minutes, the fan speed will return to its normal operation.

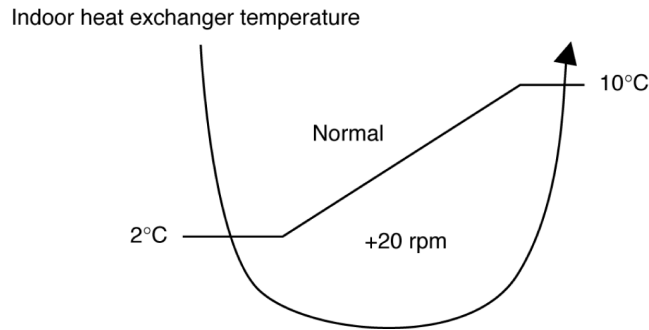

### 8.3.1.18. Dew Prevention Control

a. Purpose

To prevent dew.

b. Control start conditions

When indoor units are ceiling floor, duct and mini-cassette.

c. Control contents

Hz control is carried out according to the dew prevention status transmitted from indoor.

Dew prevention status (transmitted indoor)	Control contents	
	Relative control domain	MAX domain
0 (it usually controls)	Usually, control	Usually, control
1 (rise)	Relative change control priority	On tap up/10 seconds
2 (changeless)	Changeless	Changeless
3 (down)	-2 Hz/10 seconds	-2 Hz/10 seconds

Change is once to 10 seconds.

\* Once the stand-up went into the down domain by Fcmax as for the Fcmax domain, it shifts to relative changes control domain.

When the higher rank of relative control has this control and the status signal of 2-3 has come out.

Relative change control is stopped and follows directions of spray control.

Priority is given to the which is larger when freeze prevention down status and dew prevention down status are transmitted simultaneously.

In the case of dew prevention status  $\neq 0$ , it is referred to as maxFc.

## 8.4. Mini-Cassette Type

### 8.4.1. Basic Function

Inverter control, which equipped with a microcomputer in determining the most suitable operating mode as time passes, automatically adjusts output power for maximum comfort always. In order to achieve the suitable operating mode, the microcomputer maintains the set temperature by measuring the temperature of the environment and performing temperature shifting. The compressor at outdoor unit is operating following the frequency instructed by the microcomputer at indoor unit that judging the condition according to internal setting temperature and intake air temperature.

#### 8.4.1.1. Internal Setting Temperature

Once the operation starts, remote control setting temperature will be taken as base value for temperature shifting processes. These shifting processes are depending on the air conditioner settings and the operation environment. The final shifted value will be used as internal setting temperature and it is updated continuously whenever the electrical power is supplied to the unit.

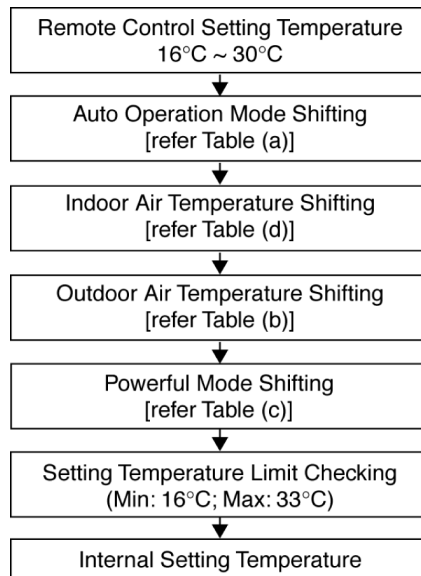

**Table (a): Auto Operation Mode Setting**

Mode Shift:	Temperature Shift (°C)
Cooling/Soft Dry → Heating	-2.0
Heating → Cooling/Soft Dry	+2.0

**Table (b): Outdoor Air Temperature Shifting**

Mode:	Outdoor Temperature, X (°C):	Temperature Shift (°C)
Cooling/Soft Dry	$30 \leq X$	+0.5
	$X < 30$	+1.0
Heating	$9 \leq X$	-1.0
	$5 \leq X < 9$	-0.5
	$1 \leq X < 5$	0.0
	$X \leq 1$	+1.0

**Table (c): Power Mode Shifting**

Mode:	Temperature Shift (°C)
Cooling	-4.0
Soft Dry	-2.0
Heating	+6.0

**Table (d): Indoor Air Temperature Shifting**

1. Target room temperature shift value (dGetaDst)

- To offset the absolute gap between detection temperature with actual room temperature.
- The heat exchanger unit's temperature is different based on operation mode, it becomes the action operation mode value.

Actual operation mode	Target room temperature offset value (dGetaDst)
Cooling	(1)
Heating	(2)
Soft Dry	(0)

2. Room temperature shift value (dGeta)

- When compressor ON/OFF, correction of detected room temperature by shift value during defrost etc.
  - i) Initial value when operation starts, or changing the actual operation mode.

Set the offset value at each operation mode. However, in order to improve the heating startup efficiency, the offset value will be changed based on the gap between setting temperature and room temperature.

Actual operation mode	Gap between setting temperature and room temperature	Room temperature offset value (dGeta)
Cool	—	(0)
Heat	(Operation start set temp. - room temp.) < 4°C	(4)
	(Operation start set temp.) ≥ 4°C	(4)
Soft Dry	—	(0)

ii) Updating during operation

During operation, it will compare with the target room temperature offset value at specific period, then the room temperature will be updated.

Actual operation mode	Room temperature zone	Updating period (sec.)
Cool	—	(180)
Heat	A, B, C, D zone	(15)
Soft Dry	—	(180)

Update the room temperature offset value (dGeta)

Temperature condition	Room temp. offset value after modified (dGeta)
Target room temp. offset value > Room temp. offset value (dGetaDst > dGeta)	dGeta + (0.5)
Target room temp. offset value < Room temp. offset value (dGetaDst < dGeta)	dGeta - (0.5)
Target room temp. offset value = Room temp. offset value (dGetaDst = dGeta)	Do not change.

However, if the following condition is occurred, temperature cannot detect correctly and therefore no updating will be done.

- Heating zone E and above (Temperature gap is big and great capacity increased.)
- During deice
- After deice complete \*within 600 sec.
- Comp. stop
- Comp. starting \*within 600 sec.

### 8.4.1.2. Simultaneous Operation Control

**1. Operation modes which can be selected using the remote control unit:**

Automatic, Cooling, Soft Dry, Heating, Fan operation mode.

**2. Types of operations mode which can be performed simultaneously**

- Cooling operation and cooling, Soft Dry or fan operation
- Heating operation and heating operation

**3. Types of operation modes which cannot be performed simultaneously**

- While a cooling operation is in progress, a heating operation cannot be performed by an indoor unit in another room.

In the room where the operation is in progress, a cooling was pressed first, operation is continued. In the room where the operation button for heating was pressed afterward, the operation lamp of the indoor unit blinks, where the attempt is made to establish the heating operation. Its fan is stopped, and the air does not discharged.

- While a cooling operation is in progress, a heating operation cannot be performed by an indoor unit in another room.

In the room where the operation is in progress, a cooling was pressed first, operation is continued. In the room where the operation button for cooling was pressed afterward, the operation lamp of the indoor unit blinks, where the attempt is made to establish the cooling operation. Its fan is stopped, and the air does not discharged.

**4. Operation mode priority control**

- The operation mode designated first by the indoor unit has priority.
- If the priority indoor unit stops operation or initiates the fan operation, the priority is transferred to other indoor units.

“Waiting” denotes the standby status in which the operation lamp LED blinks (ON for 2.5 sec. and OFF for 0.5 sec.), and the fan is stopped.

A ROOM \ B ROOM		Non Priority Unit (2nd. ON)			
		Cooling	Soft Dry	Heating	Fan
Priority Unit (1st. ON)	Cooling	C / C	C / D	C / Waiting	C / F
	Soft Dry	D / C	D / D	D / Waiting	D / F
	Heating	H / Waiting	H / Waiting	H / H	H / Stop
	Fan *	F / C	F / D	Stop / H	F / F

\* In the fan mode, priority is transferred to a non-priority unit.

**Note**

- C: Cooling operation mode
- D: Soft Dry operation mode
- H: Heating operation mode
- F: Fan operation mode

### 8.4.1.3. Cooling Operation

#### 8.4.1.3.1. Thermostat control

- Compressor is OFF when Intake Air Temperature - Internal Setting Temperature  $< -1.5^{\circ}\text{C}$ .
- Compressor is ON after waiting for 3 minutes, if the Intake Air Temperature - Internal Setting Temperature  $>$  Compressor OFF point.

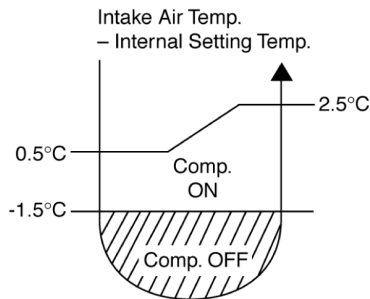

### 8.4.1.4. Soft Dry Operation

#### 8.4.1.4.1. Thermostat control

- Compressor is OFF when Intake Air Temperature - Internal Setting Temperature  $< -2.0^{\circ}\text{C}$ .
- Compressor is ON after waiting for 3 minutes, if the Intake Air Temperature - Internal Setting Temperature  $>$  Compressor OFF point.

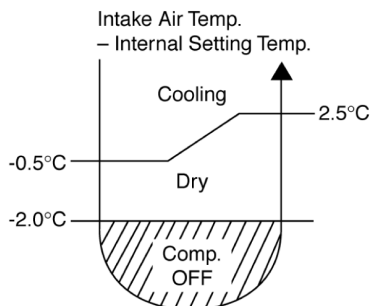

### 8.4.1.5. Heating Operation

#### 8.4.1.5.1. Thermostat control

- Compressor is OFF when Intake Air Temperature - Internal Setting Temperature  $< +2.0^{\circ}\text{C}$ .
- Compressor is ON after waiting for 3 minutes, if the Intake Air Temperature - Internal Setting Temperature  $>$  Compressor OFF point.

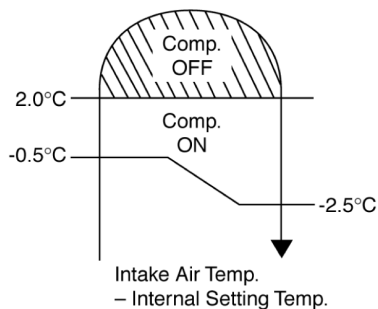

### 8.4.1.6. Automatic Operation

This mode can be set using remote control and the operation is decided by remote control setting temperature, indoor intake air temperature and outdoor air temperature.

During operation mode judgment, indoor fan motor (with speed of Lo-) and outdoor fan motor are running for 30 seconds to detect the indoor intake and outdoor air temperature. The operation mode is decided based on below chart.

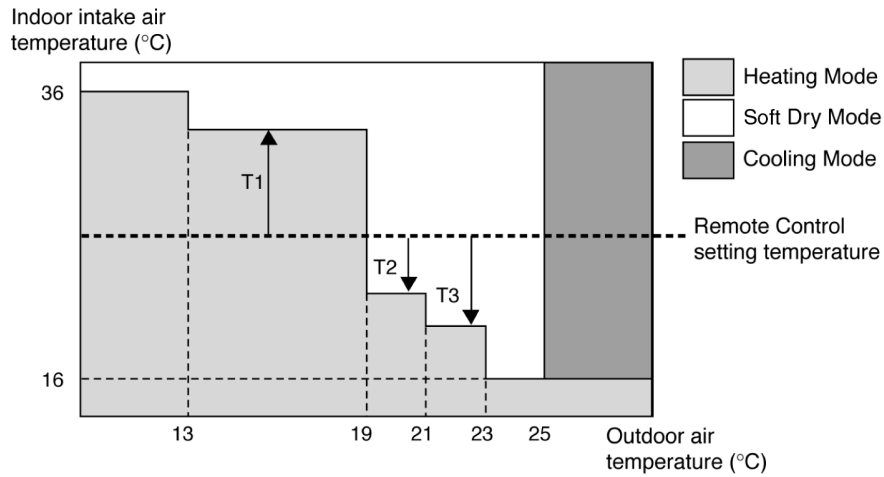

Values of T1, T2, and T3 depend on remote control setting temperature, as shown in below table. After the adjustment of T1, T2 and T3 values, the operation mode for that particular environment and remote control setting is judged and performed, based on the above operation mode chart, every 30 minutes.

Remote Control Setting Temperature (°C)	T1	T2	T3
16 ~ 18	+10	-3	-5
19 ~ 22	+8	-3	-7
23 ~ 26	+7	-3	-7
27 ~ 30	+6	-3	-8

There is a temperature shifting on T1, T2, and T3 if the operation mode judged is changed from Cooling/Soft Dry to Heating or vice versa.

Operation Mode change from	Temperature shifts (°C)
Cooling/Soft Dry → Heating	-2
Heating → Cooling/ Dry	+2

Example of operation mode chart adjustment:

From the above table, if remote control setting temperature = 25,

$T1 = 25 + 7 = 32$ ;  $T2 = 25 - 3 = 22$ ;  $T3 = 25 - 7 = 18$

The operation mode chart for this example is as shown in below figure and the operation mode to be performed will depend on indoor intake air temperature and outdoor air temperature at the time when the judgment is made.

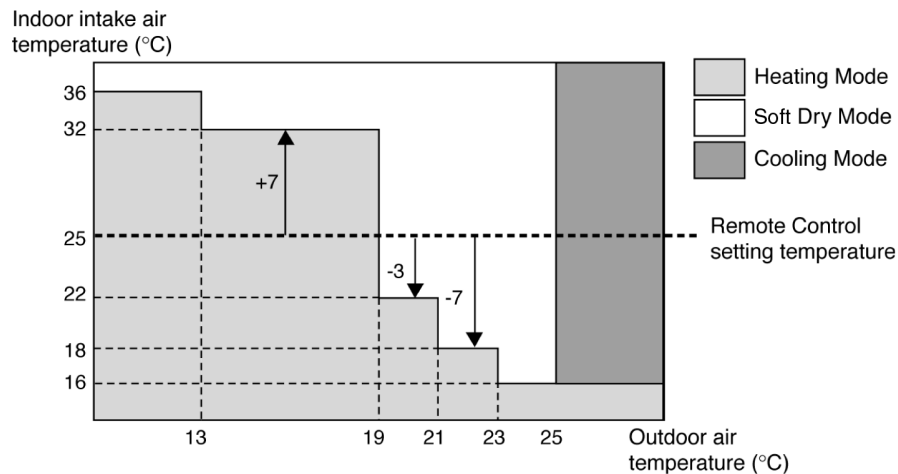

### 8.4.1.7. Indoor Fan Motor Operation

#### A. Basic Rotation Speed (rpm)

- Required rotation speed for fan is set to respond to the remote control setting (10 rpm unit)

#### [Cooling, Soft Dry, Fan]

Remote Control	—	—	O	O	O	O	O	—	—	—
Tab (rpm)	PSHi	SHi	Hi	Me+	Me	Me-	Lo	Lo-	SLo	SSLo
CS-E15DB4EW	600	600	560	520	480	440	400	350	310	200
CS-E18DB4EW	640	640	590	550	510	470	430	390	350	200

#### [Heating]

Remote Control	—	—	O	O	O	O	O	—	—	—
Tab (rpm)	PSHi	SHi	Hi	Me+	Me	Me-	Lo	Lo-	SLo	SSLo
CS-E15DB4EW	650	650	600	570	540	510	480	460	300	300
CS-E18DB4EW	690	690	640	600	570	530	490	470	320	300

## B. Indoor Fan Control

### i. Indoor fan control operation outline

#### 1. Cooling / Soft Dry

		Cooling	Soft Dry	Ionizer			
Under different mode standby		Stop					
Forced Operation		Hi	—	—			
SEER Measurement mode	The minimum capability	Lo	—	—			
	Middle capability	Hi	—	—			
	Standard rating capacity (rated capability)	Hi	—	—			
Other than above	Min. control	Automatic operation mode judgement					
	Other than above	Freeze proofing		Designated air flow shift	Designated air flow shift	—	
		With dew		Designated air flow shift	Designated air flow shift	—	
	Other than above	Operation	—		—	—	
			Automatic operation		Lo	SLo	Usually, automatic
			Manual Operation	Powerful	Setting +2UP		—
		Quiet		Setting -1down	—		
		Other than the above	Automatic Operation	Powerful	Powerful automatic	SLo	—
				Quiet	Quiet automatic		—
			Other than the above	Usually, automatic	SLo	Usually, automatic	
		Other than the above	Manual Operation	Powerful	Setting +2UP	SLo	—
				Quiet	Setting -1down	SLo	—
				Other than the above	Remote control setup	SLo	Remote control setup
	MAX capability		SHi	—	—		

2. Heating

		Heating			
Waiting for other mode		Stop			
Forced Operation		SHi			
SEER Measurement mode		The minimum capability	Lo		
		Middle capability	SHi		
		Rated capability	SHi		
Min. control	Automatic operation mode judging		Lo-		
Other than above	During hot start		Stop		
	Under defrosting operation		Stop		
	Ability supply stop		Stop		
	Low-temperature capability measurement		SSH i		
	MAX control	Heating starting force operation		A stop, SLo	
		Ability supply stop		Lo-	
		Thermostat-off sampling		Specification	
		Piping temperature control		min Restrictions of fan speed by indoor pipe temperature	
	Min control	Fan speed minimum restrictions by indoor piping temperature		Me	
		Fan speed automatic minimum		Auto Fan Speed min Control	
	Other than above	Preparation operation start timer.	Fan speed automatic		Lo
			Manual Operation	Powerful	Setting +2UP
				Quiet	Setting -1down
		Other than the above		Remote control setup	
		Other than above	Fan speed shift control		Heating Fan Speed Control
Fan speed automatic			Powerful	Pipe temperature control +2UP	
			Quiet	Pipe temperature control -1down	
			Other than the above	Piping temperature control	
Fan speed manual			Powerful	Setting +2UP	
			Quiet	Setting -1down	
			Other than the above	Remote control setup	

ii. Auto Fan Speed

1. Cooling

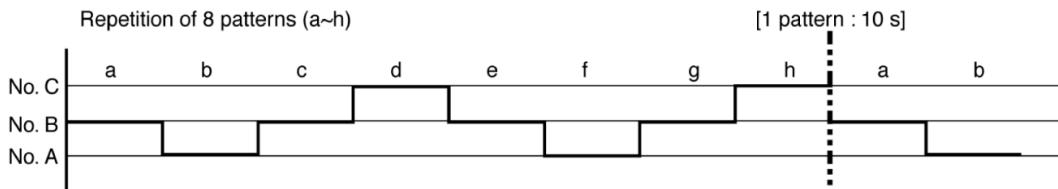

	Model	No. A	No. B	No. C
Powerful Program	CS-E15DB4EW	540	560	580
	CS-E18DB4EW	605	625	645
Normal Program	CS-E15DB4EW	480	500	520
	CS-E18DB4EW	545	565	585
Quiet Program	CS-E15DB4EW	460	480	500
	CS-E18DB4EW	525	545	565

## 2. Heating

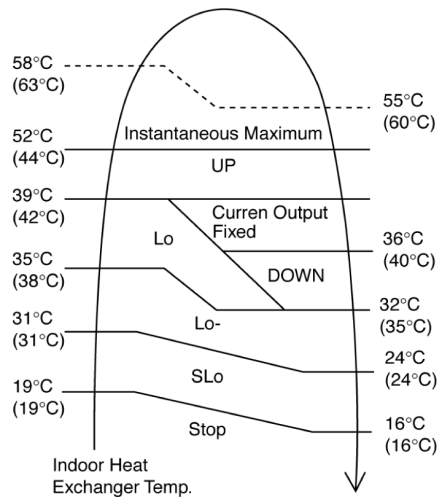

Note:

a. UP:

- If move from Lo, the fan speed will be shifted to Maximum 1,520 rpm.
- If move from Maximum, the fan speed no change.
- In up zone, 10 rpm is added for every 10s until Maximum 1,520 rpm.

b. DOWN:

- The fan speed will be decreased one step every 10 sec. until Minimum 1,270 rpm.

c. Current Output Fixed:

- Maintain at present fan speed.

d. Instantaneous Maximum:

- Fan speed will be increased to maximum auto fan speed.

e. Temperature in ( ) is for Powerful Mode operation.

## C. Fan Motor Control

1. Motor specification

High voltage PWM Motor

2. Feedback Control

a. Number-of -rotations feedback

Immediately after the fan started, rpm is checked and duty is added, and feedback control is performed. For high voltage PWM motor. It is done once every 0.5 seconds.

b. Offset duty T max/min limit

High voltage PWM motor has maximum offset duty.

(Refer to indoor fan motor control basic rotation speed.)

3. Abnormal detection Control

Conditions:

a. Out of rhythm signal input

b. If feedback number of rotations exceeded #2550 r/min or when less than #50 r/min.

Control: Fans stop.

Return: Restart after 5 seconds.

\* It will not detect out of rhythm condition within 5s for phase control motor (PWM motor is when duty = 0) after start.

A fan stops when condition (1) and (2) happen within 25.0 seconds after fan starting, and if this happens for continuously 7 times, it will not retry.

→ FM lock processing

4. Restart Prohibition Control

Restart is prohibited within 5s for phase control motor (PWM motor is when duty = 0) after dan stop (except re-ON the power supply)

## D. Deodorizing Control

### i. Control condition

Control at cooling/soft dry operation and auto fan speed setting.

No Deodorizing Control is performed during ON timer standby operation and during freeze prevention control.

### ii. Operation

The odor status is arranged as below and it is shifted as follows.

- \* When COMP is ON 1 → 2 → 3  
(Shift to 4 when COMP is OFF)
- \* When COMP is OFF 4 → 5 → 6 → 7 → 6 ←→ 7  
(Shift to 1 when COMP is ON)
- \* Start from 4 if the Thermostat is OFF during the start operation.

Odor Status		1	2	3	4	5	6	7	6.7.6...	1
Status Shift according to COMP		ON			OFF					ON
Status Shift according to time (s)	Cooling zone	40	50	—	30	90	20	90	20.90.20...	ON
	Dry zone									
Fan Speed	Cooling zone	OFF	SSLo	Auto Fan Speed	SSLo	OFF	SSLo	OFF	SSLo.OFF...	
	Dry zone			SLo						

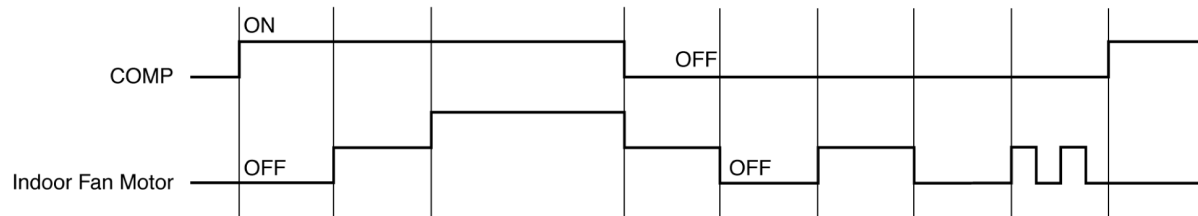

※ During FM OFF state, auto judgement will cause the FM to ON.

## 8.4.1.8. Airflow Direction

1. There is one type of airflow, vertical airflow (directed by horizontal vane).
2. Control of airflow direction can be automatic (angles of direction is determined by operation mode, heat exchanger temperature and intake air temperature) and manual (angles of direction can be adjusted using remote control).

### Vertical Airflow

Operation Mode	Airflow Direction		Vane Angle (°)				
			1	2	3	4	5
Heating	Auto with Heat Exchanger Temperature	A Upward fix	70				
		B Downward fix	70				
	C Downward fix	20					
	D Downward fix	20					
	Manual		20	—	—	—	70
Cooling, Soft Dry and Ion	Auto		20 ~ 70				
	Manual		20	—	—	—	70

1. Automatic vertical airflow direction can be set using remote control; the vane swings up and down within the angles as stated above. For heating mode operation, the angle of the vane depends on the indoor heat exchanger temperature as Figure 1 below. When the air conditioner is stopped using remote control, the vane will shift to close position.

2. Manual vertical airflow direction can be set using remote control; the angles of the vane are as stated above and the positions of the vane are as Figure 2 below. When the air conditioner is stopped using remote control, the vane will shift to close position.

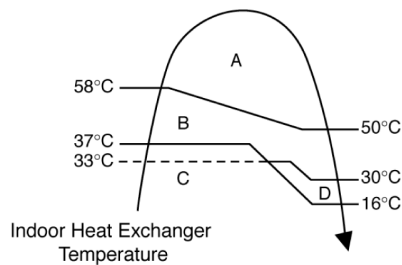

Figure 1

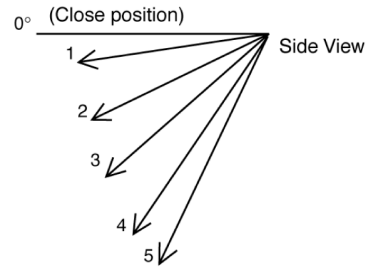

Figure 2

### 8.4.1.9. Quiet operation (Cooling Mode/Cooling area of Soft Dry Mode)

#### A. Purpose

To provide quiet cooling operation compare to normal operation.

#### B. Control condition

##### a. Quiet operation start condition

- When “quiet” button at remote control is pressed.  
Quiet LED illuminates.

##### b. Quiet operation stop condition

1. When one of the following conditions is satisfied, quiet operation stops:
  - a. Powerful button is pressed.
  - b. Stop by OFF/ON switch.
  - c. Timer “off” activates.
  - d. Quiet button is pressed again.
2. When quiet operation is stopped, operation is shifted to normal operation with previous setting.
3. When fan speed is changed, quiet operation is shifted to quiet operation of the new fan speed.
4. When operation mode is changed, quiet operation is shifted to quiet operation of the new mode.
5. During quiet operation, if timer “on” activates, quiet operation maintains.
6. After off, when on back, quiet operation is not memorised.

#### C. Control contents

1. Fan speed is changed from normal setting to quiet setting of respective fan speed.  
This is to reduce sound of Hi, Me, Lo for 3dB.
2. Fan speed for quiet operation is -1 step from setting fan speed.

### 8.4.1.10. Quiet operation (Heating)

#### A. Purpose

To provide quiet heating operation compare to normal operation.

#### B. Control condition

##### a. Quiet operation start condition

- When “quiet” button at remote control is pressed.  
Quiet LED illuminates.

b. Quiet operation stop condition

1. When one of the following conditions is satisfied, quiet operation stops:
  - a. Powerful button is pressed.
  - b. Stop by OFF/ON switch.
  - c. Timer "off" activates.
  - d. Quiet button is pressed again.
2. When quiet operation is stopped, operation is shifted to normal operation with previous setting.
3. When fan speed is changed, quiet operation is shifted to quiet operation of the new fan speed.
4. When operation mode is changed, quiet operation is shifted to quiet operation of the new mode, except fan only mode.
5. During quiet operation, if timer "on" activates, quiet operation maintains.
6. After off, when on back, quiet operation is not memorised.

**C. Control contents**

- a. Fan Speed manual
  1. Fan speed is changed from normal setting to quiet setting of respective fan speed.  
This is to reduce sound of Hi, Me, Lo for 3dB.
  2. Fan speed for quiet operation is -1 step from setting fan speed.
3. Fan Speed Auto  
Indoor FM RPM depends on pipe temp sensor of indoor heat exchanger.

**8.4.1.11. Powerful Mode Operation**

When the powerful mode is selected, the internal setting temperature will shift to achieve the setting temperature quickly.

(a) Cooling Operation

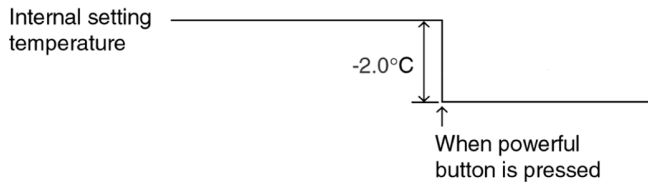

(b) Soft Dry Operation

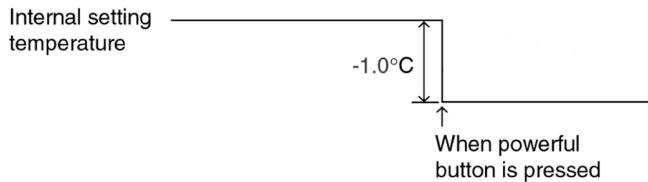

(c) Heating Operation

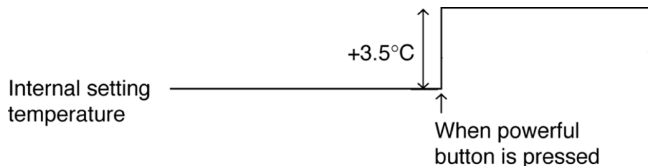

### 8.4.1.12. ON Timer Control

ON timer can be set using remote control, the unit with timer set will start operate earlier than the setting time. This is to provide a comfortable environment when reaching the set ON time.

60 minutes before the set time, indoor (at fan speed of Lo-) and outdoor fan motor start operate for 30 seconds to determine the indoor intake air temperature and outdoor air temperature in order to judge the operation starting time.

From the above judgment, the decided operation will start operate earlier than the set time as shown below.

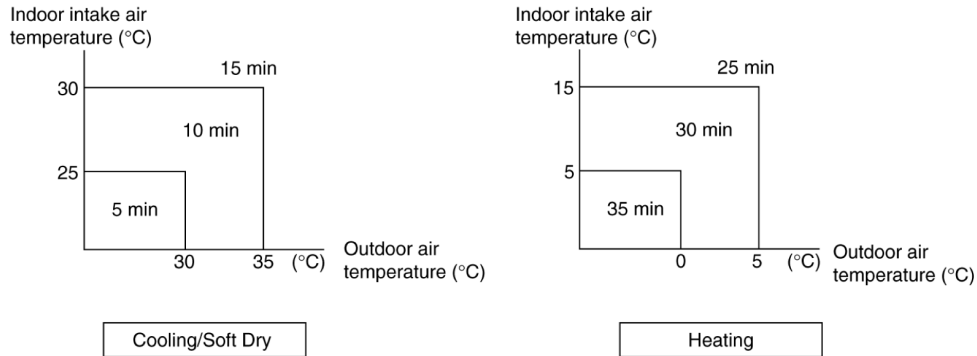

### 8.4.1.13. OFF Timer Control

OFF timer can be set using remote control, the unit with timer set will stop operate at set time.

### 8.4.1.14. Auto Restart Control

- When the power supply is cut off during the operation of air conditioner, the compressor will re-operate within three to four minutes (there are 10 patterns between 2 minutes 58 seconds and 3 minutes 52 seconds to be selected randomly) after power supply resumes.
- This type of control is not applicable during ON/OFF Timer setting.

### 8.4.1.15. Indication Panel

LED	POWER	TIMER	QUIET	POWERFUL	AIR SWING
Color	Green	Orange	Orange	Orange	Orange
Light ON	Operation ON	Timer Setting ON	Quiet Mode ON	Powerful Mode ON	Auto Air Swing ON
Light OFF	Operation OFF	Timer Setting OFF	Quiet Mode OFF	Powerful Mode OFF	Auto Air Swing OFF

**Note:**

- If POWER LED is blinking, the possible operations of the unit are Hot Start, during Deice operation, operation mode judgment, or delay ON timer sampling.
- If timer LED is blinking, there is an abnormality operation occurs.

### 8.4.1.16. Auto Operation Switch

Number of "beep":	1	2	3	4		
Function:	Auto Operation	Forced Cool	Forced Heat	Various Setting Mode	Individual Counter-action	
Duration (s):	0	5	8	11	16	21

- When the switch is pressed between 0 to 5 seconds, Auto Mode operation starts to function.
- When the switch is pressed between 5 to 8 seconds, the unit is forced to operate in Cooling Mode.
- When the switch is pressed between 8 to 11 seconds, the unit will enter forced Heating Mode standby. Press timer decrement button for 5s for the unit to operate in Heating Mode.

4. When the switch is pressed between 11 to 16 seconds and together with the signal from remote control (timer decrement button for 5s), the unit can be changed to different controlling setting (4 type of transmission codes).
5. When the switch is pressed between 16 to 21 seconds, either "H14" error detection selection mode or the remote control signal receiving sound can be cancelled or turned on.

#### 8.4.1.17. Freeze Prevention Control

1. When indoor heat exchanger temperature is lower than 2°C continuously for six minutes, compressor will stop operating.
2. Compressor will resume its operation three minutes after the indoor heat exchanger is higher than 10°C.
3. At the same time, indoor fan speed increase +20 rpm compared to its normal operation.
4. If indoor heat exchanger temperature is higher than 10°C for five minutes, the fan speed will return to its normal operation.

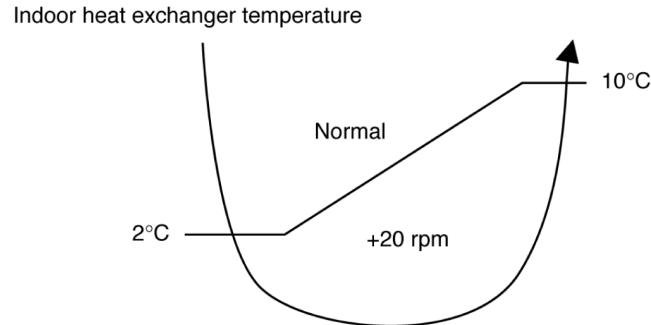

#### 8.4.1.18. Dew Prevention Control

a. Purpose

To prevent dew.

b. Control start conditions

When indoor units are ceiling floor, duct and mini-cassette.

c. Control contents

Hz control is carried out according to the dew prevention status transmitted from indoor.

Dew prevention status (transmitted indoor)	Control contents	
	Relative control domain	MAX domain
0 (it usually controls)	Usually, control	Usually, control
1 (rise)	Relative change control priority	On tap up/10 seconds
2 (changeless)	Changeless	Changeless
3 (down)	-2 Hz/10 seconds	-2 Hz/10 seconds

Change is once to 10 seconds.

\* Once the stand-up went into the down domain by Fcmax as for the Fcmax domain, it shifts to relative changes control domain.

When the higher rank of relative control has this control and the status signal of 2-3 has come out.

Relative change control is stopped and follows directions of spray control.

Priority is given to the which is larger when freeze prevention down status and dew prevention down status are transmitted simultaneously.

In the case of dew prevention status  $\neq 0$ , it is referred to as maxFc.

## 8.5. Outdoor Unit Operation

### 8.5.1. Room Temperature Control

#### 8.5.1.1. Cooling, Soft Dry and Heating Operations

1. Immediately after the compressor has started up during an ongoing operation, the initial frequency is determined on the basis of the information obtained from the heat exchanger capacities of the indoor units (thermostat ON) and the airflows set by their remote controls.
2. During an ongoing operation, the difference between the temperature set in each of the rooms and the room temperature is detected, the total load is calculated, and the compressor frequency is determined on the basis of this information.
3. When one room turns the thermostat OFF while two or more indoor units are operating, the automatic expansion valve closes to restrict the flow of refrigerant, the compressor control is temporarily suspended, and both the initial frequency and total load are determined again.
4. When the thermostat is turned OFF during 1-room operation, the outdoor unit's compressor and fan stop. (The outdoor unit's fan stops 60 seconds after the compressor.)
5. It takes about 180 seconds for the compressor to be restarted after it has stopped. (Re-start control)

#### 8.5.1.2. Deice Operation Control <Heating>

##### Outline

##### Heat Pump Only

Defrosting is carried out by the cooling cycle (reverse cycle). The defrosting time or outdoor heat exchanger temperature must be more than its fixed value when finishing.

##### Detail

##### Conditions for Starting Defrost

The starting conditions must be made with the outdoor air temperature and heat exchanger temperature. Under the conditions that the system is in heating operation, 6 minutes after the compressor is started and more than 38 minutes of accumulated time pass since the start of the operation or ending the defrosting.

##### Conditions for Canceling Defrost

The target heat exchanger temperature as the canceling condition is selected in the range of  $4^{\circ}\text{C} < \text{Te} < 12^{\circ}\text{C}$  according to the air temperature as the following formula.

$$\text{The target heat exchanger temperature} = -(45/65)(\text{ambient temperature}) + 14$$

The defrost operation surely operates in 120 seconds after the start. (A→B)  
After then the defrost operation stops at the following conditions.

1. When the heat exchanger temperature reaches the target heat exchanger temperature. (B→C)
2. When 650 seconds have passed after the start even if the heat exchanger temperature does not reaches the target heat exchanger temperature. (C)

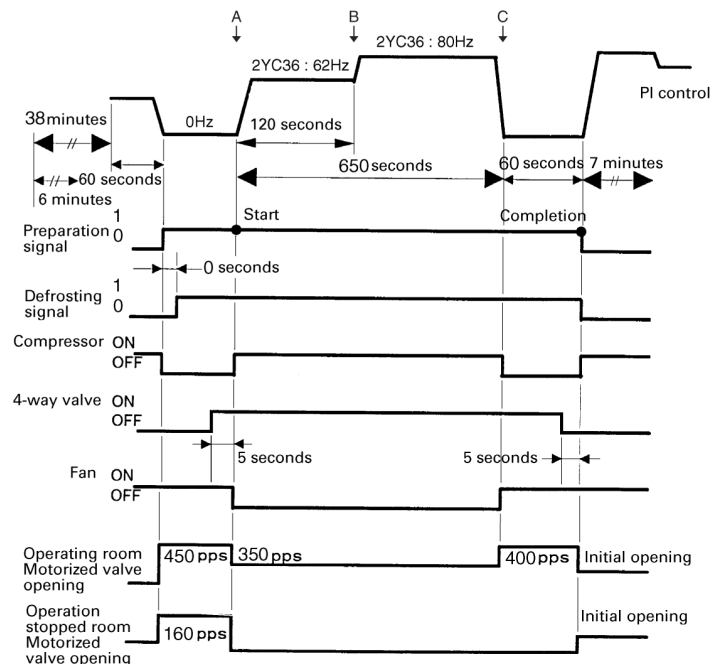

## 8.6. Forced Cooling Operation Control

- Forced cooling operations can be performed by the outdoor unit.
1. Set the operation mode setting switch (SW2) to COOL.
  2. The forced cooling operation is performed when the forced operation switch (SW1) is pressed.
- \* The forced cooling operation stops when the forced operation switch (SW1) is pressed again.

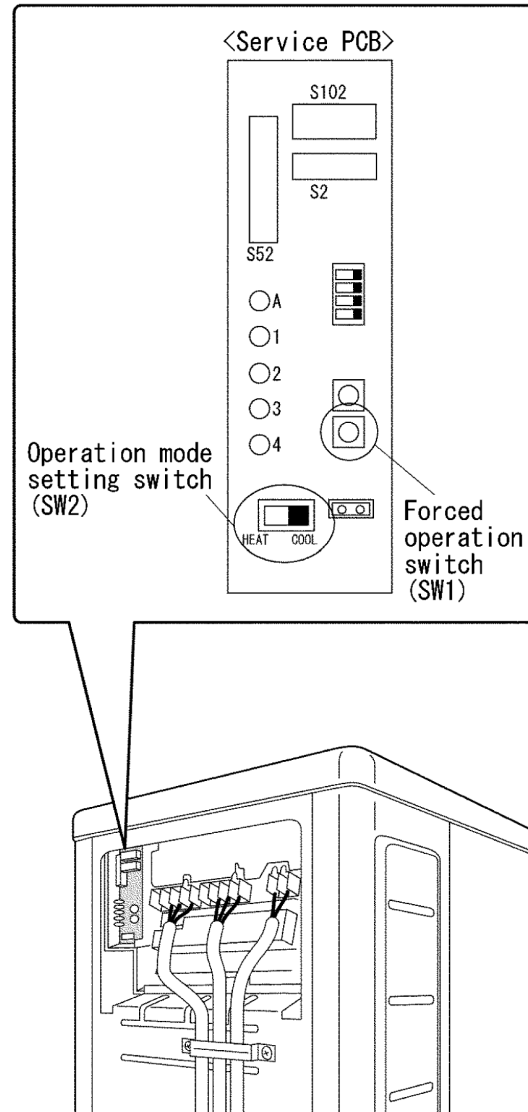

## 8.7. Wiring Error Check Control

The useful wiring error check function automatically corrects wiring errors using a microcomputer.

In cases where wires are embedded or the locations of connecting wires are not known for other reasons, for instance, pressing the wiring error check switch inside the right side panel of the outdoor unit enables operation as is even if the wires to room A are connected to room B by mistake. Wiring error checks cannot be performed in the following situations:

- For about 30 seconds (during the initial settings) after the power was turned on.
- During the 3-minute standby after the compressor has stopped.
- When the outside air temperature is below 5 °C.
- When trouble has occurred in the indoor unit (including trouble in transmission to all rooms).

**This function need not be used if the correct piping and wiring are completely done.**

### ■ Operation method

1. Remove the service panel (right side panel). (5 screws)
2. Press the writing error check switch on the service monitor P.C. Board to start the writing error check operation.
3. The writing error check is automatically completed in about 10 to 15 minutes.
4. When the faulty wiring check is completed, the service monitor LEDs blink.

LED	1	2	3	4	Judgement
Display	All LEDs blink			Blinking	Automatic Correction cannot be done.
	Blink in squence			Off	Automatic Correction have been implemented.

Automatic correction have been implemented: LEDs 1, 2 and 3 blink in sequence (LED4 is off).

Automatic correction cannot be done: LEDs 1 to 4 blink simultaneously to indicate:

- A transmission problem in one of the indoor units.
- A disconnected heat exchanger thermistor in an indoor unit
- Trouble in an indoor unit (when the trouble has occurred during the wiring error check)

Trouble stopping: One of the LEDs 1 to 4 lights.

### Precautions

1. About 10 to 15 minutes are required to conduct the check after the wiring error switch is pressed. (Only wiring error between an unit A and unit B cannot be corrected.)
2. If liquid pipes and gas pipe connected to different unit it cannot be corrected "automatically", be absolutely sure to run the liquid pipes and gas pipes in pairs.
3. If the wiring error check switch is pressed again during a wiring error check, the wiring error check can be forcibly terminated. In this case, what is stored in the microcomputer will be the initial statuses (wiring room A → piping A port, wiring room B → piping B port).
4. **The wiring error check function MUST be used when the outdoor unit P.C. Board is replaced.**

### Basic knowledge

- The principle operation of this function is as follows: The refrigerant flows in succession from the port A, and by detecting the temperature of the indoor unit heat exchanger sensor, the connected pipes and wires are collated.
- The sound of ice forming (a crackling noise) may be heard from the indoor unit while this function is operating: this is normal and not indicative of a malfunction. (This phenomenon occurs because the heat exchanger temperature is lowered to 0 °C or below in order to improve the detection accuracy.)
- The indoor fan is also set to ON and OFF at the same time.

### ■ How to check the information currently stored in the microcomputer

This information can be checked by observing the blinking of the LEDs on the service monitor upon completion of the wiring error check, during forced operation or after stopped.

LED1: Wiring room A, LED2: wiring room B

The first LED to blink denotes the piping port A and the second LED denotes the piping port B.

The LED which has lighted first denotes the room whose wiring is connected to the piping port A, and the next LED denotes the port B.

<Example> When the LEDs blink as shown below

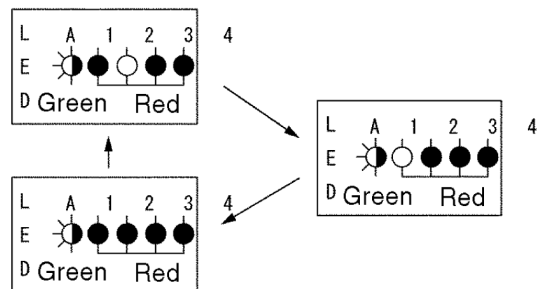

The LEDs in this figure denote that the piping port A has been connected (automatically corrected) to the wiring room B and that the piping port B has been connected (automatically corrected) to the wiring room A.

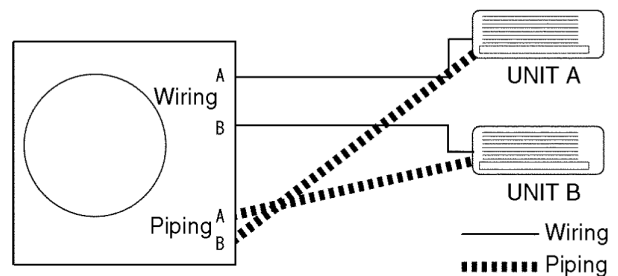

## 8.8. Outdoor Unit - Check Point

〈 LED on outdoor unit pcb 〉

Self diagnosis symbol Code	Green	Red				DIAGNOSIS
	Micro-computer normal -ED-A	Malfunction detection				
		LED 1	LED 2	LED 3	LED 4	
—	●	●	●	●	●	Normal → Check indoor units
H98,H99,F17	●	☉	●	☉	☉	Indoor high pressure protection or freeze-up operating unit or standby unit
F97	●	☉	●	☉	●	Compressor overheating or high discharge
F93	●	●	☉	☉	●	Compressor abnormal revolution
F98	●	●	☉	●	☉	Total running current protection
H16,H17	●	☉	☉	●	●	Abnormal temp. sensors or Current Transformer (*2)
—	●	☉	☉	●	☉	Control box overheating (Not abnormal)
H34	●	●	●	●	☉	Power transistor module overheating
F99	●	●	●	☉	●	DC peak detection (*2)
F91	●	●	●	☉	☉	Refrigerant cycle abnormality (*2)
F90	●	☉	●	●	☉	Low voltage power supply to main circuit
F11	●	☉	●	●	●	4-Way valve switching failure
F97	●	☉	☉	☉	☉	Outdoor fan motor mechanism lock
—	☉	—	—	—	—	Note 1
—	●	—	—	—	—	Power supply fault or (*2)

Green	Normally flashing	☉	Flashing
Red	Normally OFF	●	OFF
☉	ON	—	Irrelevant

Notes 1. Turn the power off and then on again. If the LED-A(green) turn on, the outdoor unit pcb is faulty.

2. Diagnosis marked \* does not apply to some cases.

For details, refer to the service manual.

## 9 Self Diagnosis Display

### 9.1. Breakdown Self Diagnosis Function (Three Digits Alphanumeric Code)

- Once abnormality has been detected during operation, the unit will immediately stop its operation. (Timer LED blinks.)
- Although timer LED goes off when power supply is turned off, if the unit is operated under a breakdown condition, the LED will light up again.
- In operation after breakdown repair, error code is not displayed. The last error code (abnormality) will be saved in IC memory.

- **Timer LED Blinking in Abnormal Operation:**

1. Automatically stops the operation.
2. Timer LED on display of the indoor unit blinks.
3. The LED will be off if the unit is turned off or the Error RESET button on the remote controller is pressed.

- **To display memorized error (Protective operation) status:**

1. Turn the unit on.
2. Press the CHECK button on the remote controller for continuously 5 seconds or more with a pointed object to appear "--" on the display.
3. Press the "TIMER" ▲ or ▼ button on the remote controller to appear "H00" on the display. Signal is transmitted to the main unit.
4. Press the "TIMER" ▲ button (When the ▼ button is pressed, the display goes back.) repeatedly and slowly until Beeps sound (about 5 seconds intermittently) is heard from main unit.
5. Then, displayed error code matches to the error code saved in unit memory. The power LED on the main unit also lights up.

**Note:** When the CHECK button is pressed continuously for 5 seconds again, or when no operation continues for 30 seconds, or when the RESET button on remote controller is pressed with a pointed object, the display is cancelled.

- **To clear memorized error (Protective operation) status after repair:**

1. Press the AUTO button in main unit continuously for 5 seconds or more and release it. (Test run / Pump down operation: Beep sound)
2. Press the CHECK button on remote controller for about 1 second with a pointed object to transmit signal to main unit. A beep sound is heard from main unit and the data is cleared.

- **Temporary Operation (Depending on breakdown status)**

1. Press the ON/OFF button after selecting Cooling or Heating operation. (Receiving Beep sound is heard and the TIMER LED blinks.)
2. The unit can temporarily be used until repaired.

#### Duct Type

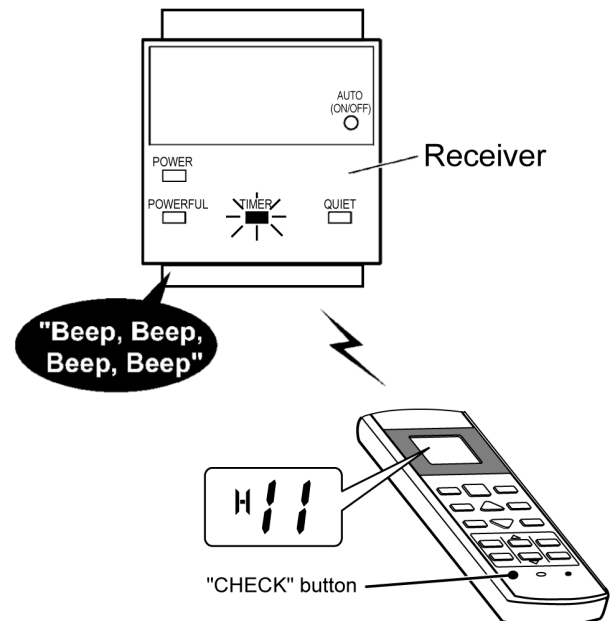
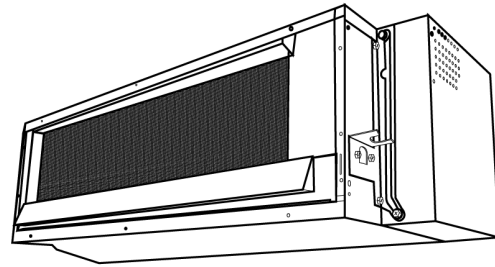

Error Code	Operation	Temporary items
H23	Cooling	Emergency Operation with limited power
H27, H28	Cooling, Heating	

## 9.2. Error Code

Symbol	Diagnosis	Diagnosis method
H11	Indoor / Outdoor abnormal communication	This error occurs when indoor/outdoor unit communication fails to be established after 30 seconds or more. <b>&lt;Diagnosis checkpoint&gt;</b> 1. Measure the voltage of the indoor/outdoor unit communication cables, and check whether the voltage is being supplied properly to the outdoor unit or whether it is being returned from the outdoor unit to the indoor units.
H12	Indoor unit capacity unmatched	This error occurs when wrong in the total connection capacity and wrong connection in each capacity. The error is determined within 2 minutes after the power is turned on. <b>&lt;Diagnosis checkpoint&gt;</b> 1. Check the total capacity of the units connected and check that the models are compatible for connection.
H14	Intake air temp. sensor	This error occurs when the intake air temperature has exceeded above 46°C continuously for 2 minutes or dropped below -54°C continuously for 5 seconds during operation. <b>&lt;Diagnosis checkpoint&gt;</b> 1. This error occurs when a temperature which is impossibly high or low from a normal standpoint has been detected. Check the sensor, and if open-circulating (more than 500k ohms) or short-circulating (less than 6.5k ohms) is not found, defective contact of the connector is possible.
H16	Outdoor Current Transformer	When the total current has dropped below the set current level continuously for 20 seconds during operation beyond the set capacity, operation is stopped. Three minutes later, operation is started up again, and when the trouble occurs on 4 successive occasions, the error occurs (the timer lamp blinks). <b>&lt;Diagnosis checkpoint&gt;</b> 1. Check the refrigerating cycle: Gas may be leaking (the amount of refrigerant is extremely low). 2. Check the control P.C. Board: Check for a broken wire (open-circuit) in the current transformer. (If open-circuit is found, replace the control P.C. Board.) In the case of a scroll compressor (DC motor), H16 is detected only when the regular compressor is operating.
H19	Indoor fan motor mechanism lock	<ul style="list-style-type: none"> <li>• High-voltage PWM: When a state in which the fan motor speed is not synchronized with the control signal has been detected on 7 successive occasions:</li> <li>• Low-voltage PAM: When the fan lock detection signal has been detected on 7 successive occasions or it has been detected continuously for 25 seconds or when a state in which the fan motor speed is not synchronized with the control signal has been detected on 7 successive occasions:</li> </ul> The error occurs (the timer lamp blinks). <b>&lt;Diagnosis checkpoint&gt;</b> 1. Check the nature of the fan lockup trouble. 2. Check for disconnections of the fan motor connectors and for defects in contact, in the fan motor and in the control P.C. Board.
H21	Indoor float switch abnormality	Error occurs when the float switch is open for 150 seconds. <b>&lt;Diagnosis checkpoint&gt;</b> 1. Drain blockage 2. Check the conductivity of float switch. 3. Check that the resistance of the drain motor is about 200 ohms.
H23	Indoor heat exchanger temp. sensor	This error occurs when a temperature of under approximately -40°C or above approximately 80°C has been detected by the heat exchanger temperature sensor continuously for 5 seconds. (This error is not detected during de-icing.) <b>&lt;Diagnosis checkpoint&gt;</b> 1. This error occurs when a temperature which is impossibly high or low from a normal standpoint has been detected. Check the sensor, and if open-circuit (more than 500k ohms) or short-circuit (less than 2.5k ohms) is not found, defective contact of the connector or a defective control P.C. Board is possible.
H27	Outdoor air temp. sensor	This error occurs when a temperature of under approximately -40°C or above approximately 150°C has been detected by the outdoor air temperature sensor for 2 to 5 seconds. (This error is not detected during de-icing.) <b>&lt;Diagnosis checkpoint&gt;</b> 1. This error occurs when a temperature which is impossibly high or low from a normal standpoint has been detected. Check the sensor, and if open-circuit (more than 500k ohms) or short-circuit (less than 0.5k ohms) is not found, defective contact of the connector or a defective control P.C. Board is possible.
H28	Outdoor heat exchanger temp. sensor 1	This error occurs when a temperature of under approximately -60°C or above approximately 110°C has been detected by the heat exchanger temperature sensor for 2 to 5 seconds. (This error is not detected during de-icing.) <b>&lt;Diagnosis checkpoint&gt;</b> 1. This error occurs when a temperature which is impossibly high or low from a normal standpoint has been detected. Check the sensor, and if open-circuit (more than 500k ohms) or short-circuit (less than 0.5k ohms) is not found, defective contact of the connector or a defective control P.C. Board is possible.

Symbol	Diagnosis	Diagnosis method
H30	Outdoor discharge pipe temp. sensor	<p>Disconnected discharge sensor</p> <ul style="list-style-type: none"> <li>When the condensation temperature is higher than the discharge temperature + (plus) 6°C, a sensor disconnection is detected, operation stops, and the error occurs (the timer lamp blinks).</li> </ul> <p><b>&lt;Diagnosis checkpoint&gt;</b></p> <ol style="list-style-type: none"> <li>This error occurs when a temperature which is impossibly high or low from a normal standpoint has been detected.</li> </ol> <p>Check the sensor, and if open-circuit (more than 500k ohms) or short-circuit (less than 0.5k ohms) is not found, defective contact of the connector or a defective control P.C. Board is possible.</p>
H32	Outdoor heat exchanger temp. sensor 2 (discharge pipe temp.)	<p>This error occurs when a temperature of under approximately -60°C or over approximately 110°C has been detected continuously for 2 to 5 seconds by the outlet temperature sensor of the heat exchanger.</p> <p><b>&lt;Diagnosis checkpoint&gt;</b></p> <ol style="list-style-type: none"> <li>This error occurs when a temperature which is impossibly high or low from a normal standpoint has been detected.</li> </ol> <p>Check the sensor, and if open-circuit (more than 500k ohms) or short-circuit (less than 0.5k ohms) is not found, defective contact of the connector or a defective control P.C. Board is possible.</p>
H34	Outdoor heatsink temp. sensor	<p>This error occurs when a temperature of under -43°C or above 80°C has been detected by the outdoor unit radiator fin sensor continuously for 2 seconds.</p> <p><b>&lt;Diagnosis checkpoint&gt;</b></p> <ol style="list-style-type: none"> <li>This error occurs when a temperature which is impossibly high or low from a normal standpoint has been detected.</li> </ol> <p>Check the sensor, and if open-circuit (more than 500k ohms) or short-circuit (less than 0.5k ohms) is not found, defective contact of the connector or a defective control P.C. Board is possible.</p>
H35	Drainage or drain pump abnormality	<p>This error occurs if the float switch is open three times for 10 seconds or more during a twenty-minute period.</p> <p><b>&lt;Diagnosis checkpoint&gt;</b></p> <ol style="list-style-type: none"> <li>Drain blockage</li> <li>Check the conductivity of float switch.</li> <li>Check that the resistance of the drain motor is about 200 ohms.</li> </ol>
H36	Outdoor gas pipe temp. sensor	<p>This error occurs when a temperature of under -45°C or above approximately 149°C has been detected by the outdoor unit gas side pipe temperature sensor continuously for 2 to 5 seconds.</p> <p><b>&lt;Diagnosis checkpoint&gt;</b></p> <ol style="list-style-type: none"> <li>This error occurs when a temperature which is impossibly high or low from a normal standpoint has been detected.</li> </ol> <p>Check the sensor, and if open-circuit (more than 500k ohms) or short-circuit (less than 0.5k ohms) is not found, defective contact of the connector or a defective control P.C. Board is possible.</p>
H37	Outdoor liquid pipe temp. sensor	<p>This error occurs when a temperature of under -45°C or above 149°C has been detected by the outdoor unit liquid side pipe temperature sensor continuously for 2 seconds.</p> <p><b>&lt;Diagnosis checkpoint&gt;</b></p> <ol style="list-style-type: none"> <li>This error occurs when a temperature which is impossibly high or low from a normal standpoint has been detected.</li> </ol> <p>Check the sensor, and if open-circuit (more than 500k ohms) or short-circuit (less than 0.5k ohms) is not found, defective contact of the connector or a defective control P.C. Board is possible.</p>
H39	Abnormal indoor operating unit or standby units	<p>This error occurs in rooms other than one in which indoor freezing error has occurred when the pipes have been connected incorrectly, when an outdoor expansion valve is defective or when an expansion valve connector has become disconnected.</p>
H97	Outdoor fan motor mechanism lock	<p>When the fan motor speed detected when its maximum output is demanded is below 30 rpm. continuously for 15 seconds, the fan motor stops for 3 minutes and then restarted.</p> <p>When this happens on 16 occasions (the error is cleared when the value is normal for 5 minutes), the H97 diagnostic symbol is stored in the memory, and the fan motor stops.</p> <p><b>&lt;Diagnosis checkpoint&gt;</b></p> <ol style="list-style-type: none"> <li>Check the nature of the fan lockup error.</li> <li>Check for disconnections of the fan motor connectors and for defects in contact, in the fan motor and in the control P.C. Board.</li> </ol>
H98	Indoor high pressure protection	<p>The restriction on the compressor frequency is started when the temperature of the indoor unit heat exchanger source is between 50°C and 52°C, the compressor stops at a temperature from 62°C to 65°C, it is restarted 3 minutes later at below 62°C to 65°C, and the restriction on the compressor frequency is released at a temperature between 48°C and 50°C. (No error occurs.)</p> <p><b>&lt;Diagnosis checkpoint&gt;</b></p> <ol style="list-style-type: none"> <li>Check the indoor unit heat exchanger temperature sensor (check for changes in its characteristics and check its resistance): Symptoms include no hot start when operation is started, a failure of the thermostat to turn on (no outdoor unit operation). And, frequent repetition of stopping and startup.</li> <li>Check also for short-circuits indoors and clogging of the air filters.</li> </ol>

Symbol	Diagnosis	Diagnosis method
H99	Indoor operating unit freezing	<p>The restriction on the compressor frequency is started when the indoor unit heat exchanger temperature is between 8°C and 12°C. Operation stops if a temperature below 0°C continues for 6 minutes. Three minutes later, operation is started up at a temperature from 3°C to 8°C. The restriction on the compressor frequency is released at a temperature between 13°C and 14°C.</p> <p><b>&lt;Diagnosis checkpoint&gt;</b></p> <ol style="list-style-type: none"> <li>1. A cooling or dry mode operation conducted at a low outside air temperature is mainly possible: this is not indicative of any malfunctioning.</li> </ol> <p>If the outdoor air temperature rises during automatic operation in the winter months, the dry mode operation is selected. The H99 diagnostic display also appears at such a time.</p> <ol style="list-style-type: none"> <li>2. Check the refrigerating cycle: Gas may be leaking (the amount of refrigerant is low) or a pipe may be broken, etc.</li> <li>3. Check also for short-circuits indoors and clogging of the air filters.</li> </ol>
F11	4-way valve switching failure	<p>When a difference of 0°C to 5°C has been detected between the outdoor unit heat exchanger temperature and liquid side pipe temperature on 5 occasions, the error occurs.</p> <p><b>&lt;Diagnosis checkpoint&gt;</b></p> <ol style="list-style-type: none"> <li>1. Check the 4-way valve coil: Check that no power is supplied to the coil during cooling and dry mode operations, and that power is supplied during heating operation. Inspect the coil for broken wires (open-circuit).</li> <li>2. If the coil trouble-free, the switching action of the 4-way valve may be defective.</li> </ol>
F17	Indoor standby units freezing	<p>When the difference of an intake temperature (room temperature sensor) and the indoor unit heat exchanger temperature (piping sensor) is higher than 10°C or an indoor unit heat exchanger temperature of below -1°C has been detected continuously for 5 minutes, operation stops. Three minutes later, it is started up, and the error occurs when this has occurred on 3 consecutive occasions.</p> <p><b>&lt;Diagnosis checkpoint&gt;</b></p> <ol style="list-style-type: none"> <li>1. Check the refrigerating cycle: Expansion valve leakage</li> <li>2. Check the indoor unit pipe temperature sensor. (Check for changes in its characteristics and check its resistance.)</li> </ol>
F90	PFC circuit protection	<p>When a DC voltage over 393V to 424V has been detected on 16 occasions, this error occurs.</p> <p><b>&lt;Diagnosis checkpoint&gt;</b></p> <ol style="list-style-type: none"> <li>1. To check whether the shutting valve has been left close by mistake, operation is performed for one to several minutes after the compressor has started up, F93 is stored in the memory as the symptom, and operation stops.</li> <li>2. Check the inverter circuit (for open-circuiting) in the control P.C. Board: Check the IPM base current (6 locations) within 3 minutes after the power has been turned back on. As the symptom, F93 is stored in the memory 30 seconds after the compressor has started up, and operation stops. The error occurs after 4 restarts.</li> <li>3. Check for broken wires (for open-circuiting) in the compressor winding: Approximately 1 ohm under normal conditions for each phase (same symptom as in 2.)</li> <li>4. Check the power supply voltage has been fluctuating or not.</li> </ol>
F91	Refrigeration cycle abnormality	<p>When the compressor frequency is above 55 Hz and the current drops below the prescribed level continuously for 7 minutes, operation stops, and it is restarted 3 minutes later.</p> <p>When the compressor discharge temperature has exceeded the setting and the expansion valve has remained fully open for 80 seconds, operation stops, and it is restarted 3 minutes later.</p> <p>When the stopping described above has occurred on 4 occasions, operation stops, and the error occurs.</p> <p><b>&lt;Diagnosis checkpoint&gt;</b></p> <ol style="list-style-type: none"> <li>1. Check the refrigerating cycle: Gas may be leaking (more than one-half of the volume of the gas has gone). The diagnosis displays resulting from a gas leak generally change in the following sequence depending on the extent of the gas leak: H99 → F97 → F91 → H16.</li> </ol> <p>The range of this error (F91) is limited. (Compressor protection at the start of the season)</p>
F93	Compressor abnormal revolution	<p>When a state in which the rotation of the compressor is not synchronized with the control signal has been detected on 8 successive occasions, operation stops, and the error occurs.</p> <p><b>&lt;Diagnosis checkpoint&gt;</b></p> <ol style="list-style-type: none"> <li>1. To check whether the shutting valve has been left close by mistake, operation is performed for one to several minutes after the compressor has started up, F93 is stored in the memory as the symptom, and operation stops.</li> <li>2. Check the inverter circuit (for open-circuit) in the control P.C. Board: Check the IPM base current (6 locations) within 3 minutes after the power has been turned back on. As the symptom, F93 is stored in the memory 30 seconds after the compressor has started up, and operation stops. The error occurs after 4 restarts.</li> <li>3. Check for broken wires (open-circuit) in the compressor winding: Approximately 1 ohm under normal conditions for each phase (same symptom as in 2.)</li> </ol>
F96	IPM (Power transistor module) or compressor overheating	<p>When error occurs from the electrical parts radiation fin temperature sensor and OLP output during operation, operation stops, and it is restarted 3 minutes later. If the trouble occurs on 4 occasions, operation stops, and the error occurs.</p> <p><b>&lt;Diagnosis checkpoint&gt;</b></p> <ol style="list-style-type: none"> <li>1. Something may be interfering with the dissipation of the heat outdoors or the outdoor unit fan may be defective. (The outdoor unit fan is not running.)</li> <li>2. Defective IPM (Outdoor unit control P.C. Board)</li> <li>3. Gas leaks. Shutting valve is not opened.</li> </ol>

Symbol	Diagnosis	Diagnosis method
F97	Compressor high discharge temperature	<p>This error occurs and operation stops when this happens on 6 occasions (it is cleared when the operation is normal for 20 minutes).</p> <p><b>&lt;Diagnosis checkpoint&gt;</b></p> <ol style="list-style-type: none"> <li>1. Check the refrigerating cycle: Gas may be leaking (The amount of refrigerant is low). The stopping of the outdoor unit from time to time is a symptom of this error.</li> <li>2. When operation stops with this error occurs, check the compressor temperature sensor. (Check for changes in its characteristics and check its resistance.)</li> <li>3. Something may be interfering with the dissipation of the heat outdoors or the outdoor unit fan may be defective. (The fan will not run because of open-circuiting.)</li> </ol> <p>(The protection may be activated by an overload, and the F97 error will remain stored in the memory.)</p>
F98	Total running current protection	<p>When the total current exceeds the setting (17A to 20A), frequency control is started, and if it then exceeds the setting, operation stops, and the error occurs.</p> <p><b>&lt;Diagnosis checkpoint&gt;</b></p> <ol style="list-style-type: none"> <li>1. Check the AC voltage at the outdoor unit terminal board during operation: The voltage drop must be within 5% of the voltage when operation has stopped (<math>\pm 10\%</math> of rated voltage even during operation). If the voltage drop exceeds 5% of if the voltage changes suddenly, inspect whether the power supply cord and indoor/outdoor unit connection cables are too long or too small in diameter, etc.</li> <li>2. Check whether something is interfering with the dissipation of the heat exchanger outdoors (during cooling operation): Normally, the capacity is limited by the current so that outdoor unit doesn't stop, and the diagnostic display does not appear.</li> </ol>
F99	DC peak detection	<p>When "Output current error", which occurs when the prescribed current level is exceeded, has occurred on 16 consecutive occasions, operation stops, and the error occurs.</p> <p><b>&lt;Diagnosis checkpoint&gt;</b></p> <ol style="list-style-type: none"> <li>1. Check whether the compressor is defective (locked up or shorted winding). Check the outdoor unit control P.C. Board.</li> </ol>

# 10 Installation Information

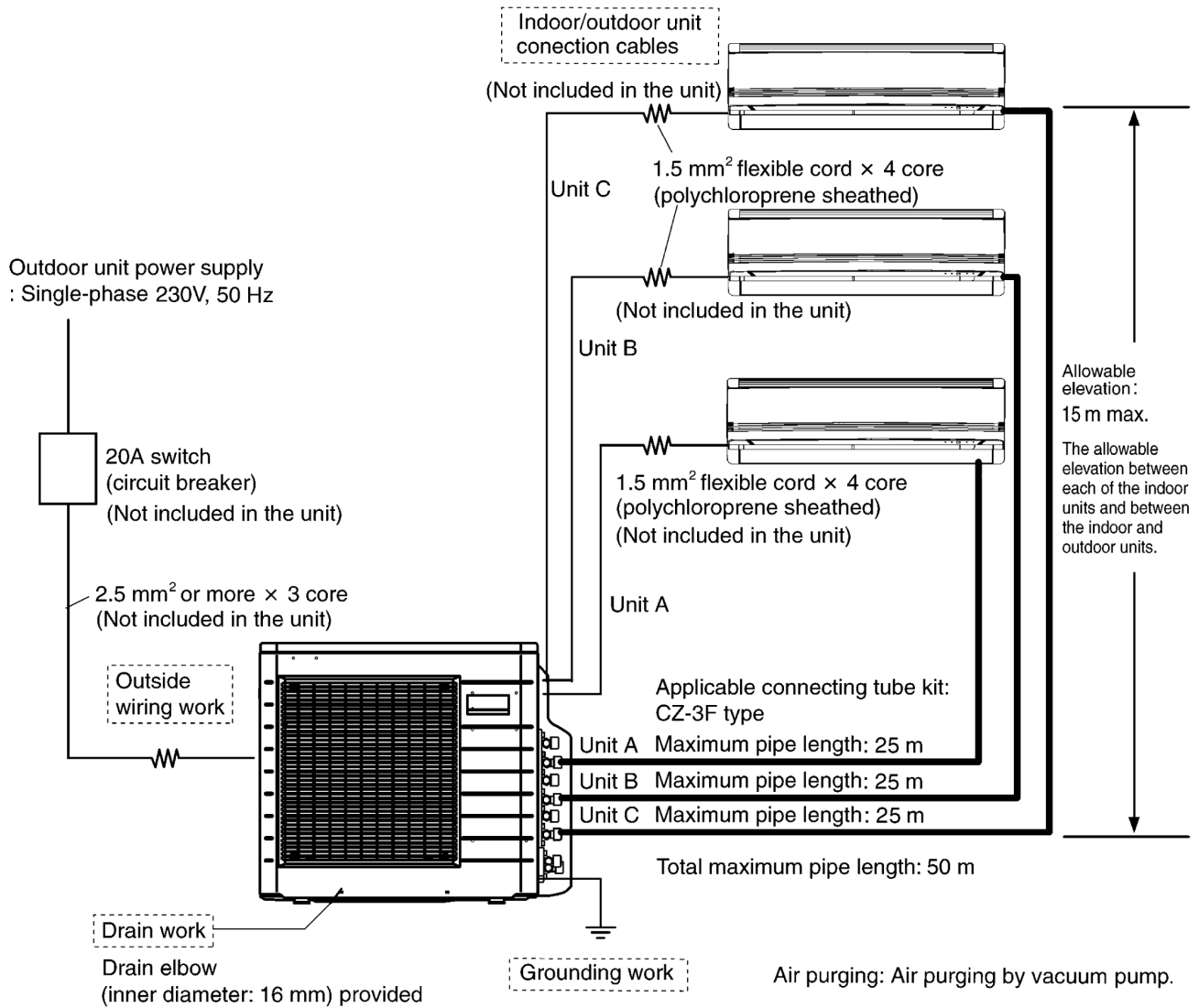

# 11 Installation Instructions

## Accessories

Accessories supplied with the outdoor unit: CU-3E18EBE

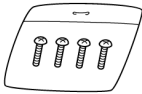
<p>(A) Drain plug</p>  <p>There is on the bottom packing case.</p>	1	<p>(B) Screw bag</p> <p>(For fixing electrical wire anchor bands)</p>  <p>There is on the bottom packing case.</p>	1
(C) Installation Manual	4	(D) Operation Manual	1

## Precautions for Selecting the Location

### Outdoor Unit

- 1) Choose a place solid enough to bear the weight and vibration of the unit, where the operation noise will not be amplified.
- 2) Choose a location where the hot air discharged from the unit or the operation noise, will not cause a nuisance to the neighbors of the user.
- 3) Avoid places near a bedroom and the like, so that the operation noise will cause no trouble.
- 4) There must be sufficient spaces for carrying the unit into and out of the site.
- 5) There must be sufficient space for air passage and no obstructions around the air inlet and the air outlet.
- 6) The site must be free from the possibility of flammable gas leakage in a nearby place. Locate the unit so that the noise and the discharged hot air will not annoy the neighbors.
- 7) Install units, power cords and inter-unit cables at least 3 meter away from television and radio sets. This is to prevent interference to images and sounds. (Noises may be heard even if they are more than 3 meter away depending on radio wave conditions.)
- 8) In coastal areas or other places with salty atmosphere of sulfate gas, corrosion may shorten the life of the air conditioner.
- 9) Since drain flows out of the outdoor unit, do not place under the unit anything which must be kept away from moisture.

#### NOTE

Cannot be installed hanging from ceiling or stacked.

## Outdoor Unit Installation Drawings

For installation of the indoor units, refer to the installation manual which was provided with the units.  
(The diagram shows a wall-mounted indoor unit.)

### ⚠ CAUTION

- Do not connect the embedded branch piping and the outdoor unit when only carrying out piping work without connecting the indoor unit in order to add another indoor unit later.  
Make sure no dirt or moisture gets into either side of the embedded branch piping.  
See "6 Refrigerant Piping Work" for details.
- It is impossible to connect the indoor unit for one room only. **Be sure to connect at least 2 rooms.**

CU-3E18EBE

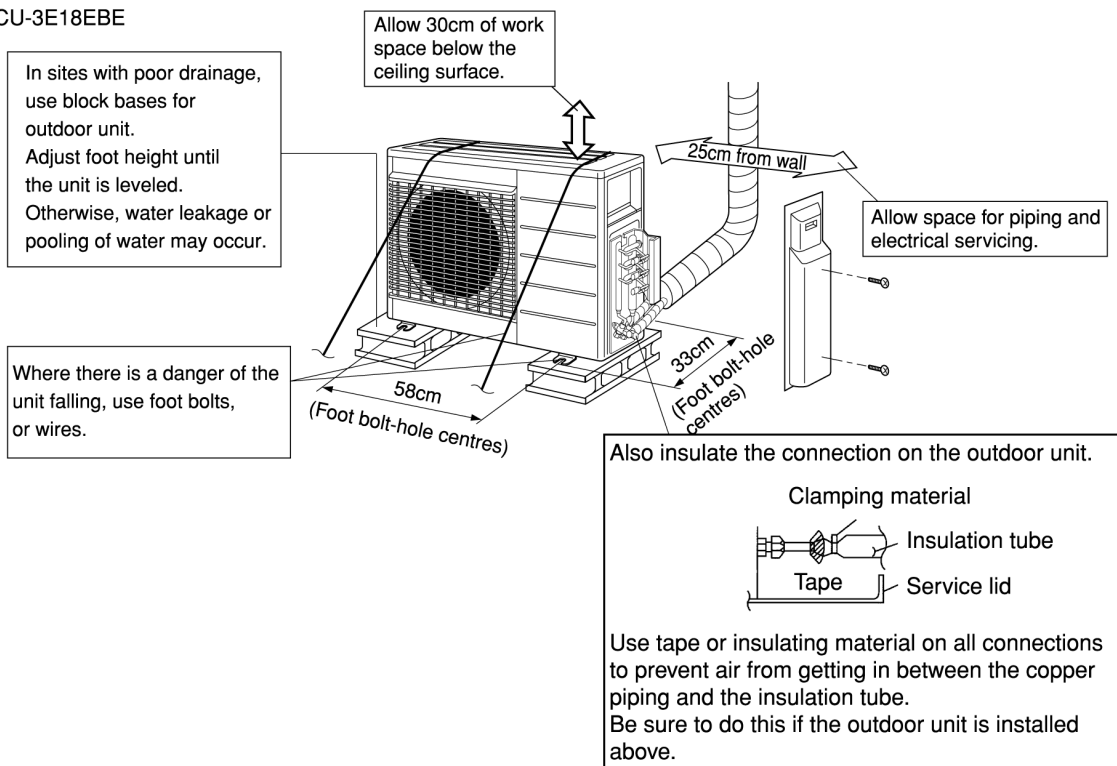

## Installation

- Install the unit horizontally.
- The unit may be installed directly on a concrete verandah or a solid place if drainage is good.
- If the vibration may possibly be transmitted to the building, use a vibration-proof rubber (field supply).

## Outdoor Unit Installation Guidelines

- Where a wall or other obstacle is in the path of outdoor unit's intake or exhaust airflow, follow the installation guidelines below.
- For any of the below installation patterns, the wall height on the exhaust side should be 1200mm or less.

### Wall facing one side

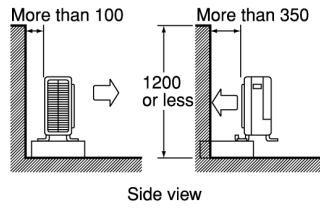

### Walls facing two sides

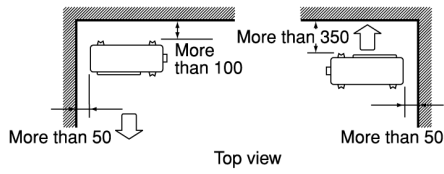

### Walls facing three sides

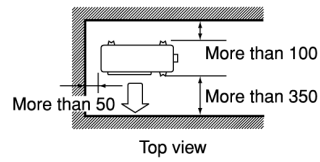

Unit: mm

## Selecting a location for installation of the indoor units

- The maximum allowable length of refrigerant piping, and the maximum allowable height difference between the outdoor and indoor units, are listed below.  
 (The shorter the refrigerant piping, the better the performance. Connect so that the piping is as short as possible.  
**Shortest allowable length per room is 3m.**)

Outdoor unit	CU-3E18EBE
Piping to each indoor unit	25m max.
Total length of piping between all units	50m max.

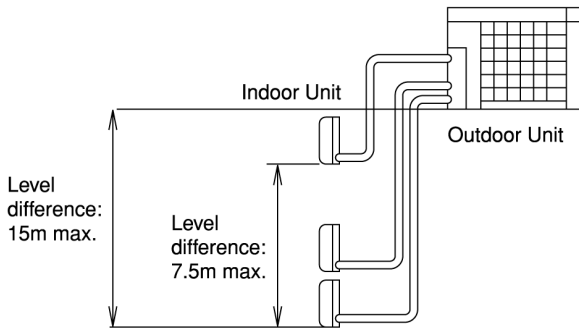

If the outdoor unit is positioned higher than the indoor units.

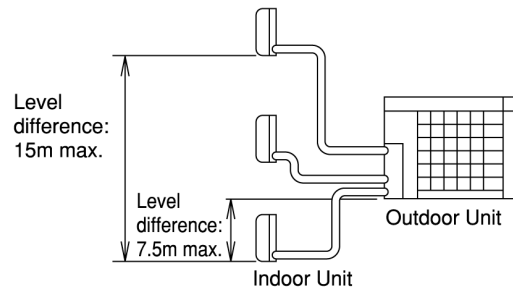

If the outdoor unit is positioned otherwise.  
 (If lower than one or more indoor units)

# 3P097711-5E (M05B111)

## Outdoor Unit

### 1 Installing Outdoor Unit

- When installing the outdoor unit, refer to “Precautions for Selecting the Location” and the “Outdoor Unit Installation Drawings”.
- If drain work is necessary, follow the procedures below.

### 2 Drain Work

(CU-3E18EBE)

- Use drain plug for drainage.
- If the drain port is covered by a mounting base or floor surface, place additional foot bases of at least 30mm in height under the outdoor unit's feet.
- In cold areas, do not use a drain hose with the outdoor unit. (Otherwise, drain water may freeze, impairing heating performance.)

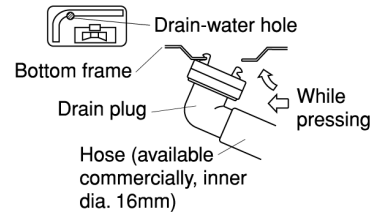

### 3 Refrigerant Piping

1. Align the centres of both flares and tighten the flare nuts 3 or 4 turns by hand. Then tighten them fully with the torque wrenches.
  - Use torque wrenches when tightening the flare nuts to prevent damage to the flare nuts and escaping gas.

Flare nut tightening torque	
Flare nut for $\phi 6.4$	14.2-17.2N·m (144-175kgf·cm)
Flare nut for $\phi 9.5$	32.7-39.9N·m (333-407kgf·cm)

Valve cap tightening torque
Liquid pipe 26.5-32.3N·m (270-330kgf·cm)

Service port cap tightening torque
10.8-14.7N·m (110-150kgf·cm)

2. To prevent gas leakage, apply refrigeration machine oil on both inner and outer surfaces of the flare. (Use refrigeration oil for R410A)

### 4 Purging Air and Checking Gas Leakage

- When piping work is completed, it is necessary to purge the air and check for gas leakage.

### 5 Charging with Refrigerant

- If the total length of piping for all rooms exceeds the figure listed below, additionally charge with **20g** of refrigerant (R410A) for each additional meter of piping.

Outdoor capacity class	CU-3E18EBE
Total length of piping for all rooms	30m

#### **CAUTION**

Even though the shut-off valve is fully closed, the refrigerant may slowly leak out; do not leave the flare nut removed for a long period of time.

## 6 Refrigerant Piping Work

### Cautions on Pipe Handling

- Protect the open end of the pipe against dust and moisture.
- All pipe bends should be as gentle as possible. Use a pipe bender for bending.  
(Bending radius should be 30 to 40mm or larger.)

### Selection of Copper and Heat Insulation materials

When using commercial copper pipes and fittings, observe the following:

- Insulation material: Polyethylene foam  
Heat transfer rate: 0.041 to 0.052W/mK (0.035 to 0.045kcal/mh°C)  
Refrigerant gas pipe's surface temperature reaches 110°C max.  
Choose heat insulation materials that will withstand this temperature.
- Be sure to insulate both the gas and liquid piping and to provide insulation dimensions as below.

Pipe size	Pipe insulation
O.D. : 6.4mm / Thickness : 0.8mm	I.D. : 8-10mm / Thickness : 10mm min.
O.D. : 9.5mm, 12.7mm / Thickness : 0.8mm	I.D. : 12-15mm / Thickness : 13mm min.
O.D. : 15.9mm / Thickness : 1.0mm	I.D. : 16-20mm / Thickness : 13mm min.

- Use separate thermal insulation pipes for gas and liquid refrigerant pipes.

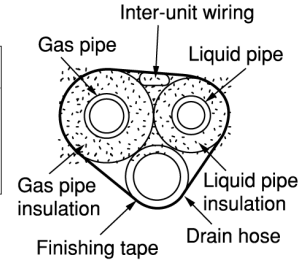
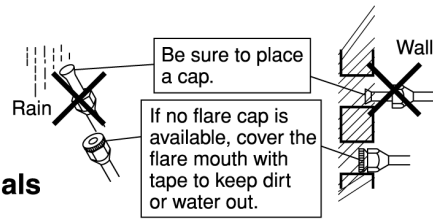

## 7 Flaring the Pipe End

1. Cut the pipe end with a pipe cutter.
2. Remove burrs with the cut surface facing downward so that the chips do not enter the pipe.
3. Put the flare nut on the pipe.
4. Flare the pipe.
5. Check that the flaring is properly made.

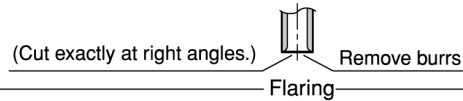

Set exactly at the position shown below.

Flare tool for R410A	Conventional flare tool	
	Clutch-type	Wing-nut type (Imperial-type)
A	0 ~ 0.5mm	1.0 ~ 1.5mm

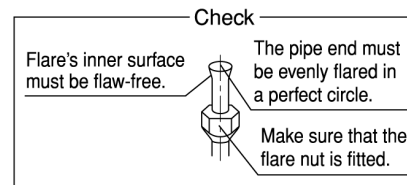

### ⚠ WARNING

Do not use mineral oil on flared part.  
Prevent mineral oil from getting into the system as this would reduce the lifetime of the units.  
Never use piping which has been used for previous installation. Only use parts which are delivered with the unit.  
Do never install a drier to this R410A unit in order to guarantee its lifetime.  
The drying material may dissolve and damage the system.  
Incomplete flaring may cause refrigerant gas leakage.

## Purging Air and Checking Gas Leakage

- When piping work is completed, it is necessary to purge the air and check for gas leakage.

### WARNING

- 1) Do not mix any substance other than the specified refrigerant (R410A) into the refrigeration cycle.
- 2) When refrigerant gas leaks occur, ventilate the room as soon and as much as possible.
- 3) R410A, as well as other refrigerants, should always be recovered and never be released directly into the environment.
- 4) Use a vacuum pump for R410A exclusively. Using the same vacuum pump for different refrigerants may damage the vacuum pump or the unit.

- If using additional refrigerant, perform air purging from the refrigerant pipes and indoor unit using a vacuum pump, then charge additional refrigerant.
- Use a hexagonal wrench (4mm) to operate the shut-off valve rod.
- All refrigerant pipe joints should be tightened with a torque wrench at the specified tightening torque.

(1) Connect projection side (on which worm pin is pressed) of charging hose (which comes from gauge manifold) to gas shut-off valve's service port.



(2) Fully open gauge manifold's low-pressure valve (Lo) and completely close its high-pressure valve (Hi). (High-pressure valve subsequently requires no operation.)



(3) Apply vacuum pumping. Check that the compound pressure gauge reads  $-0.1\text{MPa}$  ( $-76\text{cmHg}$ ). Evacuation for **at least 1 hour** is recommended.



(4) Close gauge manifold's low-pressure valve (Lo) and stop vacuum pump. (Leave as is for 4-5 minutes and make sure the coupling meter needle does not go back. If it does go back, this may indicate the presence of moisture or leaking from connecting parts. Repeat steps 2 – 4 after checking all connecting parts and slightly loosening the nuts.)



(5) Remove covers from liquid shut-off valve and gas shut-off valve.



(6) Turn the liquid shut-off valve's rod 90 degrees counterclockwise with a hexagonal wrench to open valve. Close it after 5 seconds, and check for gas leakage. Using soapy water, check for gas leakage from indoor unit's flare and outdoor unit's flare and valve rods. After the check is complete, wipe all soapy water off.



(7) Disconnect charging hose from gas shut-off valve's service port, then fully open liquid and gas shut-off valves. (Do not attempt to turn valve rod beyond its stop.)



(8) Tighten valve lids and service port caps for the liquid and gas shut-off valves with a torque wrench at the specified torques. See "3 Refrigerant Piping" for details.

# Wiring

## ⚠ WARNING

Do not use tapped wires, stand wires, extensioncords, or starbust connections, as they may cause overheating, electrical shock, or fire.

- Do not turn ON the safety breaker until all work is completed.
- (1) Strip the insulation from the wire (20mm).
  - (2) Connect the connection wires between the indoor and outdoor units **so that the terminal numbers match**. Tighten the terminal screws securely. We recommend a flathead screwdriver be used to tighten the screws.
    - Power supply cord :  $3 \times 2.5\text{mm}^2$  or more
    - Connecting cord between indoor and outdoor :  $4 \times 1.5\text{mm}^2$
  - (3) Pull the wire and make sure that it does not disconnect. Then fix the wire in place with a wire stop.

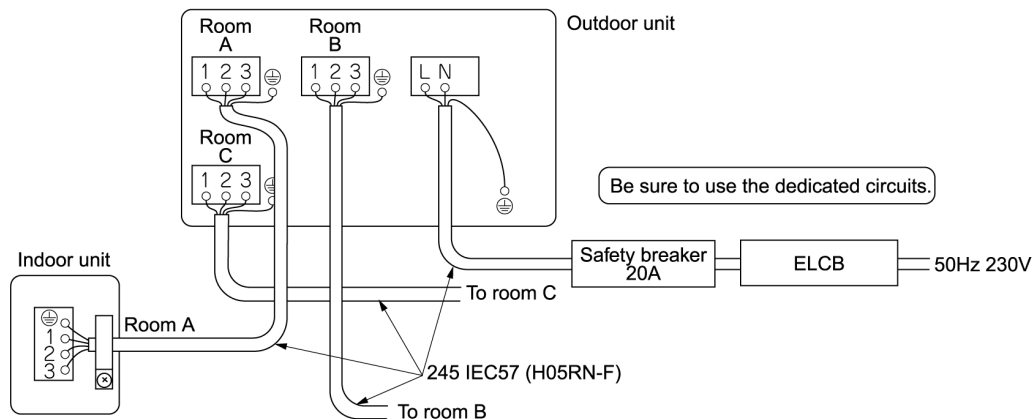

## Earth

This air conditioner must be earthed.  
For earthing, follow the applicable local standard for electrical installations.

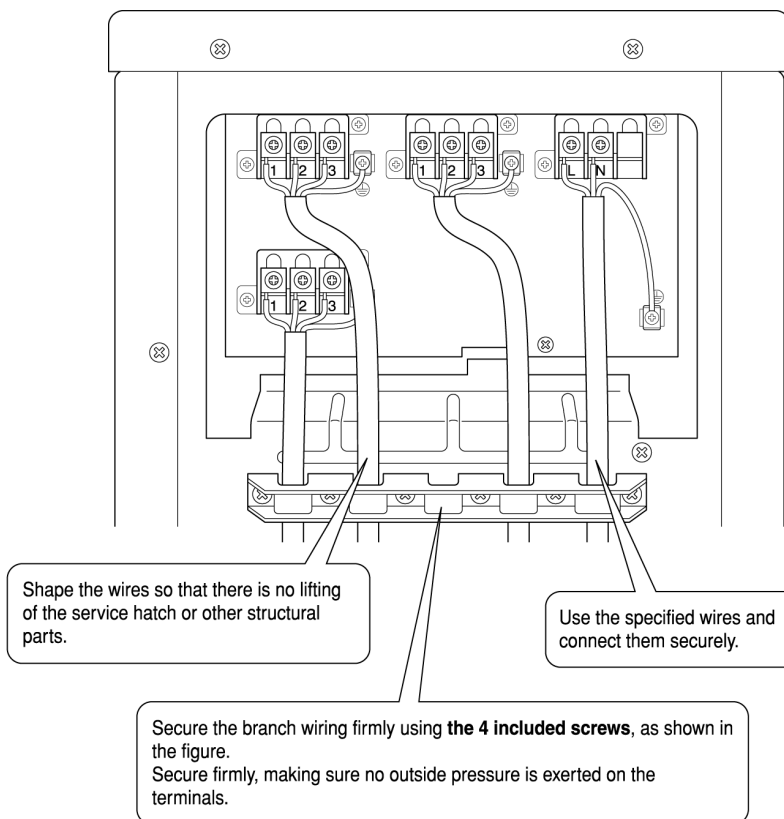

## Pump Down Operation

In order to protect the environment, be sure to pump down when relocating or disposing of the unit.

- (1) Remove the valve lid from liquid shut-off valve and gas shut-off valve.
- (2) Carry out forced cooling operation.
- (3) After five to ten minutes, close the liquid shut-off valve with a hexagonal wrench.
- (4) After two to three minutes, close the gas shut-off valve and stop forced cooling operation.

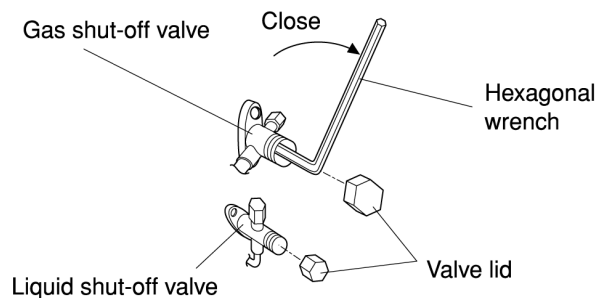

### Forced operation

- (1) Turn the Operation Mode switch (SW2) to "COOL".
- (2) Press the Forced Operation switch (SW1) to begin forced cooling. Press the Forced Operation switch (SW1) again to stop forced cooling.

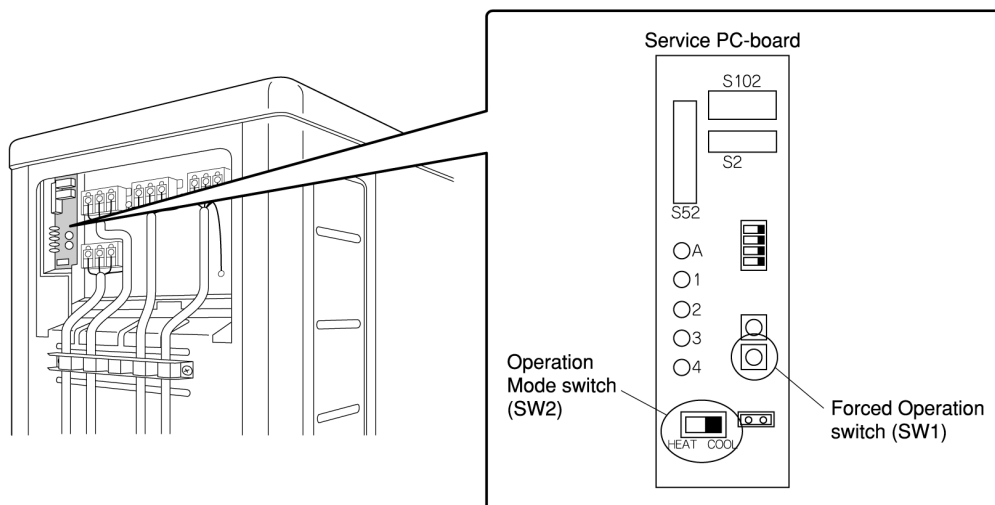

## Test Run and Final Check

- Before starting the test run, measure the voltage at the primary side of the safety breaker. Check that it is 230V.
- Check that all liquid and gas shut-off valves are fully open.
- Check that piping and wiring all match. The wiring error check can be conveniently used for underground wiring and other wiring that cannot be directly checked.

### Wiring error check

- This product is capable of automatic correction of wiring error.

Press the "wiring error check switch" on the outdoor unit service monitor print board. However, the wiring error check switch will not function for one minute after the safety breaker is turned on, or depending on the outside air conditions (See NOTE 2.).

Approximately 10 – 15 minutes after the switch is pressed, the errors in the connection wiring will be corrected.

The service monitor LEDs indicate whether or not correction is possible, as shown in the table below. For details about how to read the LED display, refer to the service guide.

Service PC-board

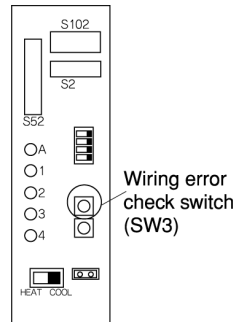

If self-correction is not possible, check the indoor unit wiring and piping in the usual manner.

LED	1	2	3	4	Message
Status	All Flashing				Automatic correction impossible
	Flashing		One after another		Automatic correction completed
	☀ (One or more of LEDs 1 to 4 are ON)				Abnormal stop [NOTE. 4]

### Wiring correct example

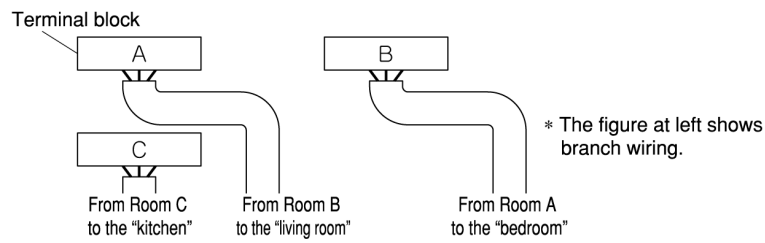

↓ Wiring error check

LED lighting sequence after a wiring correction.

Order of LED flashing: 2 → 1 → 3 → 4

### NOTE

- (1) For two rooms, LED 3 and 4 are not displayed, and for three rooms, LED 4 is not displayed.
- (2) If the outside air temperature is **5°C or less**, the wiring error check function will not operate.
- (3) After wiring error check operation is completed, LED indication will continue until ordinary operation starts. This is normal.
- (4) Follow the product diagnosis procedures. (Check the nameplate on the underside of the shut-off valve.)

- To test cooling, set for the lowest temperature. To test heating, set for the highest temperature. (Depending on the room temperature, only heating or cooling (but not both) may be possible.)
- After the unit is stopped, it will not start again (heating or cooling) for approximately 3 minutes.
- During the test run, first check the operation of each unit individually. Then also check the simultaneous operation of all indoor units.  
Check both heating and cooling operation.
- After running the unit for approximately 20 minutes, measure the temperatures at the indoor unit inlet and outlet. If the measurements are above the values shown in the table below, then they are normal.

	Cooling	Heating
Temperature difference between inlet and outlet	Approx. 8°C	Approx. 20°C

(When running in one room)

- During cooling operation, frost may form on the gas shut-off valve or other parts. This is normal.
- Operate the indoor units in accordance with the included operation manual. Check that they operate normally.

#### Items to check

Check item	Consequences of trouble	Check
Are the indoor units installed securely?	Falling, vibration, noise	
Has an inspection been made to check for gas leakage?	No cooling, no heating	
Has complete thermal insulation been done (gas pipes, liquid pipes, indoor portions of the drain hose extension)?	Water leakage	
Is the drainage secure?	Water leakage	
Are the ground wire connections secure?	Danger in the event of a ground fault	
Are the electric wires connected correctly?	No cooling, no heating	
Is the wiring in accordance with the specifications?	Operation failure, burning	
Are the inlets/outlets of the indoor and outdoor units free of any obstructions? Are the shut-off valves open?	No cooling, no heating	
Do the marks match (room A, room B) on the wiring and piping for each indoor unit?	No cooling, no heating	

#### ATTENTION

- Have the customer actually operate the unit while looking at the manual included with the indoor unit. Instruct the customer how to operate the unit correctly (particularly cleaning of the air filters, operation procedures, and temperature adjustment).
- Even when the air conditioner is not operating, it consumes some electric power. If the customer is not going to use the unit soon after it is installed, turn OFF the breaker to avoid wasting electricity.
- If additional refrigerant has been charged because of long piping, list the amount added on the nameplate on the reverse side of the shut-off valve cover.

# 12 Disassembly of Parts

## 12.1. Wall Type

### 12.1.1. Indoor Control Board Removal Procedures

1. Remove the Front Grille.

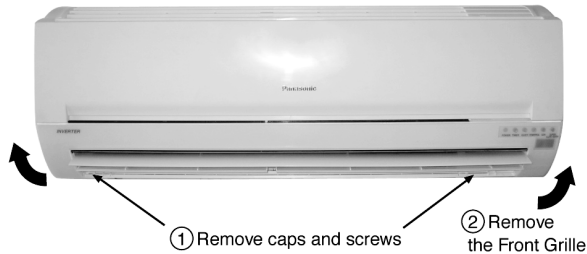

Fig. 1

2. Remove the Indoor Control Board.

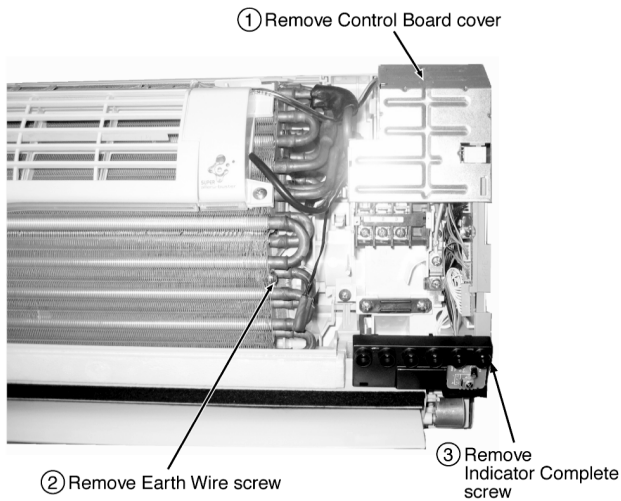

Fig. 2



Fig. 4

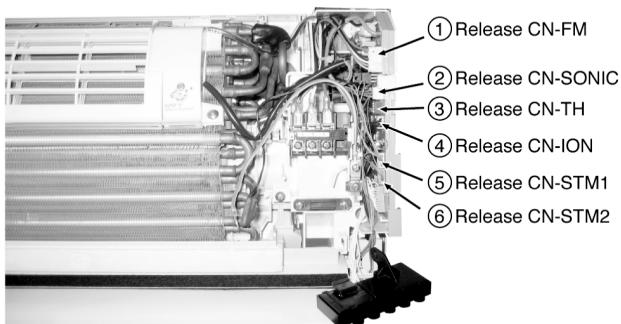

Fig. 3

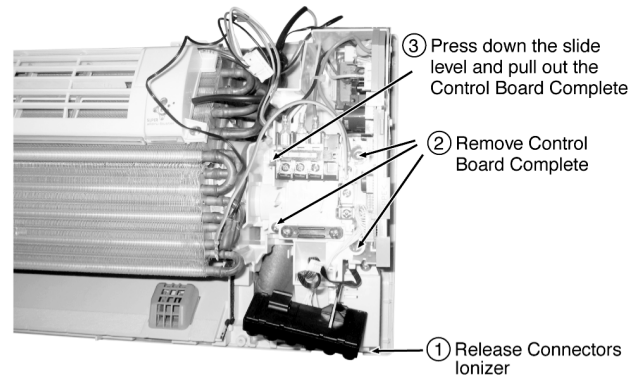

Fig. 5

## 12.1.2. Electronic Controller Removal Procedures

### 1. Remove Main Electronic Controller

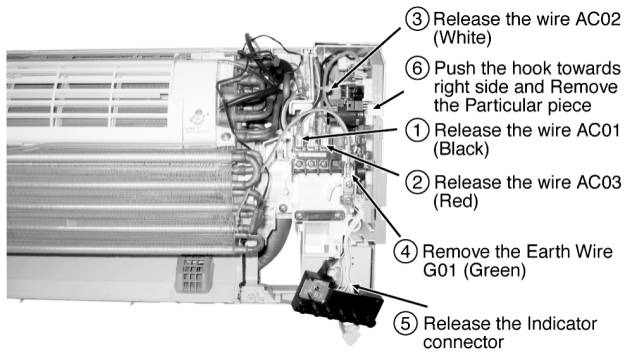

Fig. 6

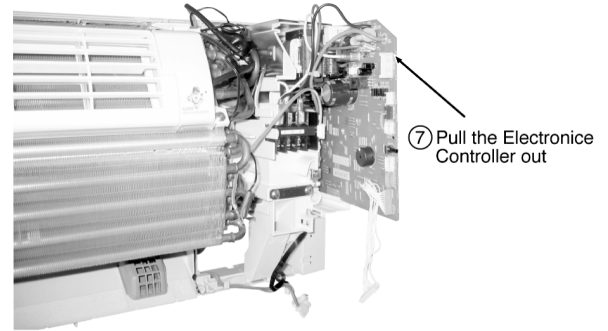

Fig. 7

## 12.1.3. Cross Flow Fan and Fan Motor Removal Procedures

### 1. Remove Cross Flow Fan and Fan Motor.

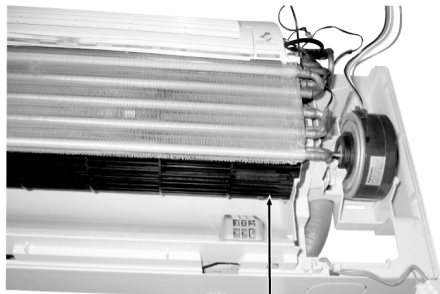

Fig. 8

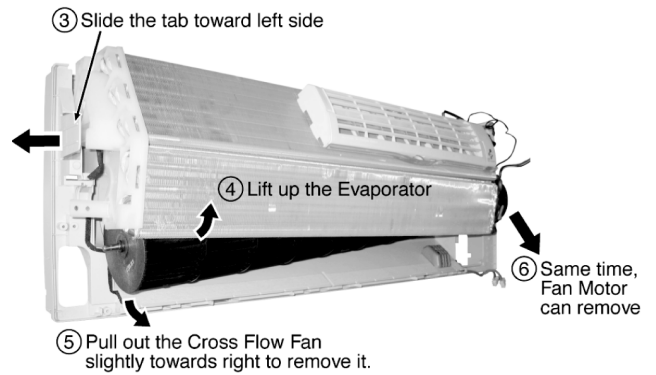

Fig. 10

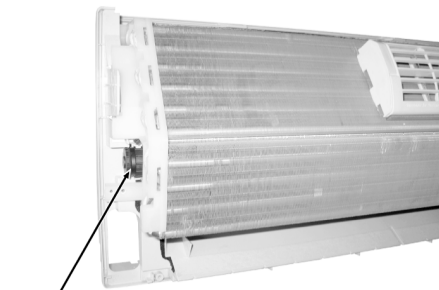
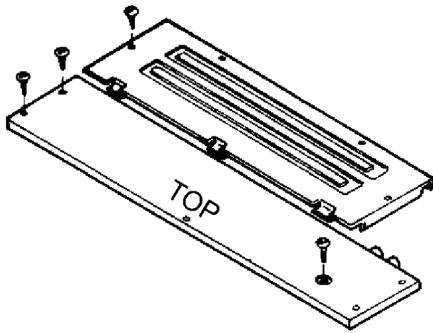

Fig. 9

## 12.2. Duct Type

### 12.2.1. Detaching the Upper and Inner Casing



- 1) Unscrew the 4 screws on the Upper and Inner Casing and detach them.

### 12.2.2. Detaching the Control Board

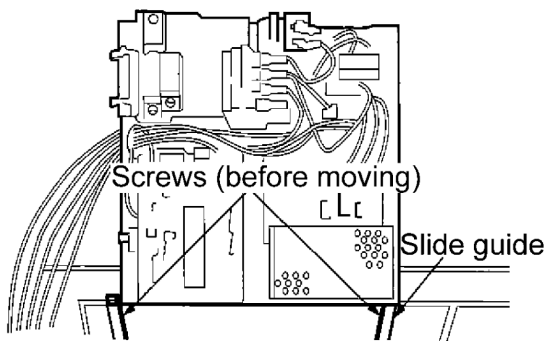

- 1) First detach the Upper and Inner Casing (14.2.1).
- 2) Unscrew the 2 screws on the Slide Guide.
- 3) Pull the board down following the Slide Guide.
- 4) Lift the Board up from the bottom, disengage the Catch holding the Board and open it.

### 12.2.3. Detaching the Fan

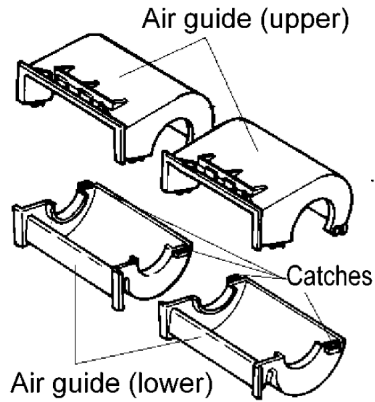

- 1) First detach the Upper and Inner Casing (14.2.1).
- 2) Disengage the 4 screws (2 each on the left and right) on the Air Guide.

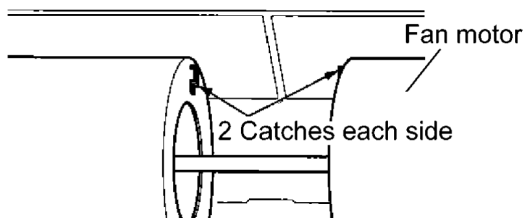

- 3) Use a 2.5 mm hexagonal wrench to loosen the bolt connecting the Fan Motor and Fan, detach the shaft connecting the Fan Motor and Fan, loosen the screw holding the Fan and detach the Fan.

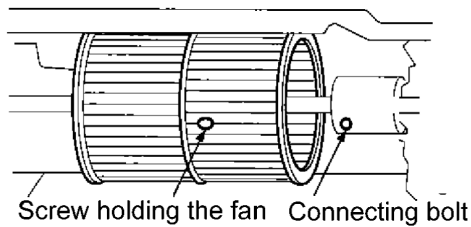

### 12.2.4. Detaching the Fan Motor and Drain Motor

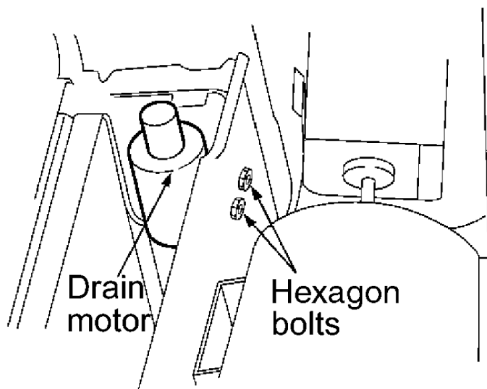

#### Fan Motor

- 1) First detach the upper and inner casing (14.2.1) and the Fan (14.2.3).
- 2) Unscrew the 4 screws holding the Fan Motor and detach it.

#### Drain Motor

- 1) First detach the Upper and Inner Casing (14.2.1) and the Fan (14.2.3).
- 2) From the Fan Motor side, undo the 2 hexagon bolts and detach the Drain Motor.

## 12.3. Ceiling Floor Type

### 12.3.1. Front Grille Removal Procedure

1. Remove the Intake Grille and Air Filter from the Front Grille (Fig. 1).

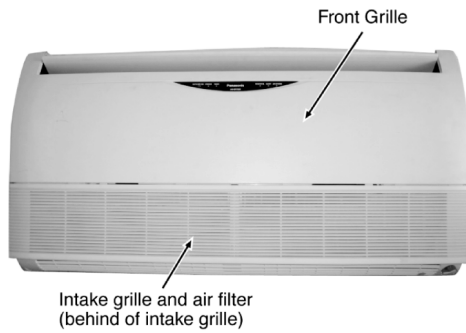

Fig. 1

2. Remove the Front Grille by removing the screws (Fig. 2).

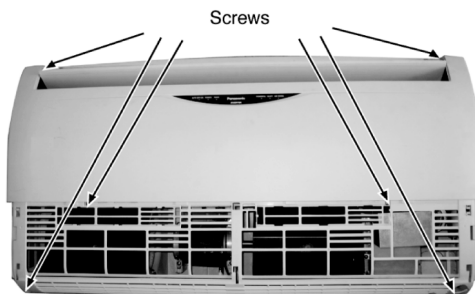

Fig. 2

3. Fan Motor and Control Board (Fig. 3).

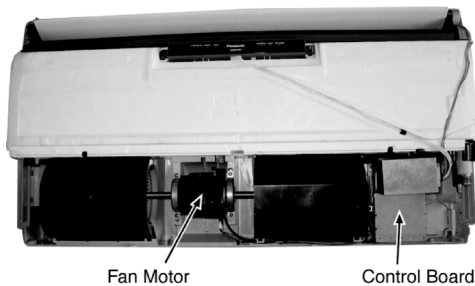

Fig. 3

### 12.3.2. Fan Motor Removal Procedure

1. Remove two Air Guider Blower Wheels (Fig. 4).

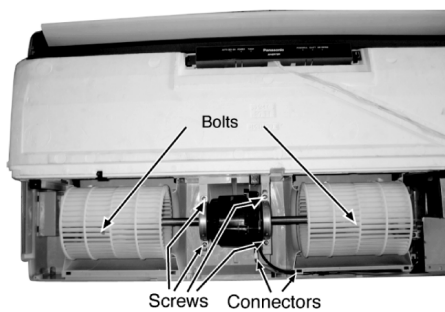

Fig. 4

2. Remove Fan Motor by:

- Releasing the connector Fan Motor (Fig. 5).
- Removing the Fan Motor supporter screws (Fig. 5).
- Removing the Blower Wheel bolts (Fig. 5).

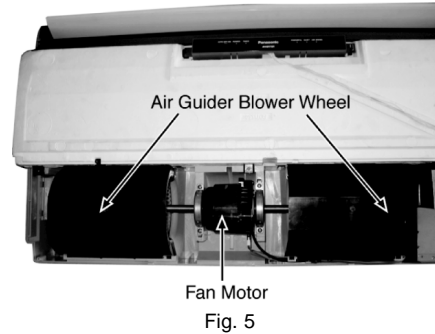

Fig. 5

### 12.3.3. Electronic Controller Removal procedure

1. Remove the Control Board Cover by removing the screws (Fig. 6).

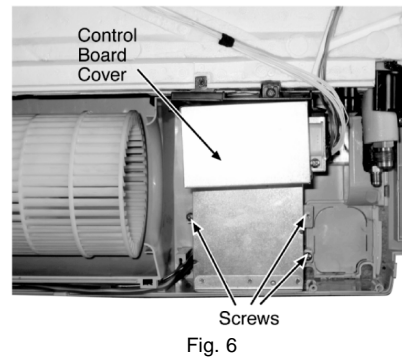

Fig. 6

2. Electronic Controller (Fig. 7).

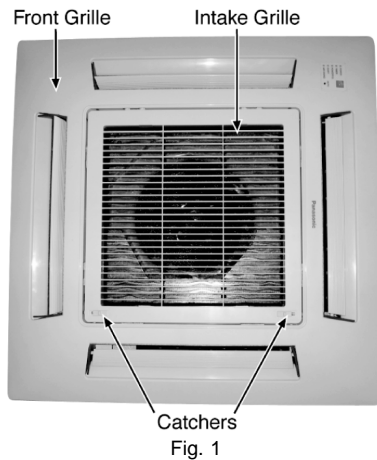

Fig. 7

## 12.4. Mini-Cassette Type

### 12.4.1. Disassembly of Parts

1. Open the Intake Grille from the Front Grille by moving the catchers to center (Fig. 1).



2. Remove the Control Board Cover by removing the screws (Fig. 2).

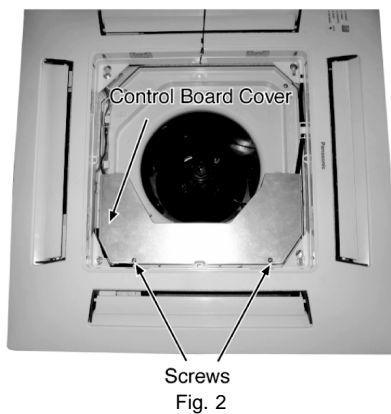

3. Release the following parts (Fig. 3):

- CN-STM1(WHT) connector
- CN-STM1(WHT) connector
- CN-STM2(YLM) connector
- CN-DISP(WHT) connector
- CN-FM(WHT) connector
- CN-TH1(WHT) connector
- CN-TH2(BLU) connector
- CN-DRMTR1(BLU) connector
- AC01(BLK), AC02(WHT) and CN-DRMTR2(RED) from Terminal Board
- GR01(GRN) screw
- Two T-BLK connectors
- CN-T1(WHT)
- CN-T2(YLW)

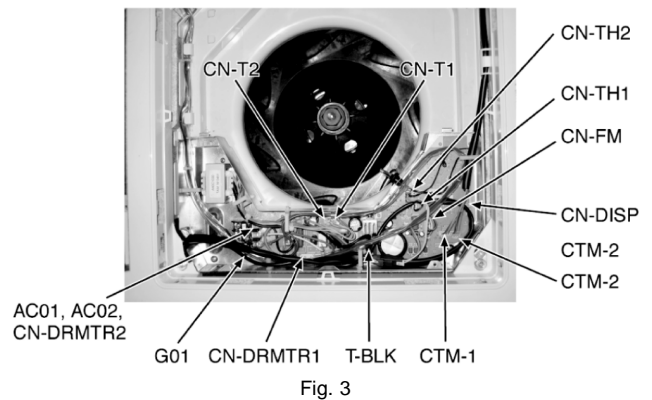

4. To remove the Electronic Controller, release the 6 hooks holding the Control Board (Fig. 4).

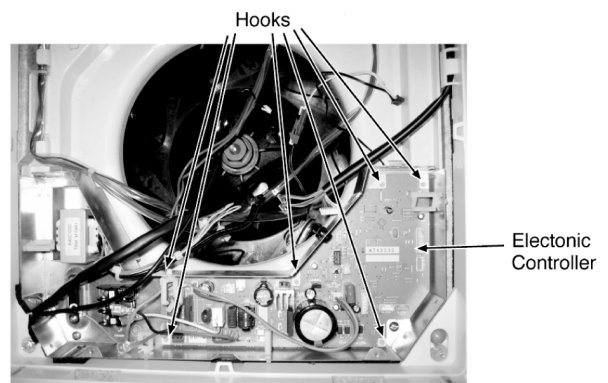

5. Remove the Front Grille by removing the screw A and screw B, C & D half way open (Fig. 5).

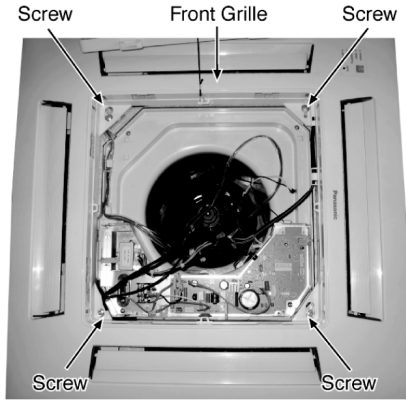

Fig. 5

7. Remove the Turbo Fan by removing the bolt (Fig. 7).

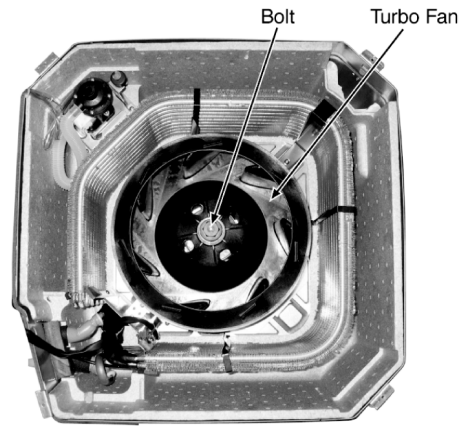

Fig. 7

6. Remove the Air Guider and Drain Pan complete by removing the screws (Fig. 6).

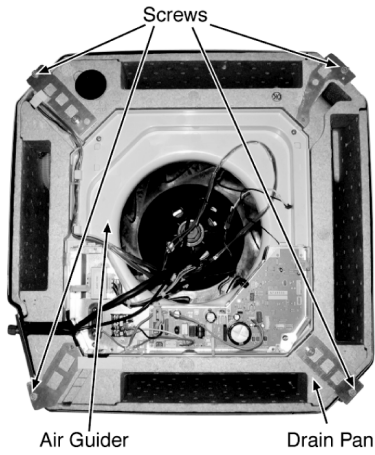

Fig. 6

8. Remove the Fan Motor by releasing the Fan Motor lead wire connectors and Fan Motor screws (Fig. 8).

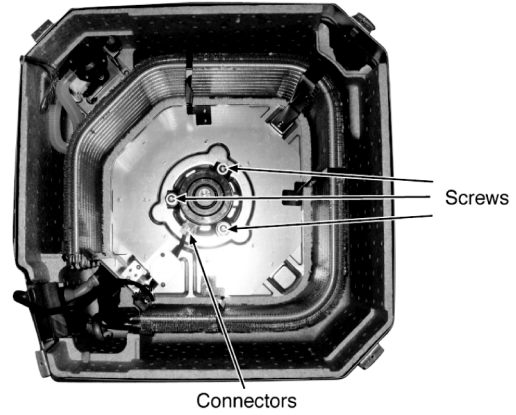

Fig. 8

## 12.5. Outdoor Unit



### WARNING

High voltages are generated in the electrical parts area by the capacitor. Ensure that the capacitor has discharged sufficiently before proceeding with repair work. Failure to heed this caution may result in electric shocks.

### 12.5.1. Removing the Cabinet Top Plate and Cabinet Front Plate

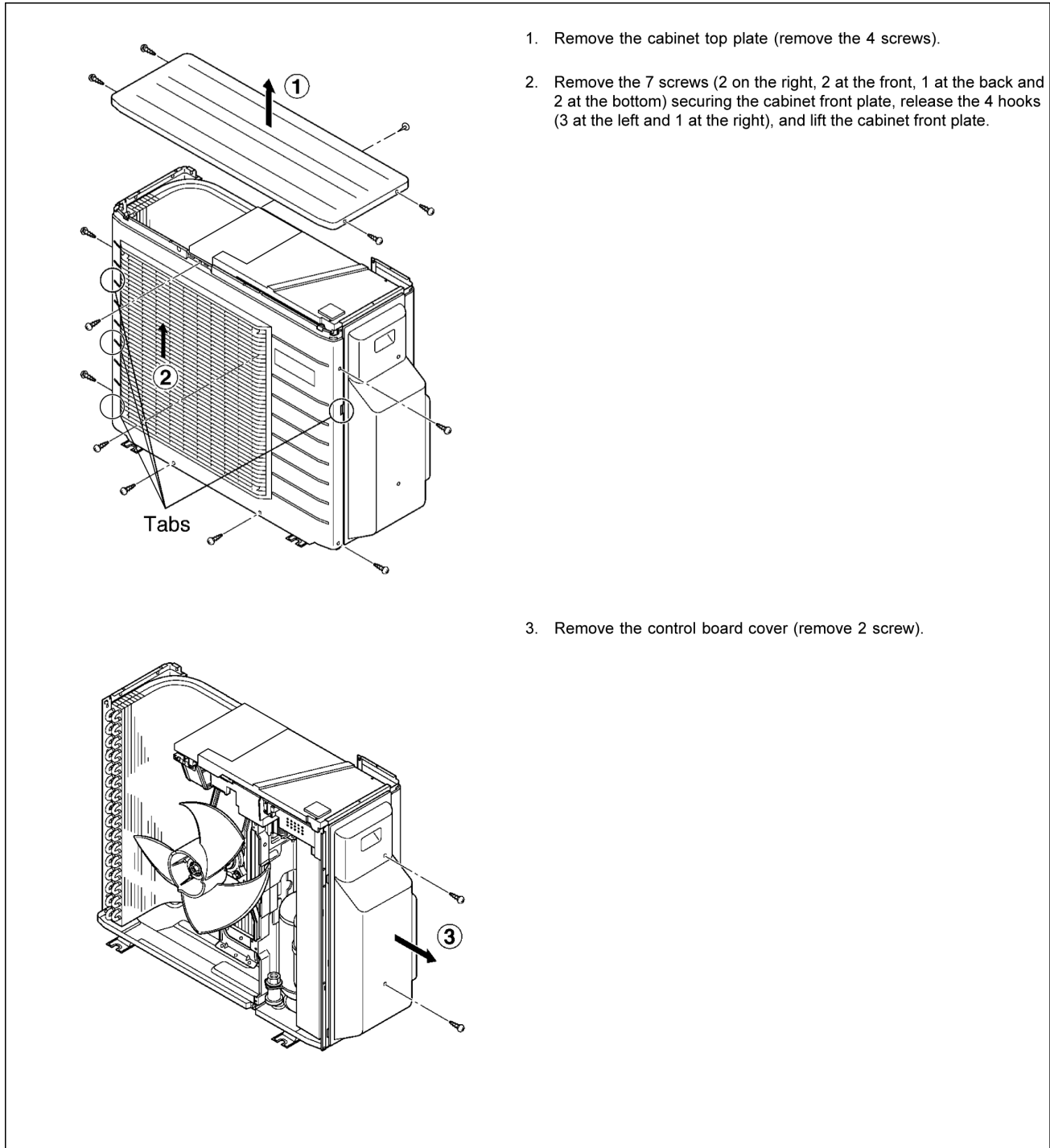

### 12.5.2. Removing the Control P.C. Board

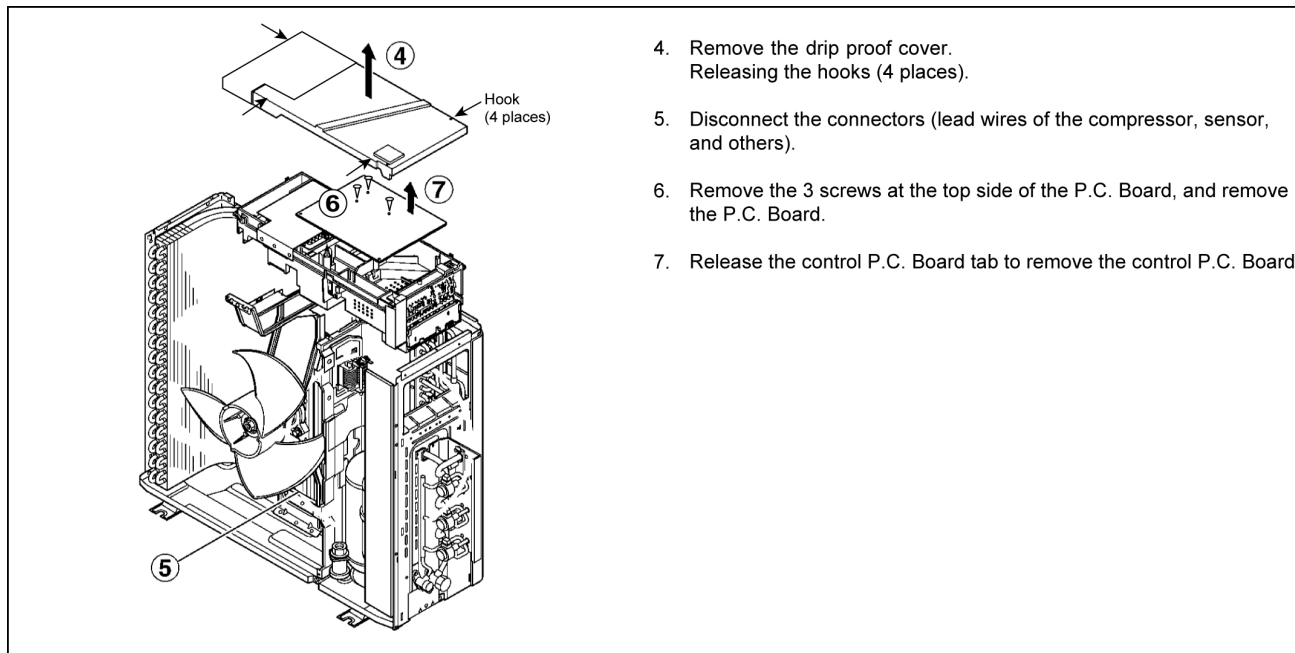

### 12.5.3. Removing the Propeller Fan and Fan Motor

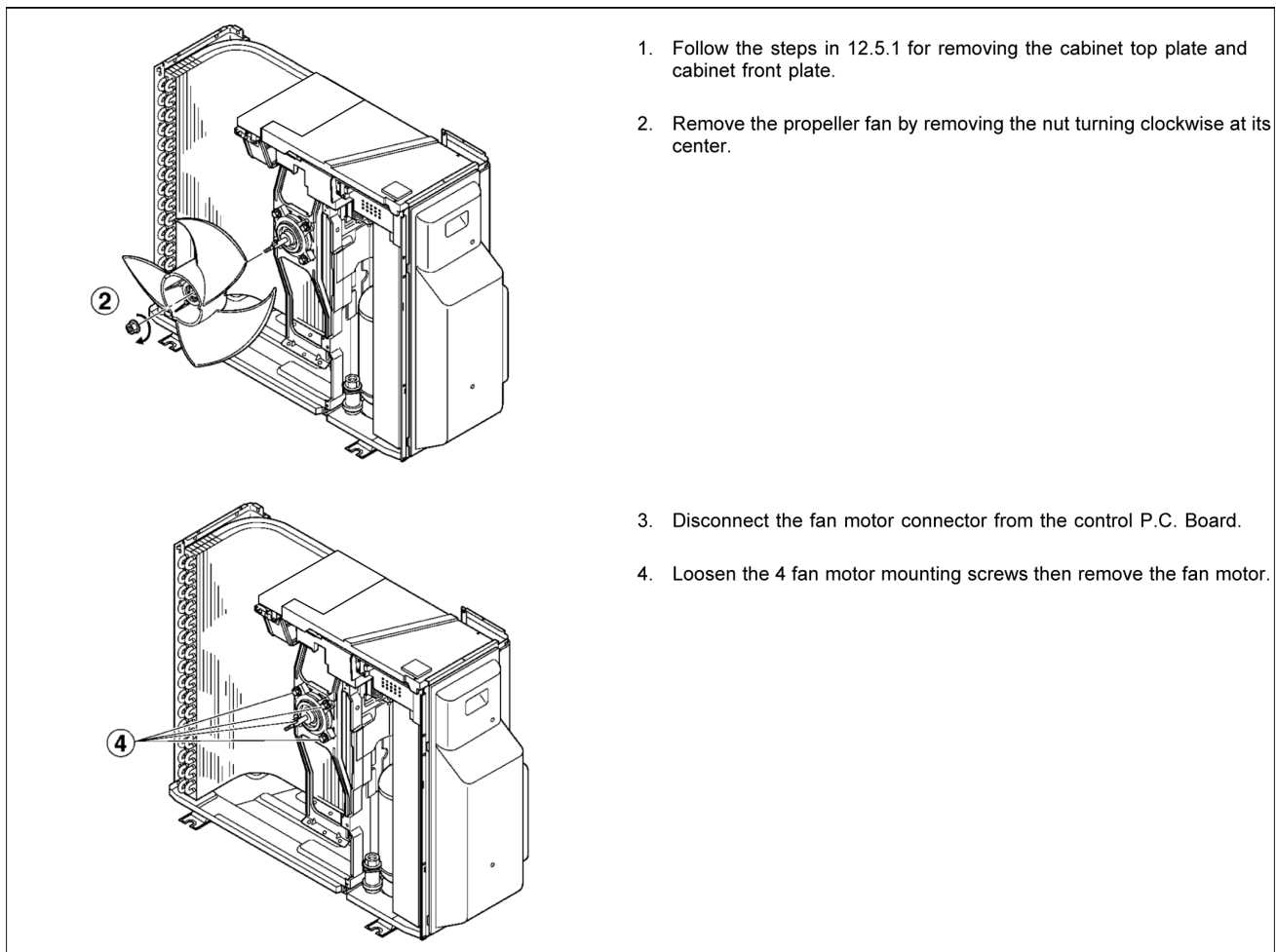

# 13 Technical Data

## 13.1. Operation Characteristics

CU-3E18EBE (one room operation)

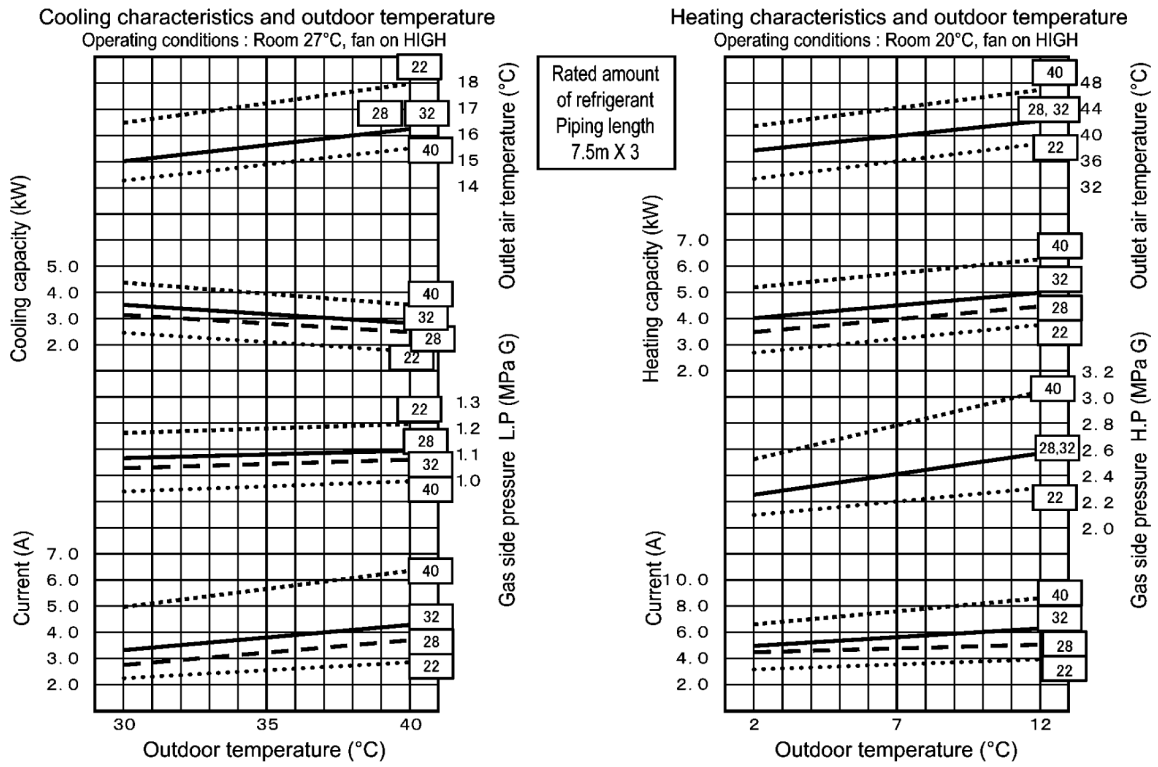

CU-3E18EBE (two rooms operation)

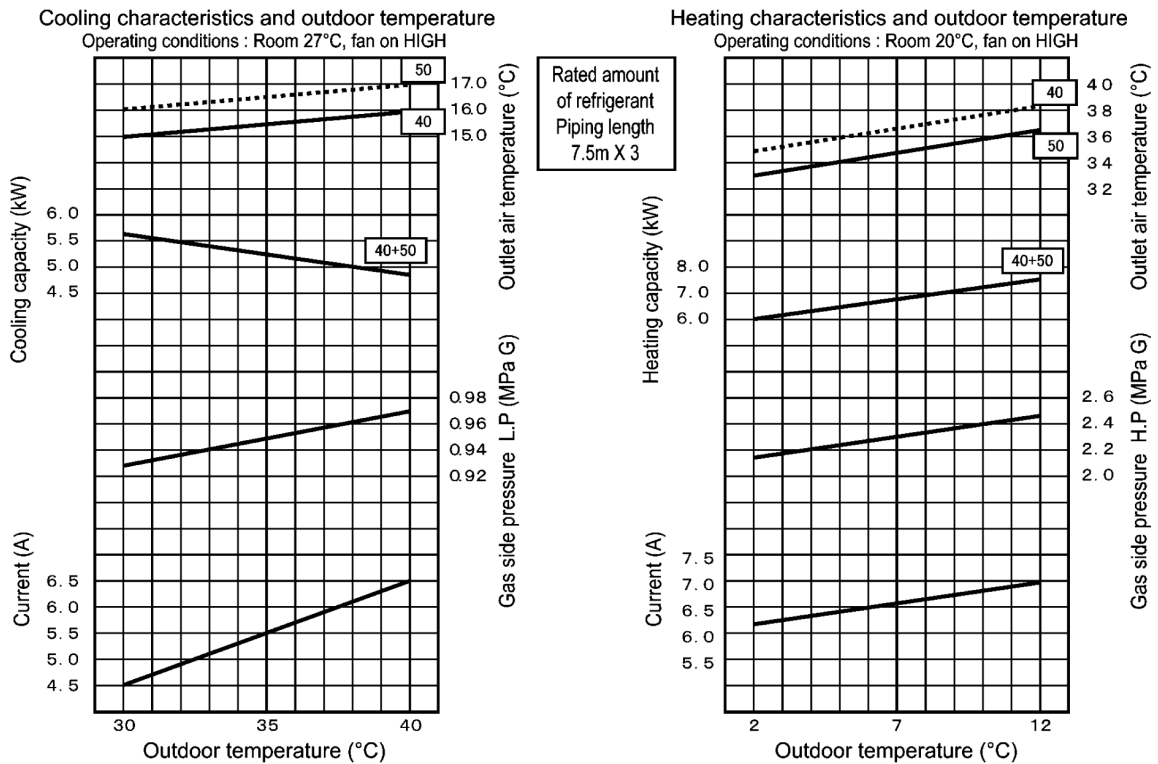

**CU-3E18EBE (three rooms operation)**

Cooling characteristics and outdoor temperature  
Operating conditions : Room 27°C, fan on HIGH

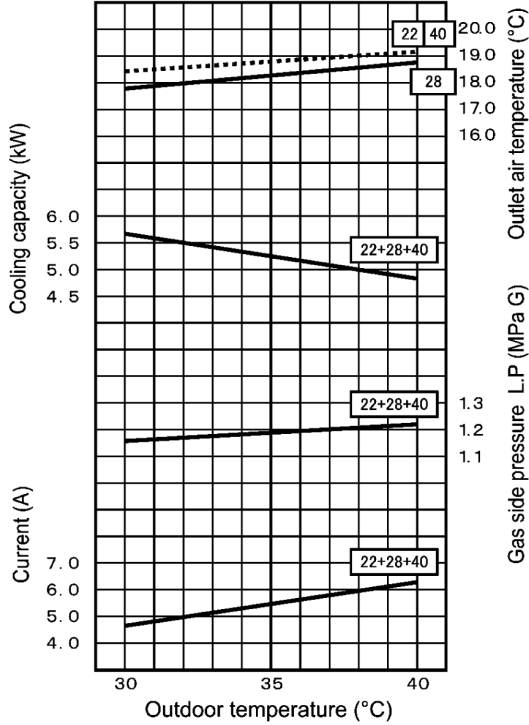

Heating characteristics and outdoor temperature  
Operating conditions : Room 20°C, fan on HIGH

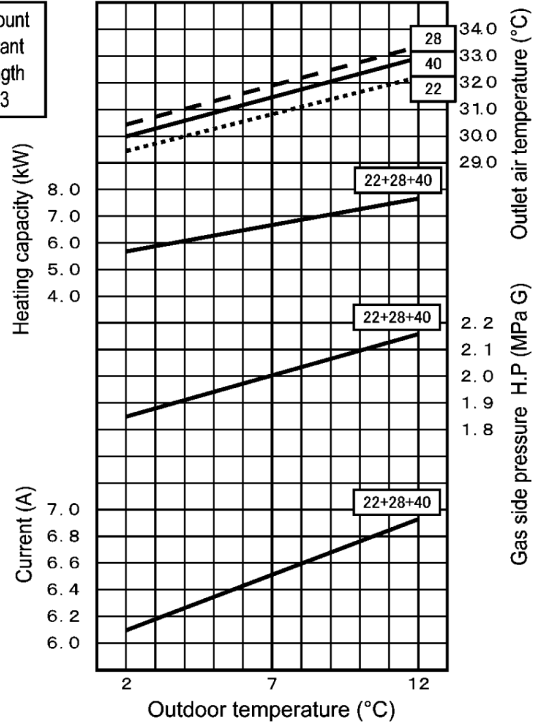

**CU-3E23CBPG (one room operation)**

Cooling characteristics and outdoor temperature  
Operating conditions\*: Room 27°C, fan on HIGH

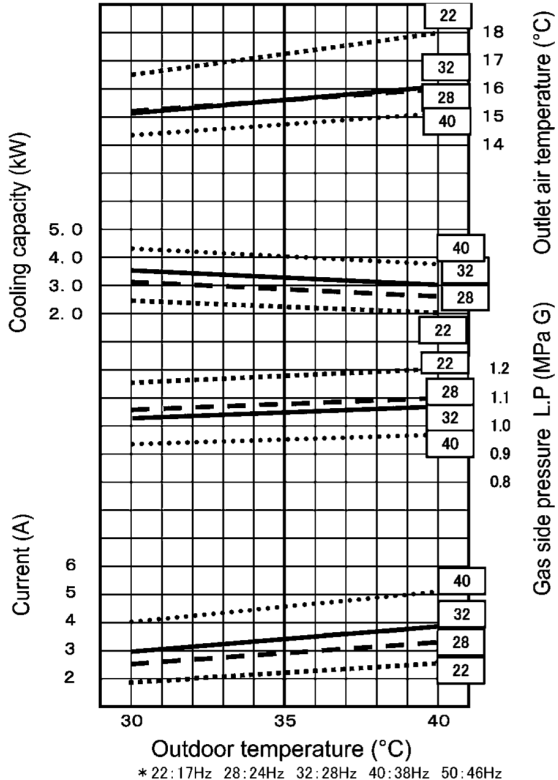

Heating characteristics and outdoor temperature  
Operating conditions\*: Room 20°C, fan on HIGH

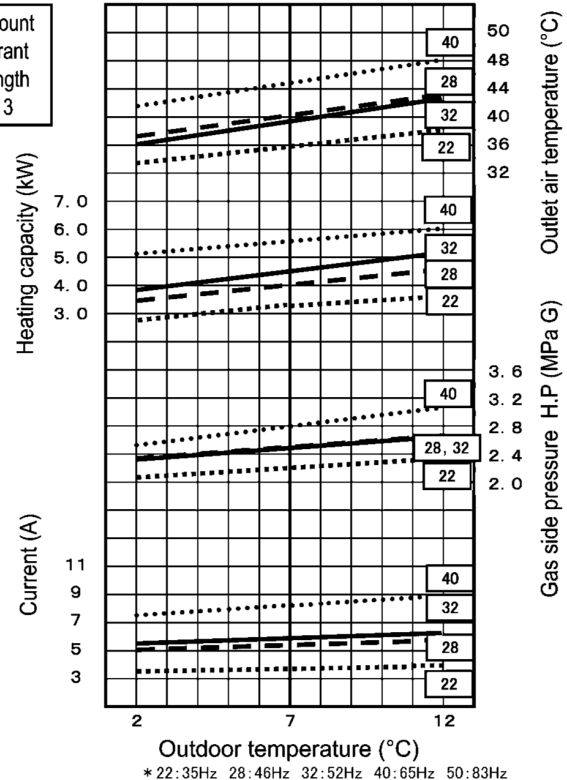

# 14 Exploded View and Replacement Parts List

## 14.1. Wall Type

### 14.1.1. Exploded View (Indoor Unit)

CS-ME7DKEG / CS-ME7DKDG / CS-E9DKEW / CS-E9DKDW / CS-E12DKEW / CS-E12DKDW

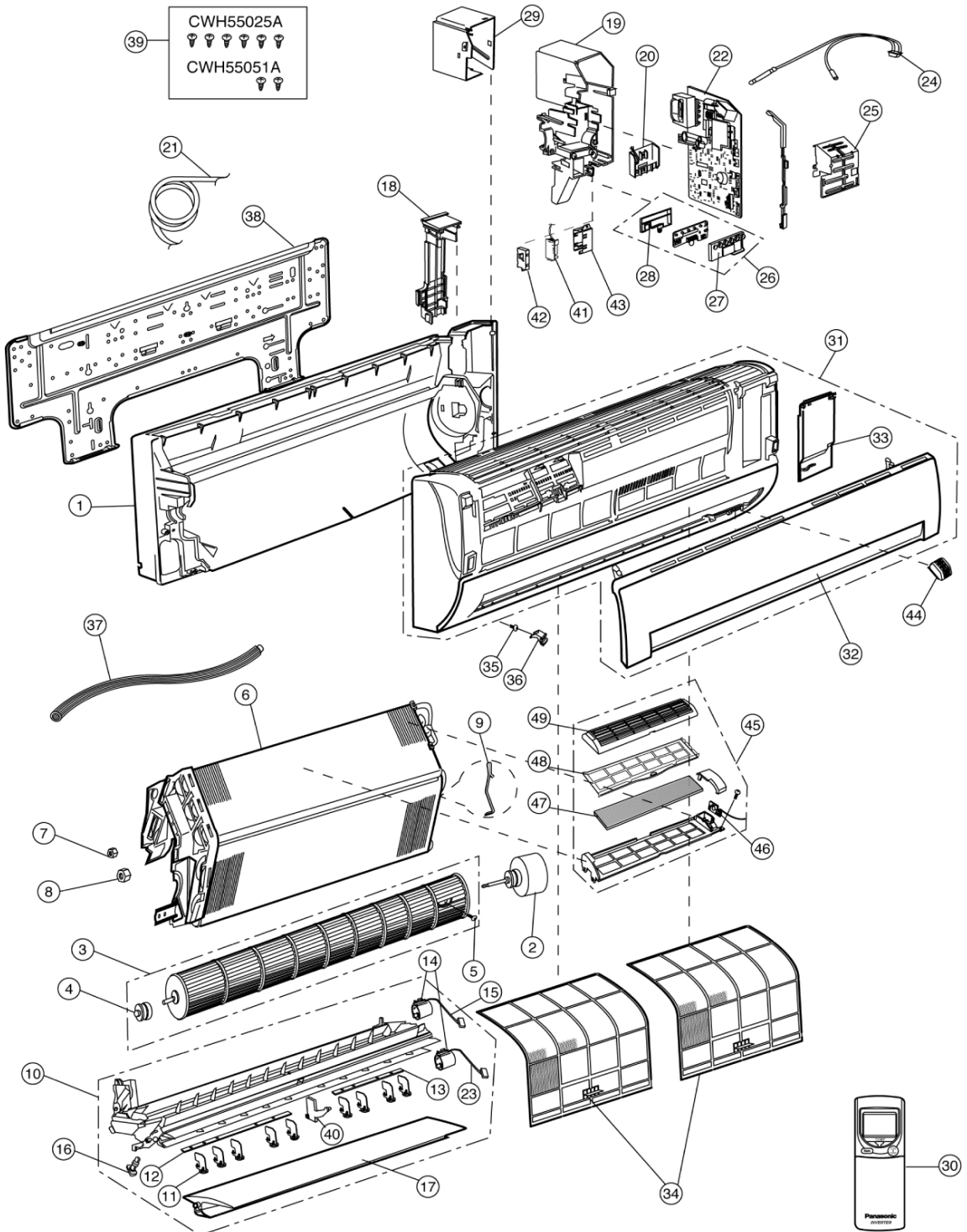

Note:

The above exploded view is for the purpose of parts disassembly and replacement.

The non-numbered parts are not kept as standard service parts.

## 14.1.2. Replacement Parts List (Indoor Unit)

### Models:

CS-ME7DKEG / CS-ME7DKDG /

CS-E9DKEW / CS-E9DKDW /

CS-E12DKEW / CS-E12DKDW

REF. NO.	PART NAME & DESCRIPTION	QTY.	CS-ME7DKEG CS-ME7DKDG	CS-E9DKEW CS-E9DKDW	CS-E12DKEW CS-E12DKDW	REMARKS
1	CHASSY COMPLETE	1	CWD50C1431	←	←	
2	FAN MOTOR	1	CWA981149	←	←	●
3	CROSS FLOW FAN COMPLETE	1	CWH02C1031	←	←	
4	BEARING ASS'Y	1	CWH64K007	←	←	
5	SCREW - CROSS FLOW FAN	1	CWH4580304	←	←	
6	EVAPORATOR	1	CWB30C1597	←	CWB30C1726	
7	FLARE NUT	1	CWT25086 (1/4")	←	←	
8	FLARE NUT	1	CWT25087 (3/8")	←	CWT25096 (1/2")	
9	HOLDER SENSOR	1	CWH32143	←	←	
10	DISCHARGE GRILLE COMPLETE	1	CWE20C2343	←	←	
11	VERTICAL VANE	9	CWE241150	←	←	
12	CONNECTING BAR	1	CWE261072	←	←	
13	CONNECTING BAR	1	CWE261065	←	←	
14	AIR SWING MOTOR	1	CWA98260	←	←	●
15	LEAD WIRE - AIR SWING MOTOR	1	CWA67C3849	←	←	
16	CAP - DRAIN TRAY	1	CWH521096	←	←	
17	HORIZONTAL VANE	1	CWE241173	←	←	
18	BACK COVER CHASSIS	1	CWD932454	←	←	
19	CONTROL BOARD CASING	1	CWH102259	←	←	
20	TERMINAL BOARD COMPLETE	1	CWA28C2082	←	←	●
21	POWER SUPPLY CORD	1	-	←	-	
22	ELECTRONIC CONTROLLER - MAIN	1	CWA73C1679	CWA73C1667	CWA73C1668	●
23	LEAD WIRE - AIR SWING MOTOR	1	CWA67C3977	←	←	●
24	SENSOR COMPLETE	1	CWA50C2122	←	←	●
25	CONTROL BOARD FRONT COVER	1	CWH13C1120	←	←	
26	INDICATOR COMPLETE	1	CWE39C1126	←	←	●
27	INDICATOR HOLDER	1	CWD932429	←	←	
28	INDICATOR HOLDER	1	CWD932430	←	←	
29	CONTOL BOARD TOP COVER	1	CWH131207	←	←	
30	REMOTE CONTROL COMPLETE	1	CWA75C2616	←	←	●
31	FRONT GRILLE COMPLETE	1	CWE11C3138	←	←	●
32	INTAKE GRILLE	1	CWE22C1154	←	←	
33	GRILLE DOOR	1	CWE141073	←	←	
34	AIR FILTER	2	CWD001144	←	←	
35	SCREW - FRONT GRILLE	2	XTT4+16C	←	←	
36	CAP - FRONT GRILLE	2	CWH521109	←	←	
37	DRAIN HOSE	1	CWH851063	←	←	
38	INSTALLATION PLATE	1	CWH361067	←	←	
39	BAG COMPLETE - INSTALLATION SCREW	1	CWH82C067	←	←	
40	FULCRUM	1	CWH621046	←	←	
41	ELECTRONIC CONTROLLER - IONIZER	1	CWA743675	←	←	●
42	CASING - IONIZER	1	CWD932464	←	←	
43	CASING - IONIZER	1	CWD932431	←	←	
44	ION GENERATOR	1	CWH94C0001	←	←	
45	SUPERSONIC AIR PURIFYING DEVICE	1	CWH91C1013	←	←	
46	ELECTRONIC CONTROLLER SUPERSONIC	1	CWA743874	←	←	●
47	SUPERSONIC ALLERU BUSTER FILTER	1	CWD00C1133	←	←	
48	FRAME FR AIR FILTER SUPERSONIC	1	CWD011026	←	←	
49	FRAME FR AIR FILTER SUPERSONIC	1	CWD011027	←	←	

(Note)

- All parts are compliant with EU RoHS legislation.
- All parts are supplied from PHAAM, Malaysia (Vendor Code: 061).
- "●" marked parts are recommended to be kept in stock.

### 14.1.3. Exploded View (Indoor Unit)

#### CS-E15DKEW / CS-E15DKDW

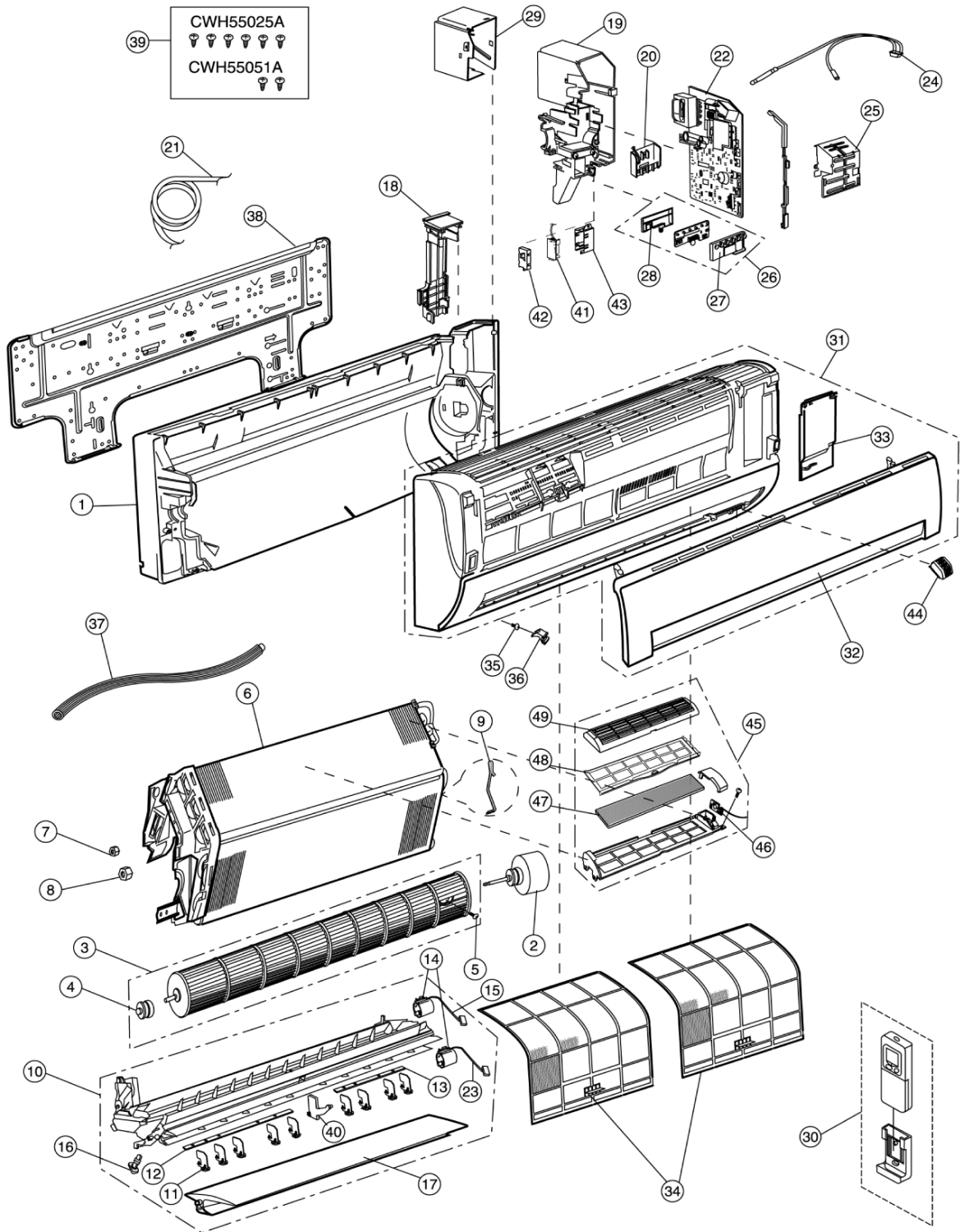

Note:

The above exploded view is for the purpose of parts disassembly and replacement.  
The non-numbered parts are not kept as standard service parts.

## 14.1.4. Replacement Parts List (Indoor Unit)

Models:

CS-E15DKEW / CS-E15DKDW

REF. NO.	PART NAME & DESCRIPTION	QTY.	CS-E15DKEW	CS-E15DKDW	REMARKS
1	CHASSY COMPLETE	1	CWD50C1431	←	
2	FAN MOTOR	1	CWA981149J	←	●
3	CROSS FOLW FAN COMPLETE	1	CWH02C1031	←	
4	BEARING ASS'Y	1	CWH64K007	←	
5	SCREW - CROSS FLOW FAN	1	CWH4580304	←	
6	EVAPORATOR	1	CWB30C1726	←	
7	FLARE NUT	1	CWT251030 (1/4")	←	
8	FLARE NUT	1	CWT251032 (1/2")	←	
9	HOLDER SENSOR	1	CWH32143	←	
10	DISCHARGE GRILLE COMPLETE	1	CWE20C2343	←	
11	VERTICAL VANE	9	CWE241150	←	
12	CONNECTING BAR	1	CWE261072	←	
13	CONNECTING BAR	1	CWE261065	←	
14	AIR SWING MOTOR	2	CWA98260+MJ	←	●
15	LEAD WIRE - AIR SWING MOTOR	1	CWA67C3849	←	
16	CAP - DRAIN TRAY	1	CWH521096	←	
17	HORIZONTAL VANE	1	CWE241173	←	
18	BACK COVER CHASSIS	1	CWD932454	←	
19	CONTROL BOARD CASING	1	CWH102259	←	
20	TERMINAL BOARD COMPLETE	1	CWA28C2082J	←	●
21	POWER SUPPLY CORD	1	-	←	
22	ELECTRONIC CONTROLLER - MAIN	1	CWA73C1669	←	●
23	LEAD WIRE - AIR SWING MOTOR	1	CWA67C3977	←	●
24	SENSOR COMPLETE	1	CWA50C2122	←	●
25	CONTROL BOARD FRONT COVER	1	CWH13C1120	←	
26	INDICATOR COMPLETE	1	CWE39C1126-1	←	●
27	INDICATOR HOLDER	1	CWD932429	←	
28	INDICATOR HOLDER	1	CWD932430	←	
29	CONTROL BOARD TOP COVER	1	CWH131207	←	
30	REMOTE CONTROL COMPLETE	1	CWA75C2616	←	●
31	FRONT GRILLE COMPLETE	1	CWE11C3138	←	●
32	INTAKE GRILLE	1	CWE22C1154	←	
33	GRILLE DOOR	1	CWE141073	←	
34	AIR FILTER	2	CWD001144	←	
35	SCREW - FRONT GRILLE	2	XTT4+16CFJ	←	
36	CAP - FRONT GRILLE	2	CWH521109	←	
37	DRAIN HOSE	1	CWH851063	←	
38	INSTALLATION PLATE	1	CWH361067	←	
39	BAG COMPLETE - INSTALLATION SCREW	1	CWH82C067	←	
40	FULCRUM	1	CWH621046	←	
41	ELECTRONIC CONTROLLER - IONIZER	1	CWA743675	←	●
42	CASING - IONIZER	1	CWD932464	←	
43	CASING - IONIZER	1	CWD932431	←	
44	ION GENERATOR	1	CWH94C0001	←	
45	SUPERSONIC AIR PURIFYING DEVICE	1	CWH91C1013	←	
46	ELECTRONIC CONTROLLER SUPERSONIC	1	CWA743874	←	●
47	SUPER ALLERU BUSTER FILTER	1	CWD00C1133	←	
48	FRAME FR AIR FILTER SUPERSONIC	1	CWD011026	←	
49	RFRAME FR AIR FILTER SUPERSONIC	1	CWD011027	←	

(Note)

- All parts are compliant with EU RoHS legislation.
- All parts are supplied from PHAAM, Malaysia (Vendor Code: 061).
- “●” marked parts are recommended to be kept in stock.

### 14.1.5. Exploded View (Indoor Unit)

CS-E18DKEW / CS-E18DKDW

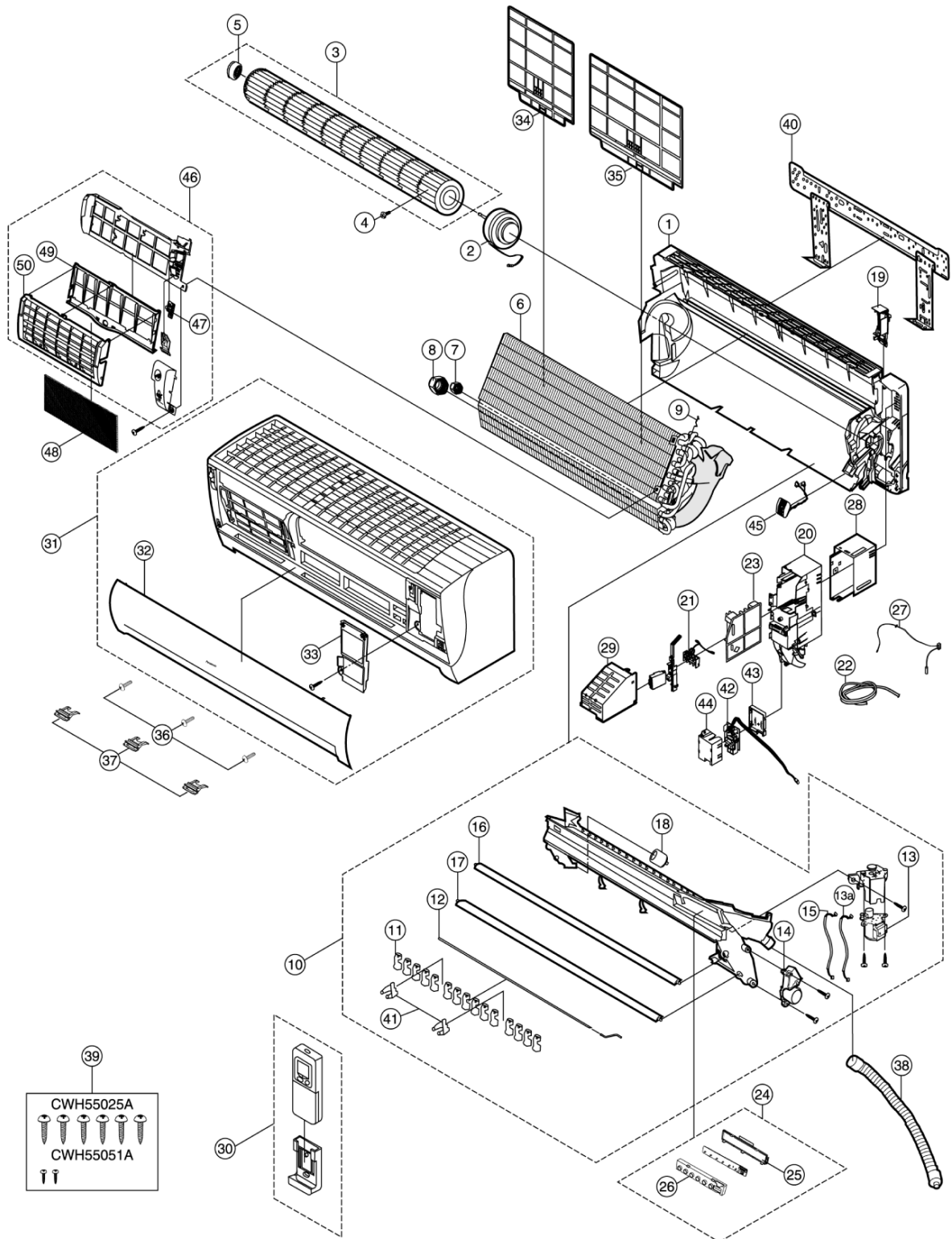

## 14.1.6. Replacement Parts List (Indoor Unit)

Models:

CS-E18DKEW / CS-E18DKDW

REF. NO.	PART NAME & DESCRIPTION	QTY.	CS-E18DKEW	CS-E18DKDW	REMARKS
1	CHASSY COMPLETE	1	CWD50C1382	←	
2	FAN MOTOR	1	CWA981149J	←	●
3	CROSS FLOW FAN COMPLETE	1	CWH02C1010	←	
4	SCREW - CROSS FLOW FAN	1	CWH551146	←	
5	BEARING ASS'Y	1	CWH64K007	←	
6	EVAPORATOR	1	CWB30C1533	←	
7	FLARE NUT	1	CWT251030 (1/4")	←	
8	FLARE NUT	1	CWT251032 (1/2")	←	
9	HOLDER SENSOR	1	CWH32143	←	
10	DISCHARGE GRILLE COMPLETE	1	CWE20C2441	←	
11	VERTICAL VANE	15	CWE241088	←	
12	CONNECTING BAR	1	CWE261025	←	
13	AIR SWING MOTOR	1	CWA98260+MJ	←	●
13a	LEAD WIRE - AIR SWING MOTOR	1	CWA67C3849	←	
14	AIR SWING MOTOR	1	CWA98K1008	←	●
15	LEAD WIRE - AIR SWING MOTOR	1	CWA67C3731	←	
16	HORIZONTAL VANE	1	CWE241152A	←	
17	HORIZONTAL VANE	1	CWE241153A	←	
18	CAP - DRAIN TRAY	1	CWH52C1001	←	
19	BACK COVER CHASSIS	1	CWD932162B	←	
20	CONTROL BOARD CASING	1	CWH102250	←	
21	TERMINAL BOARD COMPLETE	1	CWA28C2082J	←	●
22	POWER SUPPLY CORD	1	—	←	●
23	ELECTRONIC CONTROLLER - MAIN	1	CWA73C1670	←	●
24	INDICATOR COMPLETE	1	CWE39C1116	←	●
25	INDICATOR HOLDER	1	CWD932435	←	
26	INDICATOR HOLDER	1	CWD932436	←	
27	SENSOR COMPLETE	1	CWA50C2122	←	●
28	CONTROL BOARD TOP COVER	1	CWH131209	←	
29	CONTROL BOARD FRONT COVER	1	CWH131210	←	
30	REMOTE CONTROL COMPLETE	1	CWA75C2616	←	●
31	FRONT GRILLE COMPLETE	1	CWE11C3160	←	●
32	INTAKE GRILLE COMPLETE	1	CWE22C1159	←	●
33	GRILLE DOOR	1	CWE141076	←	
34	AIR FILTER (L)	1	CWD001137	←	
35	AIR FILTER (R)	1	CWD001138	←	
36	SCREW - FRONT GRILLE	3	XTT4+16CFJ	←	
37	CAP - FRONT GRILLE	3	CWH521062A	←	
38	DRAIN HOSE	1	CWH851063	←	
39	BAG COMPLETE - INSTALLATION SCREW	1	CWH82C067	←	
40	INSTALLATION PLATE	1	CWH36K1007	←	
41	FULCRUM	2	CWH621047	←	
42	ELECTRONIC CONTROLLER - IONIZER	1	CWA743675	←	●
43	CASING - IONIZER	1	CWD932464	←	
44	CASING - IONIZER	1	CWD932527	←	
45	ION GENERATOR	1	CWH94C0001	←	
46	SUPERSONIC AIR PURIFYING DEVICE	1	CWH91C1013	←	
47	ELECTRONIC CONTROLLER SUPERSONIC	1	CWA743874	←	●
48	SUPER ALLERU BUSTER FILTER	1	CWD00C1133	←	
49	FRAME FR AIR FILTER SUPERSONIC	1	CWD011026	←	
50	RRAME FR AIR FILTER SUPERSONIC	1	CWD011027	←	

(Note)

- All parts are compliant with EU RoHS legislation.
- All parts are supplied from PHAAM, Malaysia (Vendor Code: 061).
- “●” marked parts are recommended to be kept in stock.

## 14.2. Duct Type

### 14.2.1. Exploded View (Indoor Unit)

CS-ME10DD3EG / CS-E15DD3EW / CS-E18DD3EW

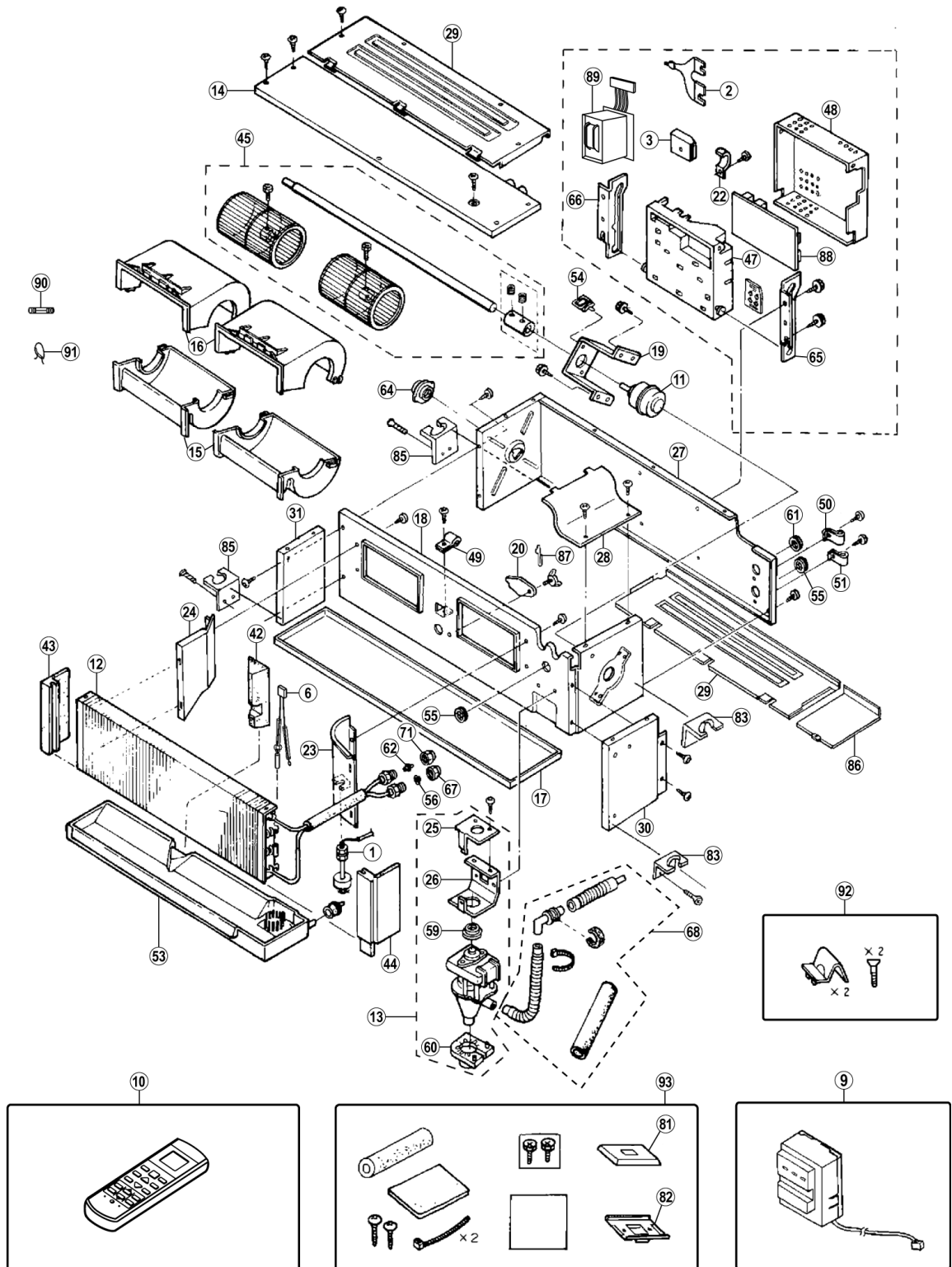

Note:

The above exploded view is for the purpose of parts disassembly and replacement.  
The non-numbered parts are not kept as standard service parts.

## 14.2.2. Replacement Parts List (Indoor Unit)

Models:

CS-ME10DD3EG / CS-E15DD3EW / CS-E18DD3EW

REF NO.	PART NAME & DESCRIPTION	QTY.	CS-ME10DD3EG	CS-E15DD3EW	CS-E18DD3EW	REMARKS
1	FLOAT SWITCH	1	CWA12161	←	←	●
2	THERMAL FUSE	1	CWA16C1038	←	←	●
3	TERMINAL BOARD COMPLETE	1	CWA28K1045J	←	←	●
6	SENSOR COMPLETE	1	CWA50C2270	←	←	●
9	REMOTE CONTROL (RECEIVER)	1	CWA75C2773	←	←	●
10	REMOTE CONTROL	1	CWA75C2610X	←	←	●
11	FAN MOTOR	1	ARW41G8P30AC	←	←	●
12	EVAPORATOR	1	CWB302123XA	CWB302123XB	CWB302356X	
13	DRAIN PUMP COMPLETE	1	CWB53C1010	←	←	●
14	PARTICULAR PLATE-1	1	CWD11024XA	←	CWD11026XA	
15	AIR GUIDER-1	2	CWD32091	←	←	
16	AIR GUIDER-2	2	CWD32092	←	←	
17	BOTTOM PLATE	1	CWD52259X	←	←	
18	BULKHEAD	1	CWD531019	←	←	
19	BRACKET FAN MOTOR	1	CWD541036	←	←	
20	PARTICULAR PLATE-2	1	CWD74100	←	←	
22	HOLDER LEAD WIRE-1	1	CWH31103	←	←	
23	PARTICULAR PLATE-3	1	CWD90K080	←	CWD90K086	
24	PARTICULAR PLATE-4	1	CWD90616	←	CWD90635	
25	PARTICULAR PLATE-5	1	CWD90618	←	←	
26	PARTICULAR PLATE-6	1	CWD90766	←	←	
27	CABINET BACK PLATE	1	CWE02079	←	←	
28	CABINET TOP PLATE-1	1	CWE03034	←	←	
29	CABINET TOP PLATE-2	2	CWE03035X	←	←	
30	CABINET SIDE PLATE-1	1	CWE04071	←	CWE04079	
31	CABINET SIDE PLATE-2	1	CWE04072X	←	CWE04080X	
42	INSULATION SHEET-1	1	CWG07165	←	CWG07174	
43	INSULATION SHEET-2	1	CWG07166	←	CWG07175	
44	INSULATION SHEET-3	1	CWG07167	←	CWG07176	
45	CROSS-FLOW FAN COMPLETE	1	CWH01C005	←	←	
47	CONTROL BOARD BOX	1	CWH10527	←	←	
48	CONTROL COVER	1	CWH131144X	←	←	
49	HOLDER LEAD WIRE-2	1	CWH31044	←	←	
50	HOLDER LEAD WIRE-3	1	CWH31030	←	←	
51	HOLDER LEAD WIRE-4	1	CWD77013	←	←	
53	DRAIN TRAY	1	CWH40C061	←	←	
54	BELT	1	CWH4605008	←	←	
55	BUSHING-1	2	CWH4610440	←	←	
56	CAP-1 (1/4" LIQUID SIDE)	1	CWH52061	←	←	
59	BUSHING-2	1	CWH50147	←	←	
60	BUSHING-3	1	CWH50146	←	←	
61	BUSHING-4	1	CWH51134	←	←	
62	CAP-2 (GAS SIDE)	1	CWH52062 (3/8")	CWH52063 (1/2")	←	
64	FULCRUM	1	CWH64C015	←	←	
65	GUIDER-1	1	CWH691004	←	←	
66	GUIDER-2	1	CWH69025	←	←	
67	FLARE NUT (1/4")	1	CWT25086	←	←	
68	DRAIN HOSE COMPLETE	1	CWH85C008	←	←	
71	FLARE NUT (GAS SIDE)	1	CWT25087 (3/8")	CWT25096 (1/2")	←	
81	COVER FOR RECEIVER	1	CWD66132B	←	←	
82	RECEIVER PIECE-1	1	CWD90650	←	←	
83	PARTICULAR PIECE-1	2	CWD93435	←	←	
85	PARTICULAR PIECE-2	2	CWD93436	←	←	
86	CABINET BOTTOM PLATE	1	CWE05012X	←	←	
87	HOLDER SENSOR-2	1	CWH32137	←	←	
88	PC BOARD (MAIN)	1	CWA73C1840	CWA73C1841	CWA73C1842	●
89	TRASFORMER (ON-BOARD)	1	CWA40C1027	←	←	
90	FUSE (250V 3.15A)	1	XBA2C31TRO	←	←	
91	ZNR	1	ERZVEAV511	←	←	
92	BAG COMPLETE-1 (SCREWS, HOLDER)	1	CWG86C994	←	←	
93	BAG COMPLETE-2 (SCREWS, BELT, ETC.)	1	CWH82C1277	←	←	

(Note)

- All parts are compliant with EU RoHS legislation.
- All parts are supplied from ACD in Japan.
- “●” marked parts are recommended to be kept in stock.



## 14.3.2. Replacement Parts List (Indoor Unit)

### Models:

CS-ME10DTEG / CS-E15DTEW / CS-E18DTEW

REF NO.	PART NAME & DESCRIPTION	QTY.	CS-ME10DTEG	CS-E15DTEW	CS-E18DTEW	REMARKS
1	CHASSY COMPLETE	1	CWD50C1419	←	←	
2	FAN MOTOR	1	CWA921158J	←	←	●
3	SUPPORTER FAN MOTOR	2	CWD932270	←	←	
4	BLOWER WHEEL ASS'Y	2	CWH01K1014	←	←	
5	AIR GUIDER B.W.	2	CWD321046	←	←	
6	CONTROL BOARD ASS'Y	1	CWH10K1055	←	←	
7	FLARE NUT (1/2")	1	CWT251032	←	←	
8	TERMINAL BOARD ASS'Y	1	CWA28K1036J	←	←	●
10	ELECTRONIC CONTROLLER	1	CWA73C1774	CWA73C1771	CWA73C1772	●
11	SENSOR ASS'Y COMP.	1	CWA50C2157	←	←	●
12	LEAD WIRE FAN MOTOR	1	CWA67C4431	←	←	
13	LEAD WIRE FAN MOTOR	1	CWA67C4474	←	←	
14	EVAPORATOR	1	CWB30C1975	CWB30C1663	CWB30C1661	
15	SUPPORTER TUBE ASS'Y	1	CWD932259	←	←	
16	FLARE NUT (1/4")	1	CWT251030	←	←	
17	DRAIN PAN COMPLETE	1	CWH40C1023	←	←	
18	TAP DRAIN TRAY	1	CWH401031	←	←	
19	DISCHARGE GRILLE COMPLETE	1	CWE20C2223	←	←	
20	DISCHARGE GRILLE	1	CWE201046	←	←	
21	VANE - AIR SWING	1	CWE241124	←	←	
22	CONNECTING BAR	2	CWE261052	←	←	
23	CONNECTING BAR	2	CWE261053	←	←	
24	VANE	14	CWE241126	←	←	●
25	AIR SWING MOTOR	1	CWA981085J	←	←	●
26	INDICATOR COMP.	1	CWE39C1128	←	←	
28	CONTROL BOARD CASING ASS'Y	1	CWH13K1015	←	←	
31	INTAKE GRILLE COMPLETE	1	CWE22C1185	←	←	
32	AIR FILTER	2	CWJ0HBXY000003	←	←	
33	REMOTE CONTROL COMPLETE	1	CWA75C2610	←	←	●
36	DRAIN HOSE	1	CWH85284	←	←	
37	INSTALLATION HOLDER	1	CWH361018	←	←	
38	ACCESSORY COMPLETE	1	CWH82C1286	←	←	
39	FULCRUM	3	CWH621030	←	←	
40	FRONT GRILLE COMPLETE	1	CWE11C3209	←	←	
41	STRING COMPLETE	1	CWH84C1006	←	←	

(Note)

- All parts are compliant with EU RoHS legislation.
- All parts are supplied from PHAAM, Malaysia (Vendor Code: 061).
- “●” marked parts are recommended to be kept in stock.

## 14.4. Mini-Cassette Type

### 14.4.1. Exploded View (Indoor Unit)

CS-E15DB4EW / CS-E18DB4EW

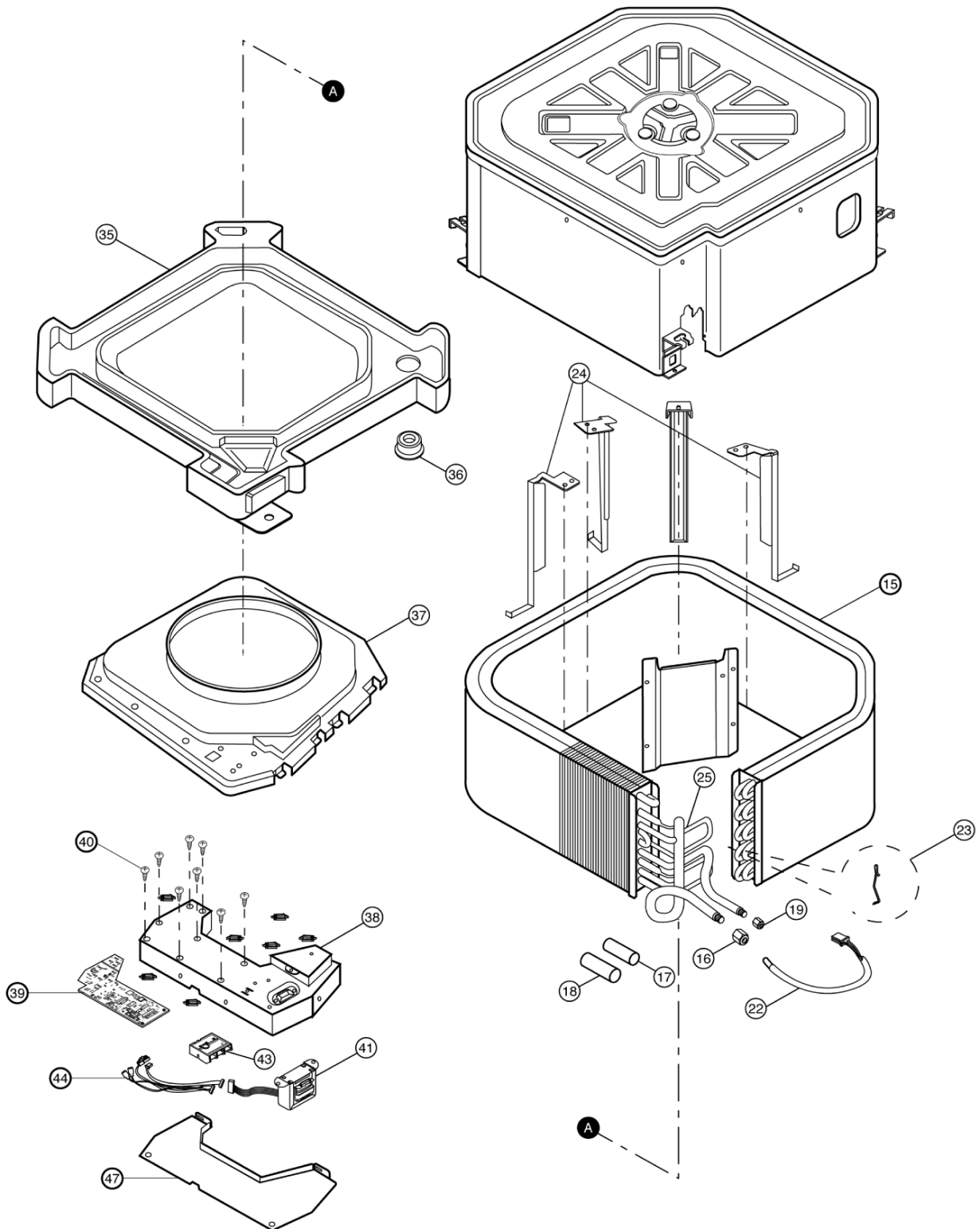

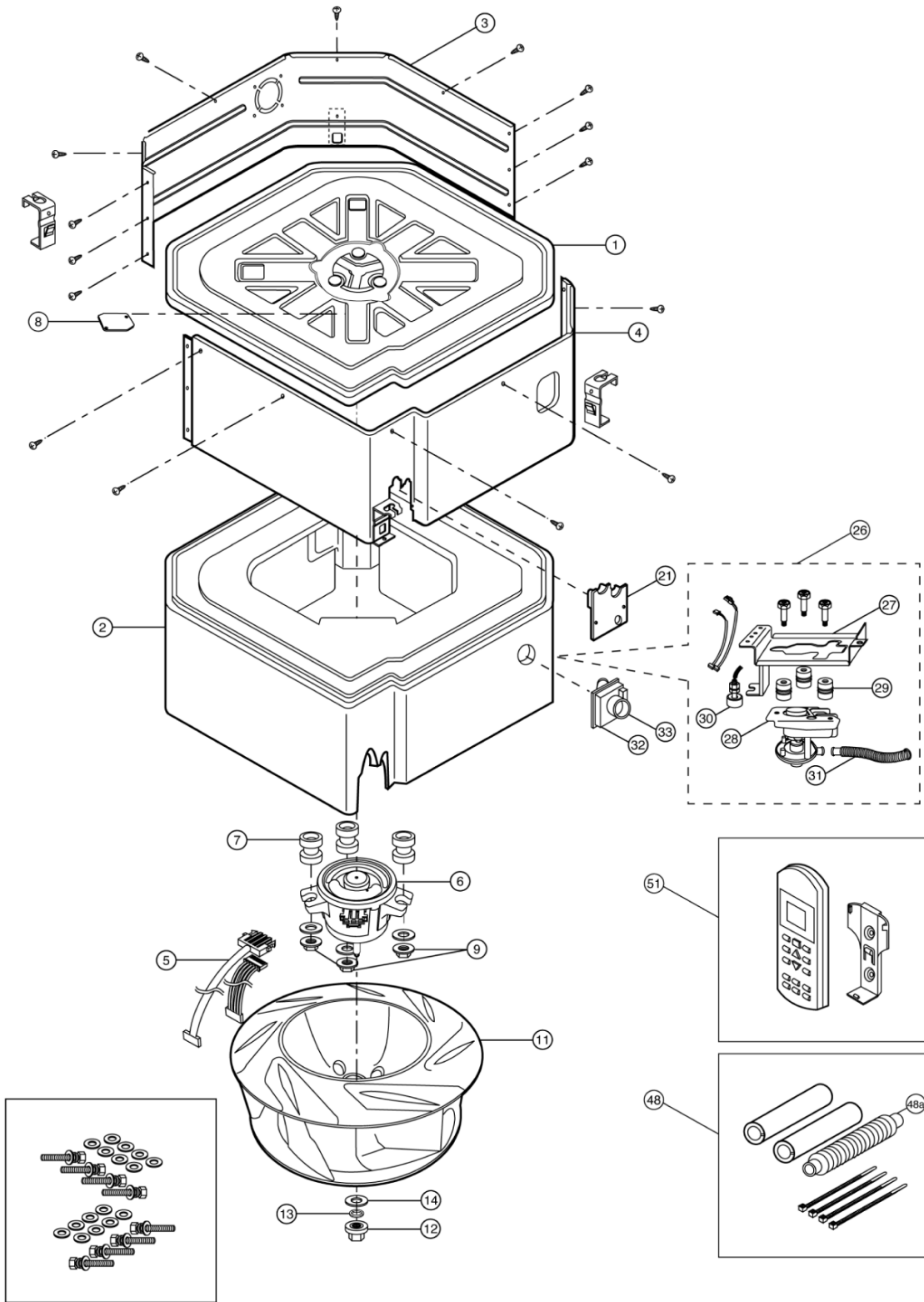

Note:

The above exploded view is for the purpose of parts disassembly and replacement.

The non-numbered parts are not kept as standard service parts.

## 14.4.2. Replacement Parts List (Indoor Unit)

Models:

CS-E15DB4EW / CS-E18DB4EW

REF NO.	PART NAME & DESCRIPTION	QTY.	CS-E15DB4EW	CS-E18DB4EW	REMARKS
1	BASE PAN ASS'Y	1	CWD52K1100	←	
2	INNER POLYSTYRENE COMPLETE	1	CWG07C1047	←	
3	CABINET SIDE PLATE ASS'Y	1	CWE041121	←	
4	CABINET SIDE PLATE ASS'Y	1	CWE041122	←	
5	LEAD WIRE - FAN MOTOR	1	CWA67C5136	←	
6	FAN MOTOR	1	EHDS50A40AC	←	●
7	ANTI-VIBRATION BUSHING	3	CWH501065	←	
8	CORD HOLDER	1	CWD741024	←	
9	SCREW - FAN MOTOR	3	CWH7080300J	←	
11	TURBO FAN	1	CWH03K1022	←	
12	NUT FOR TURBO FAN	1	CWH561042	←	
13	SP WASHER	1	XWA8BFJ	←	
14	WASHER	1	XWG8H22FJ	←	
15	EVAPORATOR COMPLETE	1	CWB30C1688	←	
16	FLARE NUT (1/2")	1	CWT251032	←	
17	HEATPROOF TUBE	1	CWG021024	←	
18	HEADPROOF TUBE	1	CWG021064	←	
19	FLARE NUT (1/4")	1	CWT251030	←	
21	PIPE COVER	1	CWD93C1050	←	
22	SENSOR - EVAPORATOR	1	CWA50C2274	←	
23	HOLD SENSOR	1	CWH32143	←	
24	EVAPORATOR SURPORTER	3	CWD911529A	←	
25	TUBE ASS'Y (CAPIL. TUBE)	1	CWT07K1188	←	
26	DRAIN PUMP COMPLETE	1	CWB53C1015	←	
27	PANEL DRAIN PUMP ASS'Y	1	CWD93K1008	←	
28	DRAIN PUMP	1	CWB532043J	←	
29	ANTI - VIBRATION BUSHING	3	CWH501080	←	
30	FLOAT SWITCH - DRAIN PUMP	1	CWA121215	←	
31	FLEXIBLE PIPE	1	CWH85C1033	←	
32	DRAIN NOZZLE	1	CWH411011	←	
33	DRAIN HOSE HEAT INSULATION	1	CWG321050	←	
35	DRAIN PAN - COMPLETE	1	CWH40C1034	←	
36	DRAIN PLUG	1	CWB821008	←	
37	AIR GUIDER BLOWER WHEEL	1	CWD321058	←	
38	CONTROL BOARD CASING	1	CWH10K1048	←	
39	ELECTRONIC CONTROLLER (MAIN)	1	CWA73C1778	CWA73C1779	●
40	SPACER	6	CWH541026	←	
41	TRANSFORMER	1	CWA40C1030	←	
43	TERMINAL BOARD - (3 PIN)	1	CWA28K1076J	←	●
44	LEAD WIRE - AIR TEMP. SENSOR	1	CWA67C5139	←	●
47	CONTROL BOARD COVER	1	CWH13C1100	←	
48	ACCESSORY COMPLETE	1	CWH82C127	←	
48A	HEATPROOF TUBE	1	CWG021025	←	
51	WIRELESS REMOTE CONTROL COMPLETE	1	CWA75C2610	←	●

(Note)

- All parts are compliant with EU RoHS legislation.
- All parts are supplied from PHAAM, Malaysia (Vendor Code: 061).
- “ ● ” marked parts are recommended to be kept in stock.

### 14.4.3. Exploded View (Indoor Unit Front Grille)

#### CZ-BT12DE (Front Grille Complete)

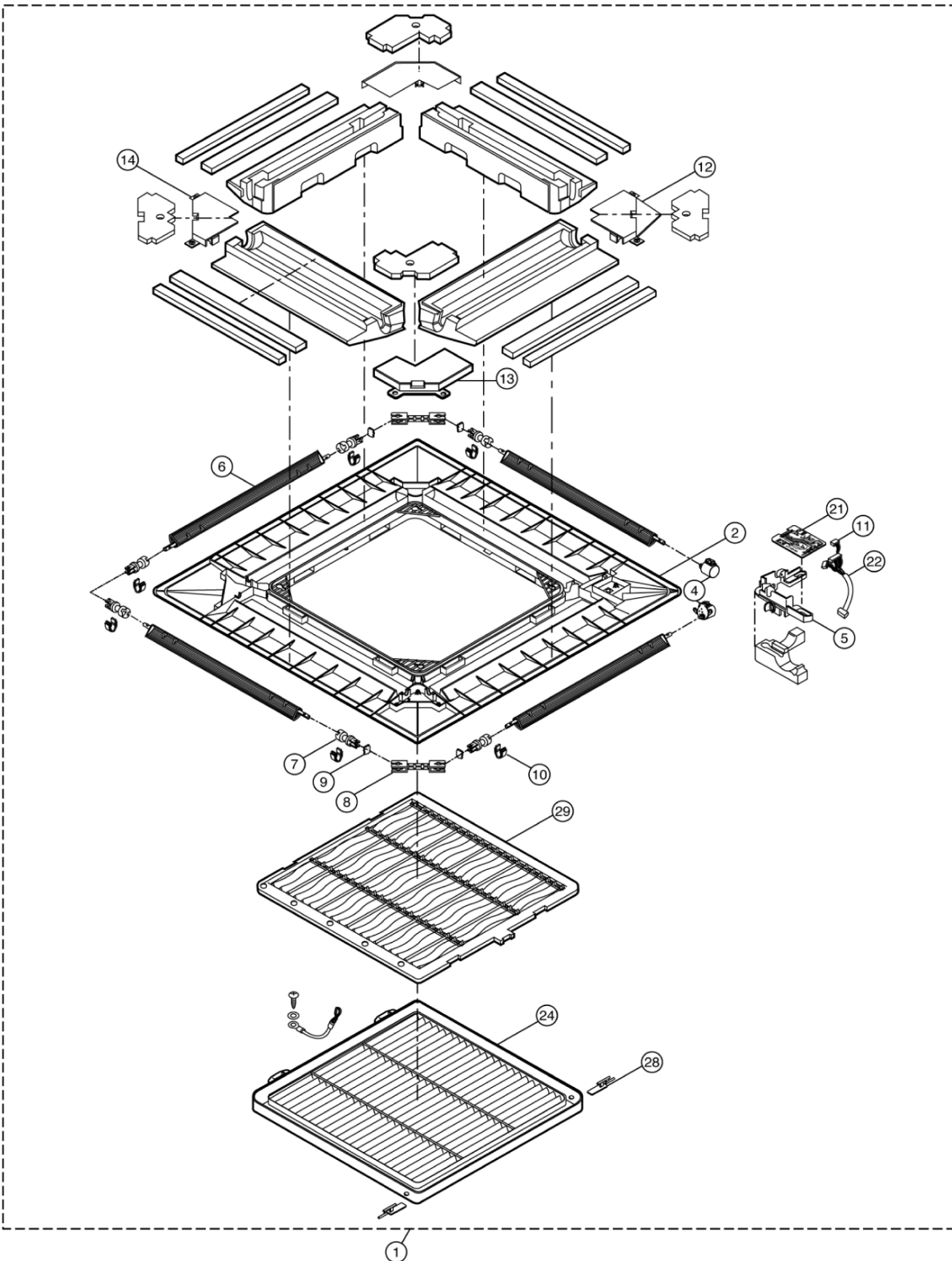

Note:

The above exploded view is for the purpose of parts disassembly and replacement.  
The non-numbered parts are not kept as standard service parts.

#### 14.4.4. Replacement Parts List (Indoor Unit Front Grille)

Model:

CZ-BT12DE (Front Grille Complete)

REF NO.	PART NAME & DESCRIPTION	QTY.	PART NO.	REMARKS
1	FRONT GRILLE - COMPLETE	1	CWE11C3105	
2	FRONE - FRONT GRILLE CO.	1	CWE11C3353	
4	A.S. MOTOR DC SINGLE 12V 250 OHM	2	CWA981105J	
5	BRACKET - A.S. MOTOR	1	CWD932522	
6	VANE	4	CWE241159	
7	SHAFT	6	CWH631038	
8	SHAFT	2	CWH631045	
9	CONNECTOR - SHAFT	4	CWH081007	
10	BEARING	6	CWH641008	
11	LEAD WIRE - A.S. MOTOR	1	CWA67C5117	
12	PLATE COVER FOR A.S. MOTOR	1	CWD911459	
13	PLATE COVER FOR CONNECTING SHAFT	2	CWD911460	
14	PLATE COVER FOR END SHAFT	1	CWD911461	
21	ELECTRONIC CONT. (RECEIVER & INDICATOR)	1	CWA743610	
22	LEAD WIRE - COMPLETE	1	CWA67C5576	
24	INTAKE GRILLE	1	CWE221131	
28	LEVER ARM	2	CWH651029	
29	AIR FILTER	1	CWD001142	

(Note)

- All parts are compliant with EU RoHS legislation.
- All parts are supplied from PHAAM, Malaysia (Vendor Code: 061).
- “●” marked parts are recommended to be kept in stock.



## 14.5.1. Replacement Parts List (Outdoor Unit)

Models:

CU-3E18EBE

REF NO.	PART NAME & DESCRIPTION	QTY.	CU-3E18EBE	REMARKS
A1	SWING COMPRESSOR	1	CW1684728	●
A2	VIBRATION ISOLATOR	3	CW128989J	
A3	NUT WITH WASHER	2	CW390214J	
A4	TERMINAL COVER	1	CW1262647	
A5	RUBBER BUSH, LEAD WIRE	1	CW0401393	
A6	RETAINER, OVER-LOAD RELAY	1	CW380620	
A8	SOUND INSULATION (SLEEVE)	1	CW1684735	
A9	SOUND INSULATION (INNER)	1	CW1684742	
A10	SOUND INSULATION (TOP)	1	CW1684759	
A13	SOUND INSULATION (MID TOP)	1	CW1684766	
B1	CROSS-FIN CONDENSER ASS'Y	1	CW1684773	
B1-1	DISTRIBUTOR	1	CW120410J	
B3-1	SET PLATE, STOP VALVE (1)	1	CW136410J	
B3-2	SET PLATE, STOP VALVE (2)	1	CW130699J	
B3-3-1	STOP VALVE ASS'Y (LIQUID LINE)	1	CW130584J	●
B3-3-2	BODY, MOTORIZED EXP. VALVE	3	CW1684780	
B3-3-3	SINGLE UNION JOINT	3	CW060321J	●
B3-3-4	STRAINER (FOR REF.)	3	CW131823J	
B3-3-5	STRAINER (FOR REF.)	1	CW008529J	
B3-3-6	PUTTY	3	CW130701J	
B3-3-7	FIXTURE, THERMISTOR	3	CW1303896	
B3-3-8	PUTTY	1	CW131313J	
B3-3-9	SOUNDPROOF PUTTY	1	CW165662J	
B3-4-1	STOP VALVE ASS'Y (GAS LINE)	1	CW1684797	●
B3-4-2	HALF UNION JOINT	3	CW257587J	
B3-4-3	FITTING SPRING, THERMISTOR	3	CW380120	
B3-5	FIXTURE, UNION JOINT	1	CW131314J	
B3-6	FIXTURE, UNION JOINT	1	CW131315J	
B3-7	RETAINER, UNION JOINT	1	CW380013J	
B3-8	RETAINER	1	CW380080J	
B4-1	BODY, FOUR WAY VALVE	1	CW1672857	●
B4-2-1	MUFFLER	1	CW1170298	
B6	FLARE NUT	3	CW119847J	
B7	FLARE NUT	3	CW008034J	
B9	BLIND CAP, FLARE NUT	3	CW1020920	
B10	BLIND CAP, FLARE NUT	3	CW1020937	
B12	CAP, STOP VALVE	1	CW045432J	
B13	CAP, STOP VALVE	1	CW007993J	
B14	SOUNDPROOF PUTTY	1	CW1666085	
B15	SOUND ABSORBING PUTTY	1	CW112853J	
B18	FITTING SPRING, THERMISTOR	1	CW380120	
B19	FIXTURE, THERMISTOR	1	CW1107384	
B22	SEALING MATERIAL (HEAT EXCH. TOP)	3	CW1684805	
C1	FAN BLADE ASS'Y	1	CW1684812	
C2	LOCK NUT, FAN BLADE	1	CW847002J	
C3	GUARD NET	1	CW118238J	
C4	AIR DISCHARGE GRILLE	1	CW163114J	
E1	BODY, SWITCH BOX	1	CW1684829	
E3	HEAT SINK ASS'Y	1	CW1684836	
E4	SWITCH BOX ASS'Y	1	CW1684843	
E4-1	SEALING MATERIAL	1	CW1684850	
E5	WIRE HARNESS ASS'Y	1	CW1684867	
E6	PRINTED CIRCUIT ASS'Y (CONTROL)	1	CW1684874	●
E6-1	FUSE	1	CW1684881	
E6-2	FUSE	2	CW153875J	
E7	PRINTED CIRCUIT ASS'Y (SERVICE)	1	CW1684898	●
E8	TERMINAL BLOCK ASS'Y	1	CW1684906	
E8-1	TERMINAL BLOCK	1	CW1684913	
E8-2	TERMINAL BLOCK	3	CW1684920	
E11	THERMISTOR ASS'Y (LIQUID)	1	CW130943J	●
E12	THERMISTOR ASS'Y (GAS)	1	CW1684937	●
E13	OVER LOAD RELAY	1	CW622423J	
E14	REACTOR	1	CW1684944	
E15	THERMISTOR ASS'Y	1	CW1684951	
E17	COIL ASS'Y, FOUR WAY VALVE	1	CW1684968	●
E17-1	COIL, FOUR WAY VALVE	1	CW148574J	●
E18	COIL ASS'Y, MOTORIZED EXP. VALVE	1	CW131335J	●
E18-1	COIL, MOTORIZED EXP. VALVE	1	CW130523J	●
E18-2	COIL, MOTORIZED EXP. VALVE	1	CW130524J	●

REF NO.	PART NAME & DESCRIPTION	QTY.	CU-3E18EBE	REMARKS
E18-3	COIL, MOTORIZED EXP. VALVE	1	CW130521J	●
E19	INSULATOR	1	CW137031J	
E20	DC FAN MOTOR ASS'Y	1	CW1684975	●
E21	SET SCREW	1	CW136116J	
E22	GROUNDING TIP (W/WASHER)	2	CW113783J	
E23	CUSHION RUBBER, SWITCH BOX	1	CW130707J	
E24	LATCH	1	CW0444491	
E25	WIRE HARNESS (FOR COMP.)	1	CW1684982	
E26	CLAMP, LEAD WIRE	1	CW1364156	
F1	BOTTOM FRAME ASS'Y	1	CW165694J	
F2	SIDE PLATE ASS'Y (RIGHT)	1	CW1684999	
F2-1	SIDE PLATE (RIGHT)	1	CW130728J	
F2-2	SOUND INSULATION (RIGHT)	1	CW1685000	
F2-3	SEALING MATERIAL (RIGHT SIDE)	1	CW1685017	
F3	FRONT PLATE ASS'Y	1	CW139741J	
F4	FRONT PLATE ASS'Y	1	CW1685024	
F5	PARTITION PLATE	1	CW1685031	
F6	MOTOR BASE	1	CW163127J	
F7	COVER, STOP VALVE	1	CW165665J	
F7-1	SOUND INSULATION (STOP VALVE)	1	CW1685048	
F7-2	SEALING MATERIAL	1	CW1685055	
F9	HANDLE	1	CW1379754	
F12	TAPPING SCREW	4	CW140380J	
F14	HEX. HEAD TAPPING SCREW	19	CW109224J	
F15	TRUSS HEAD TAPPING SCREW	17	CW008203J	
F17	TOP PLATE	1	CW118234J	
F18	SEALED BOARD ASS'Y	1	CW1685062	
F18-1	SEAL PLATE	1	CW137974J	
F18-2	SEALING MATERIAL	2	CW1437410	
F21	HOLE PROTECTION RUBBER	1	CW144136J	
K1	NAME PLATE	1	CW1685079	
K2	DRAIN JOINT	1	CW0589565	
K3	SCREW KIT	1	CW136424J	
K4	COLLECTIVE INDICATIONS LABEL	1	CW1685086	
K5	OPERATION NAME PLATE	1	CW1387793	
K6	CAUTION LABEL	1	CWF734916	
K7	INDICATION LABEL (TERMINAL)	1	CW1685093	
K8	BADGE	1	CW1685101	
K9	NAME PLATE	1	CW1685118	
K11	OPERATION MANUAL ASS'Y	1	CWF565237	
K12	OPERATION MANUAL ASS'Y	1	CWF565238	
K13	INSTALLATION MANUAL (OUTDOOR UNIT)	1	CWF612778	
K14	INSTALLATION MANUAL (OUTDOOR UNIT)	1	CWF612779	
K15	INSTALLATION MANUAL (OUTDOOR UNIT)	1	CWF612780	
K16	INSTALLATION MANUAL (CELLING FLOOR TYPE)	1	CWF612822	
K17	INSTALLATION MANUAL (CELLING FLOOR TYPE)	1	CWF612823	
K18	INSTALLATION MANUAL (CELLING FLOOR TYPE)	1	CWF612824	
K19	INSTALLATION MANUAL (MINI-CASSETTE)	1	CWF612825	
K20	INSTALLATION MANUAL (MINI-CASSETTE)	1	CWF612826	
K21	INSTALLATION MANUAL (MINI-CASSETTE)	1	CWF612827	
K22	INSTALLATION MANUAL (WALL TYPE)	1	CWF612819	
K23	INSTALLATION MANUAL (WALL TYPE)	1	CWF612820	
K24	INSTALLATION MANUAL (WALL TYPE)	1	CWF612821	
K25	INSTALLATION MANUAL (WALL TYPE)	1	CWF612816	
K26	INSTALLATION MANUAL (WALL TYPE)	1	CWF612817	
K27	INSTALLATION MANUAL (WALL TYPE)	1	CWF612818	

(Note)

- Parts other the operation manual and installation manual are parts for RoHS.
- “●” marked parts are recommended to be kept in stock.