

JBL

CS Series 200.1

1 CHANNEL POWER AMPLIFIER

SERVICE MANUAL



JBL Consumer Products
250 Crossways Park Dr.
Woodbury, New York 11797

Rev0 3/2004

- CONTENTS -

SPECIFICATIONS	1
CONNECTIONS.....	2
CONTROLS	3
BASIC TROUBLESHOOTING.....	3
EXPLODED VIEW/PARTS LIST.....	4
AMPLIFIER BLOCK DIAGRAM.....	5
P.C.B. DRAWINGS.....	6
ELECTRICAL PARTS LIST	8
IC/TRANSISTOR PINOUTS.....	11
SCHEMATICS.....	12
PACKING.....	15

CS200.1 Specifications

Output Power:	236W RMS x 1 channel @ 4 ohms, $\leq 1\%$ THD + N
(14.4V supply)	338W RMS x 1 channel @ 2 ohms, $\leq 1\%$ THD + N
Signal-to-noise ratio:	100dBA (reference 1W into 4 ohms)
Dynamic power:	464W @ 2 ohms
Effective damping factor:	6.395 @ 4 ohms
Frequency response:	10Hz – 320Hz (–3dB)
Maximum input signal:	7.5V
Maximum sensitivity:	260mV
Bass boost (45Hz)	Variable 0 – 6dB
DC Offset	<30mV
Output regulation:	.073dB @ 4 ohms
Idle Current	0.71A
Input Impedance	20k Ω
Max Current Draw	23A @ 4 ohms
	42A @ 2 ohms
Dimensions:	12 x 10 x 2 1/4" (L x W x H)
	(305mm x 254mm x 57mm)
Fuses:	20A x 2

JBL continually strives to update and improve existing products, as well as create new ones. The specifications and details in this and related JBL publications are therefore subject to change without notice.

APPLICATIONS - CS200.1

The CS subwoofer amplifier is a single-channel amplifier. There are two sets of terminals to make it easy to connect multiple woofers. Either set of (+/-) terminals may be used when connecting woofers.

To the right are two application diagrams to help plan your subwoofer system installation. **Figures 2 and 3** show how to configure the CS200.1 subwoofer amplifier.

NOTE: For simplicity, Figures 2 and 3 do not show power, remote and input connections.

NOTE: Minimum speaker load is 2 ohms total.

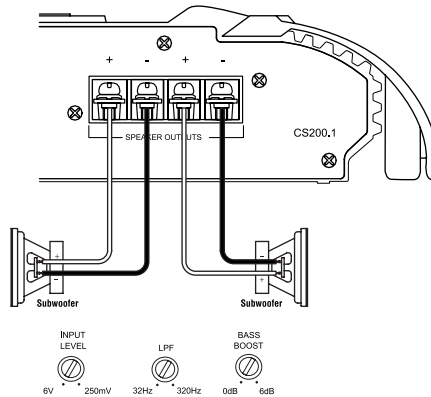

Figure 2. CS subwoofer amplifier with two woofers connected.

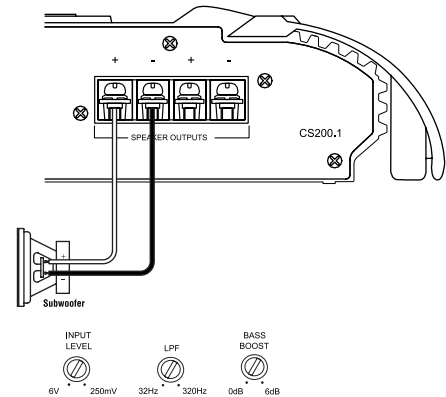

Figure 3. CS subwoofer amplifier with one woofer connected.

APPLICATIONS - CS50.4

The CS50.4 can be set up for stereo 4-channel, 3-channel or bridged 2-channel operation, as shown in **Figures 4 through 6**.

NOTE: For simplicity, Figures 4 through 6 do not show power, remote and input connections.

NOTE: Minimum speaker impedance for stereo operation is 2 ohms. Minimum speaker impedance for bridged operation is 4 ohms.

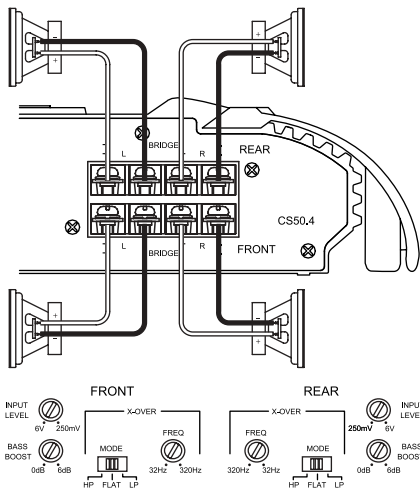

Figure 4. CS50.4 amplifier in 4-channel (stereo) operation to drive front and rear full-range speakers.

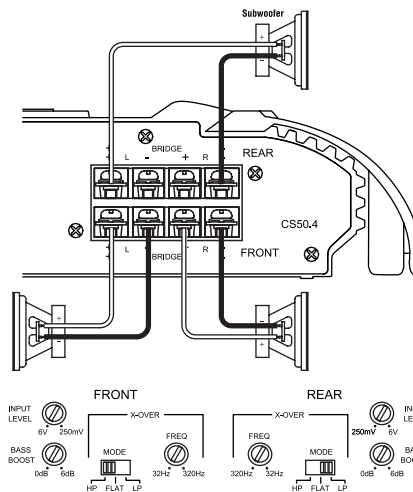

Figure 5. CS50.4 is set up for 3-channel operation to drive a set of full-range speakers and a subwoofer.

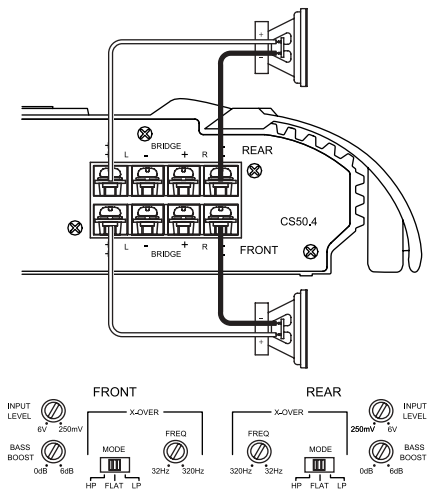

Figure 6.

CONTROLS AND SETUP

SETTING THE CROSSOVER(S)

Determine your system plans and set the crossover mode switch accordingly. If your system design does not include a subwoofer with the CS50.4, set the crossover mode to FLAT and skip to "Setting Input Sensitivity."

Initially set the crossover frequency control midway. While listening to music, adjust the crossover for the least perceived distortion from the speakers, allowing them to reproduce as much bass as possible.

Systems using a separate subwoofer set the crossover mode to HP (high pass) for your full-range speakers. Adjust the crossover frequency to limit bass and provide increased system volume with less distortion.

For subwoofers, choose the highest frequency that removes vocal information from the sound of the subwoofer.

If using the CS50.4 to drive a subwoofer(s), set the crossover mode to LP (low pass).

SETTING INPUT SENSITIVITY

1. Initially turn the INPUT LEVEL control(s) to minimum (counter clockwise).
2. Reconnect the (-) negative lead to the vehicle's battery. Apply power to the audio system and play a dynamic music track.
3. On the source unit, increase the volume control to 3/4 volume. Slowly increase the INPUT LEVEL control(s) toward three o'clock until you hear slight distortion in the music. Then reduce the INPUT LEVEL slightly until distortion is no longer heard.

NOTE: After the source unit is on, blue LEDs (on the top panel) will light, indicating the amplifier is on. If not, check the wiring, especially the remote connection from the source unit. Also refer to "Troubleshooting" guide below.

TROUBLESHOOTING

SYMPTOM	LIKELY CAUSE	SOLUTION	SYMPTOM	LIKELY CAUSE	SOLUTION
No audio (POWER LEDs are off)	No voltage at BATT+ or REM terminals, or no ground connection	Check voltages at amplifier terminals with VOM	No audio (POWER LEDs flash)	Voltage less than 9V on BATT+ connection	Check vehicle charging system
No audio (POWER LEDs are on)	Amplifier is overheated	Make sure amplifier cooling is not blocked at mounting location; verify speaker-system impedance is within specified limits	Distorted audio	DC voltage on amplifier output	Amplifier may need service; see enclosed warranty card for service information
	Voltage more than 16V or less than 8.5V on BATT+ connection	Check vehicle charging system	Distorted audio and POWER LEDs flash	Input sensitivity is not set properly, or amplifier or source unit is defective	Check INPUT LEVEL setting; or check speaker wires for shorts or grounds
			Music lacks "punch"	Short circuit in speaker or wire	Remove speaker leads one at a time to locate shorted speaker or wire, then repair
				Speakers are not connected properly	Check speaker connections for proper polarity

Features, specifications and appearance are subject to change without notice.

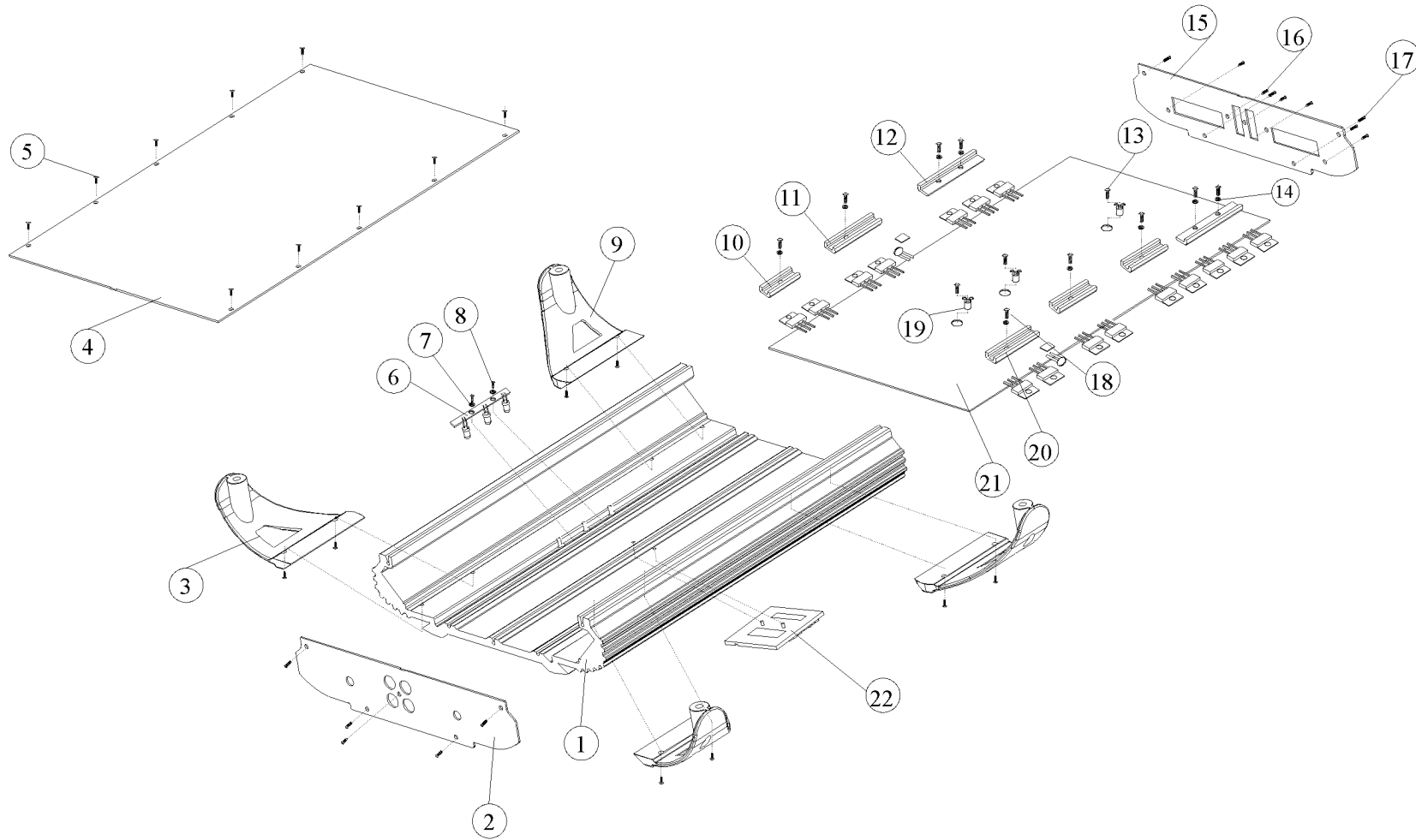

Item	Part No	Part name	Qty
22	819TJBL00	BADGE	1
21	025CS2001	PCB	1
20	621B25050A	PLATE	1
19	852T00005	PLASTIC STAND	3
18	711T14426	SCREW	9
17	721T53085	SCREW	8
16	721T33085	SCREW	6
15	674CS2001	RP	1
14	761T04001	Spring Washer	9
13	621T53125	SCREW	3
12	622B25060A	PLATE	2
11	621B25048A	PLATE	1
10	621B25038A	PLATE	3
9	657TJBL0R	R-CONNER BADGE	2
8	721T26065	SCREW	2
7	830T03010	WASHER	2
6	021TCSLED	LED PCB	1
5	725T50304	SCREW	10
4	695TCS504	BP	1
3	657TJBL0L	R-CONNER BADGE	2
2	680CS2001	FP	1
1	647CS2001	HS	1

Block Diagram CS200.1

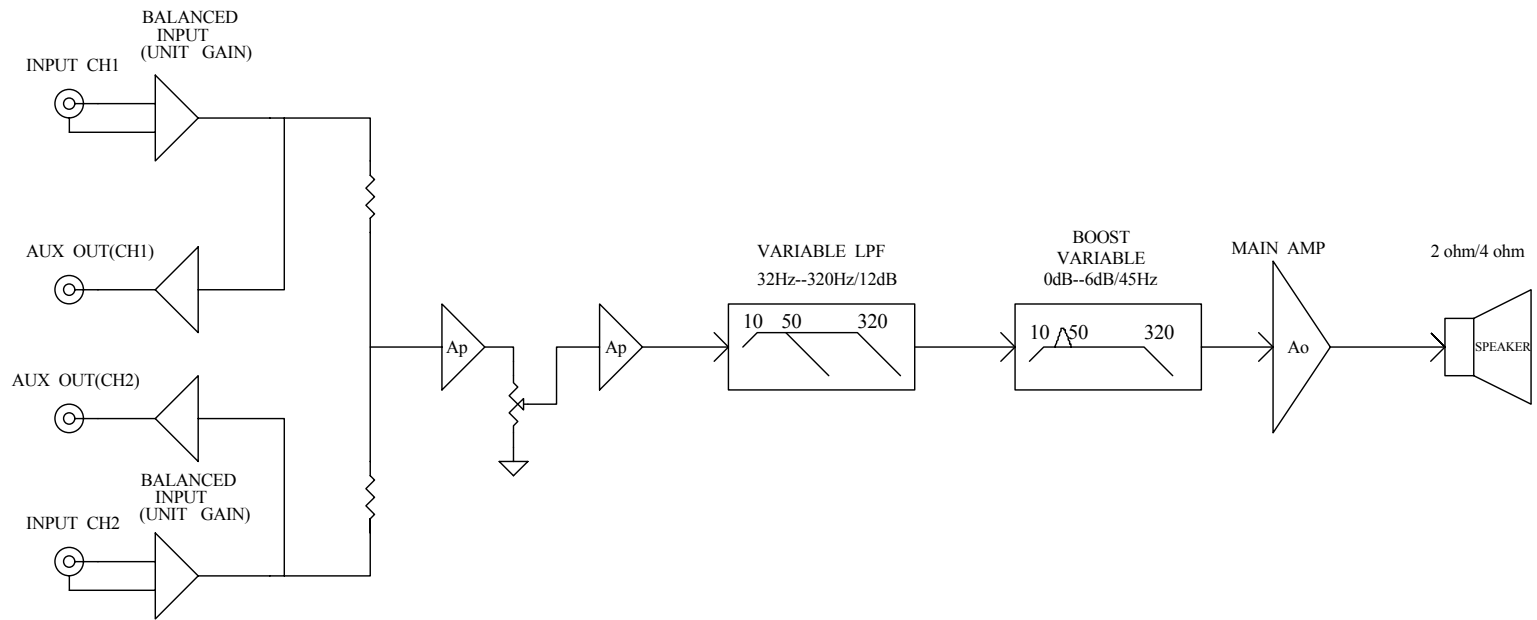

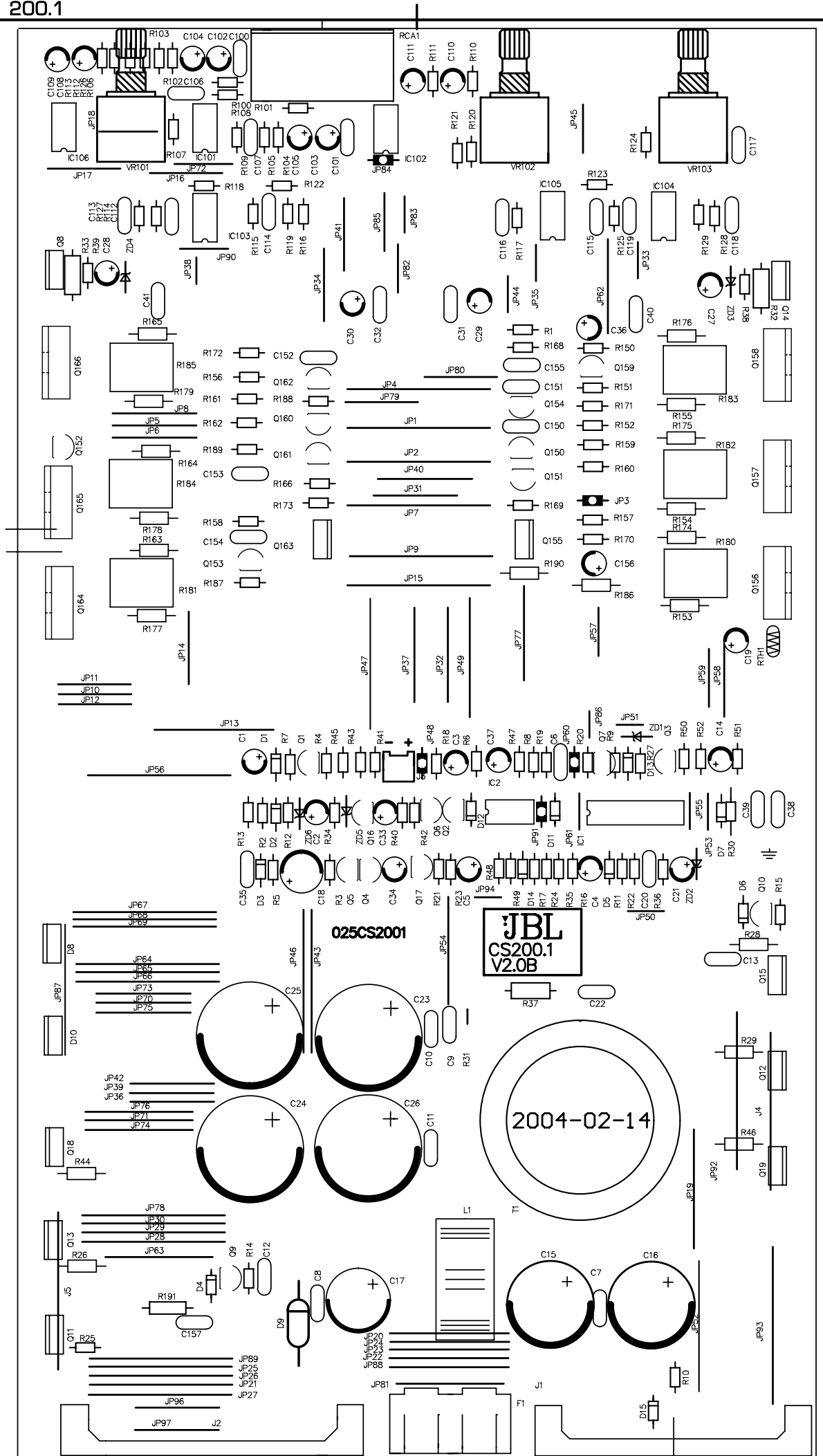

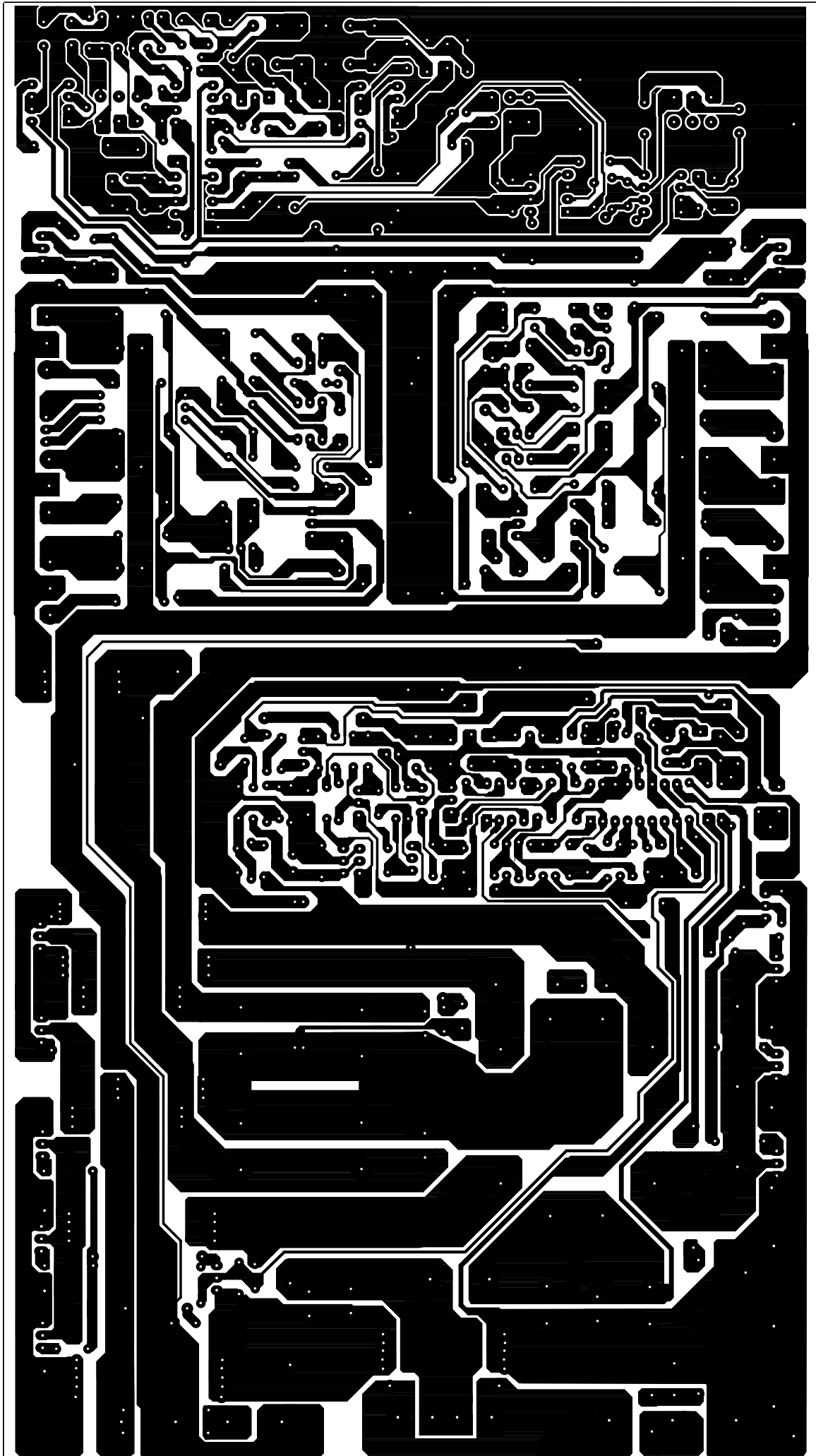

CS 200.1 Electrical Parts List

Part Number	Description		Qty	Reference Designator
Main PCB				
<i>Semiconductors</i>				
123T0K30A	Transistor	K30A	1	Q1
124TN4401	Transistor	TR MOTOROLA 2N4401	5	Q2 Q4 Q5 Q16 Q17
124TN4403	Transistor	TR MOTOROLA 2N4403	3	Q6 Q9 Q10
124TN5401	Transistor	TR MOTOROLA 2N5401	2	Q160 Q161
124TN5551	Transistor	2N5551	2	Q150 Q151
124T0SA06	Transistor	TRMOTOROLAMPSA06 80V	1	Q162
124T0SA42	Transistor	TR MOTOROLA MPSA42	1	Q153
124T0SA56	Transistor	TRMOTOROLAMPSA56 80V	1	Q154
125T0C945	Transistor	TR NEC 2SC945P 0.1A60V	1	Q159
126TSB647	Transistor	2SB647A	1	Q7
131TN4148	Diode	DIODE NS1N4148HSS150MA	11	D1~D7 D11 D12 D13 D15
133T0J5B6	Diode	DIODENECRD5.6JSB ZNR5.6V	1	ZD1
133T0011B	Diode	DIODE NEC RD11EB3 11V	1	ZD2
133T0015B	Diode	DIODE NEC RD15EB3 15V	2	ZD3 ZD4
133T0018B	Diode	DIODE NEC ZNR0.5W18V	1	ZD5
154TTL431	IC DIP3	TL431	1	Q3
124T0SA06	Transistor	TRMOTOROLAMPSA06 80V	1	Q152
128TTI41C	Transistor	TIP41C	1	Q155
128TTI42C	Transistor	TIP42C	1	Q163
134TN5402	Diode	DIODE 1N5402 ET3.0A100V	1	D9
154LM358N	IC DIP8	CHINALM358N	1	IC2
154T04558	IC DIP8	ROHM BA4558	6	IC101 IC102 IC103 IC104 IC105 IC106
158TTL494	IC DIP16	NEC UPC494 OR TI TL494	1	IC1
123TRFZ4N	Transistor	IR IRFZ46N	6	Q11 Q12 Q13 Q15 Q18 Q19
128TTI41C	Transistor	TIP41C	1	Q14
128TTI42C	Transistor	TIP42C	1	Q8
128TTI35C	Transistor	TR SGS OR TITIP35C N 25	3	Q156 Q157 Q158
128TTI36C	Transistor	TR SGS OR TITIP36C P 25A	3	Q164 Q165 Q166
135T1620C	Diode	DIODE MOTOROLA 1620CT	1	D8
135T1620R	Diode	DIODE MOTOROLA 1620CTR	1	D10
<i>Resistors</i>				
22022047A	Resistor	RD 1/2W 4.7Ω	1	R191
220220470	Resistor	RD 1/2W 47Ω	2	R32 R33
220440101	Resistor	RD 1/4W 100Ω	8	R163~165 R26 R44 R46 R28 R29
220440102	Resistor	RD 1/4W 1K	3	R153~155
220440221	Resistor	RD 1/4W 220Ω	1	R190
220440272	Resistor	RD 1/4W 2.7K	1	R186
22044047A	Resistor	RD 1/4W 4.7Ω	6	R174~R179
220880000	Resistor	RD 1/8W 0Ω	7	JP3 JP48 JP60 JP84 JP91 D14 R21
220880101	Resistor	RD 1/8W 100Ω	6	R25 R27 R159~R162
220880102	Resistor	RD 1/8W 1K	13	R7 R11 R14-15 R40-41 R112-113 R123 R156 R158 R151 R152
220880103	Resistor	RD 1/8W 10K	9	R10 R115~R118 R166 R169 R188 R20
220880104	Resistor	RD 1/8W 100K	5	R2 R3 R12 R110 R111
220880123	Resistor	RD 1/8W 12K	1	R17
220880153	Resistor	RD 1/8W 15K	2	R49 R52
220880154	Resistor	RD 1/8W 150K	2	R42 R43
220880183	Resistor	RD 1/8W 18K	1	R35
220880202	Resistor	RD 1/8W 2K	1	R5
220880203	Resistor	RD 1/8W 20K	1	R1
220880204	Resistor	RD 1/8W 200K	1	R23
220880205	Resistor	RD 1/8W 2M	1	R22
220880222	Resistor	RD 1/8W 2.2K	1	R36
220880223	Resistor	RD 1/8W 22K	2	R45 R119
220880223L	Resistor	RD 1/8W 22K 52MM	1	R30

Part Number	Description		Qty	Reference Designator
220880242	Resistor	RD 1/8W 2.4K	2	R24 R189
220880302	Resistor	RD 1/8W 3K	5	R18 R38 R39 R150 R9
220880362	Resistor	RD 1/8W 3.6K	2	R124 R187
220880363	Resistor	RD 1/8W 36K	1	R50
220880392	Resistor	RD 1/8W 3.9K	2	R129 R13
220880470	Resistor	RD 1/8W 47Ω	2	R171 R172
220880472	Resistor	RD 1/8W 4.7K	2	R173 R168
220880473	Resistor	RD 1/8W 47K	5	R34 R102~R105
220880474	Resistor	RD 1/8W 470K	2	R4 R128
220880562	Resistor	RD 1/8W 5.6K	3	R120 R121 R125
220880563	Resistor	RD 1/8W 56K	5	R106 R107 R108 R109 R51
220880682	Resistor	RD 1/8W 6.8K	2	R16 R122
220880751	Resistor	RD 1/8W 750Ω	1	R126
220880913	Resistor	RD 1/8W 91K	2	R100 R101
230881001	Resistor	MF 1/8W 1K 1%	1	R157
230881002	Resistor	MF 1/8W 10K 1%	2	R19 R47
230881003	Resistor	MF 1/8W 100K 1%	1	R114
230881052	Resistor	MF 1/8W 10.5K 1%	1	R6
230882202	Resistor	MF 1/8W 22K 1%	1	R8
230885601	Resistor	MF 1/8W 5.6K 1%	1	R127
230886191	Resistor	MF 1/8W 6.19K 1%	1	R170
202G15B23	VR	B20K	2	VR101 VR103
202T15C52	VR	C50K	1	VR102
231100100	Resistor	1Ws 10Ω	1	R31
231100220	Resistor	1Ws 22Ω	1	R37
23251002A	Resistor	SQM 5W 0.2Ω (□□)	6	R180 R181 R182 R183 R184 R185
261T05103	Thermistor	NTC THERMISTORD103J 10K	1	RTH1
<i>Capacitors</i>				
31J510110	Capacitor	C/C NPO 100PF/100V J	5	C106 C107 C113 C114 C155
31K510210	Capacitor	C/C 1000PF/100V K	2	C100 C101
31Z510305	Capacitor	C/C Y5V 10000P/50V Z	1	C35
31Z510410	Capacitor	C/C Y5V 0.1UF/100V Z	8	C6 C7 C8 C9 C10 C11 C31 C32
31J522010	Capacitor	C/C NPO 22PF/100V J	1	C112
31J522110	Capacitor	C/C NPO 220PF/100V	2	C12 C13
31J547010	Capacitor	C/C NPO 47PF/100V J	3	C150 C151 C152
31K547110	Capacitor	C/C Y5E470PF/100V K	1	C119
31K547310	Capacitor	C/C 0.047UF/100V K	2	C38 C39
31J568125	Capacitor	C/C Y5E 680P/250V K	1	C22
32J510410	Capacitor	M/C 0.1UF/100V J	1	C157
32J518410	Capacitor	M/C 0.18uf/100V J	1	C117
32J539310	Capacitor	M/C 0.039UF/100V J	1	C118
32J568210	Capacitor	M/C 0.0068uf/100V J	1	C20
32J582310	Capacitor	M/C 0.082 UF/100V J	2	C115 C116
340Z10650	Capacitor	10UF/50V 5*11	3	C110 C111 C36
340Z10716	Capacitor	100U/16V 5*11	5	C4 C19 C27 C28 C156
340Z22550	Capacitor	2.2UF/50V 5*11	2	C33 C34
340Z22625	Capacitor	22UF/25V 5*11	8	C2 C103 C105 C21 C102 C104 C108 C109
340Z47550	Capacitor	4.7U/50V 5*11	1	C3
340Z47625	Capacitor	47UF/25V 5*11	3	C5 C14 C37
344Z22716	Capacitor	220UF/16V 6.3*12	2	C29 C30
370Z10550	Capacitor	1UF/50V 5*11	1	C154
370Z10716	Capacitor	100UF/16V 8*12	1	C18
370Z22616	Capacitor	22UF/16V NP	1	C1
391T10104	Capacitor	(BOX) 0.1U/100V MEMB	1	C153
391T10474	Capacitor	(BOX) 0.47U/100V J MEMB	2	C40 C41
341T22835	Capacitor	2200UF/35V 16*26 105C	3	C15 C16 C17
341T22863	Capacitor	2200UF/63V 22*27R 105C	4	C23 C24 C25 C26

Part Number	Description		Qty	Reference Designator
<i>Miscellaneous</i>				
571T20070	Wire	1015# 20AWG 70MM	1	GND
172T41026	Coil	T23*90-26 1.2*5 2.6uH	1	L1
181T37621	Transformer	37φ6:21 F=1.2*3*6 S=1.2*2*21	1	T1
435T00020	Fuse	20A ATC	2	F1
447T00001	Fuse Holder	PCB Fuse holder	1	F1
524TRC04S	RCA Jack	RCA Jack	1	RCA1
535T25002	Connector	2P P=2.5MM 9	1	J3
541T34304	Terminal	HD-343 4Pin 3.4	1	J2
544T300003	Terminal	GA30-03-3Pin	1	J1
137T05B02	LED	5ψLED Blue	3	BLED1~3
647CS2001	Heat sink	CS200.1 L=300	1	
674CS2001	Rear panel	CS200.1	1	
680CS2001	Front panel	CS200.1	1	

Semiconductor Pinouts

LM358 Dual Op-Amp
4558 Dual Op-Amp

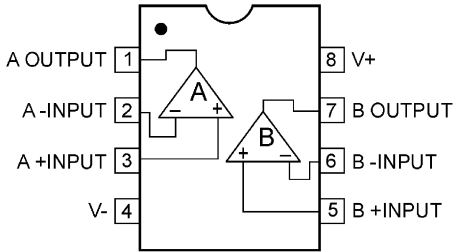

TL494 PWM

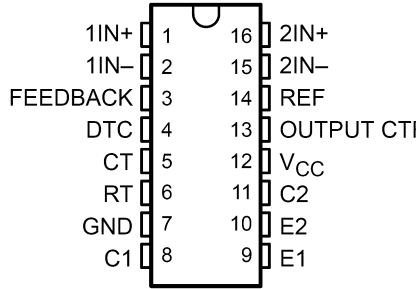

TIP41C, TIP42C

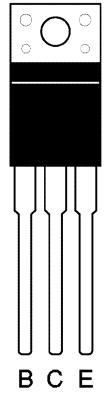

IRFZ46N
MOSFET

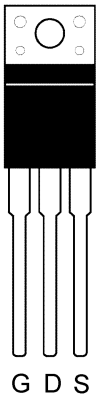

TIP35C, TIP36C

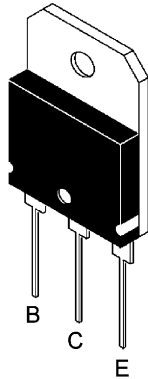

FET
2SK30ATM

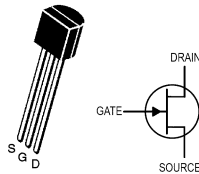

2SB647A

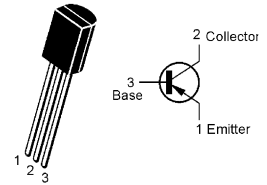

2N5401
2N4403
MPSA56

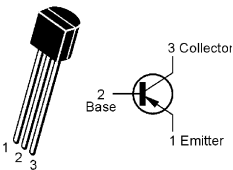

2N5551
2N4401
MPSA06
MPSA42

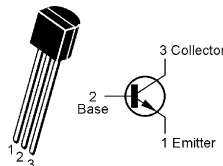

2SC945P

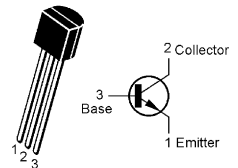

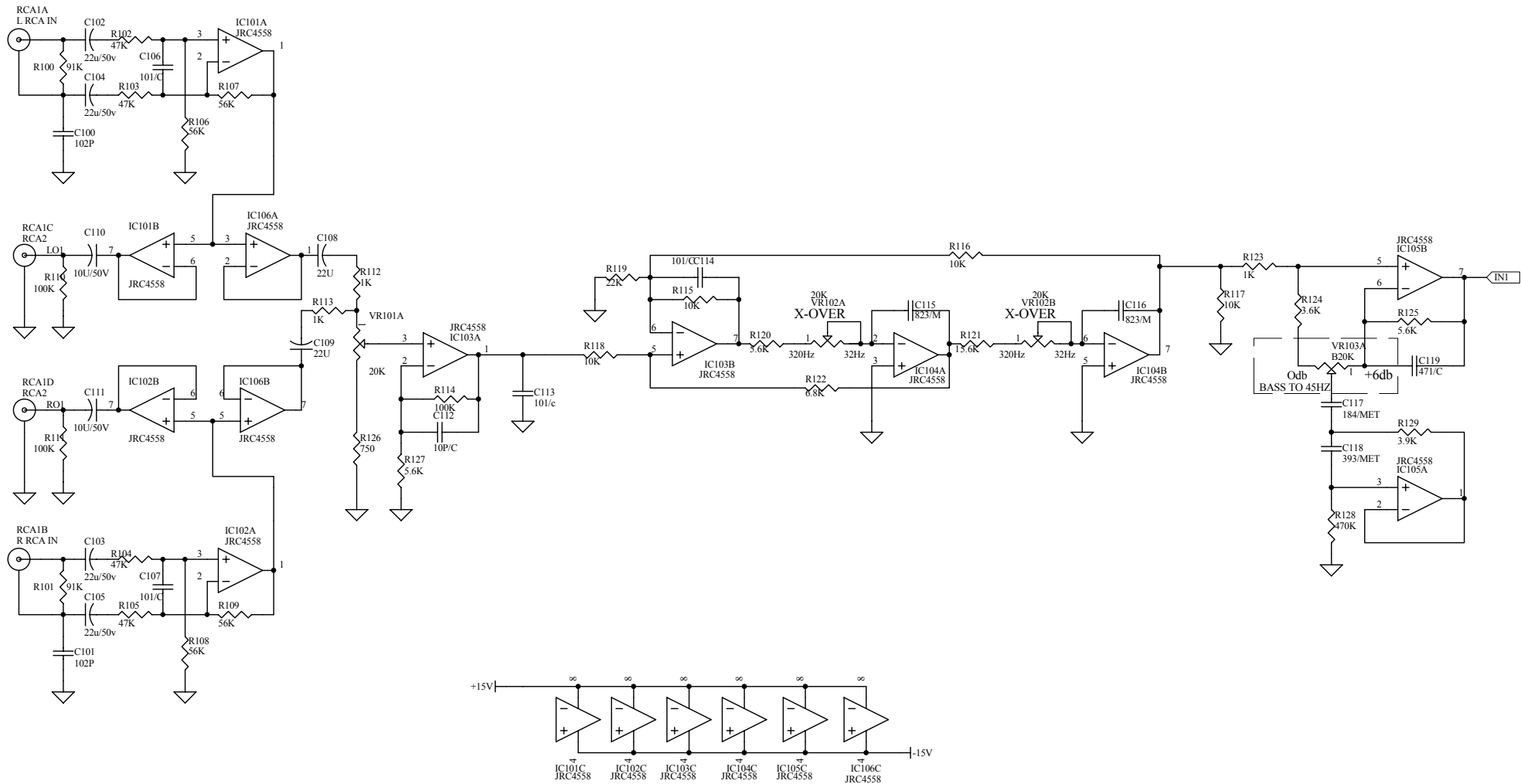

TITLE:		JBL CS200.1		
DRAWN: CZJ	DATE: 03/18/2004	CHECKED:	DATE:	APPROVED:
DWG NO: PT-1-B042-01-A1	REV: 2.0B	SHEET: 1/3		

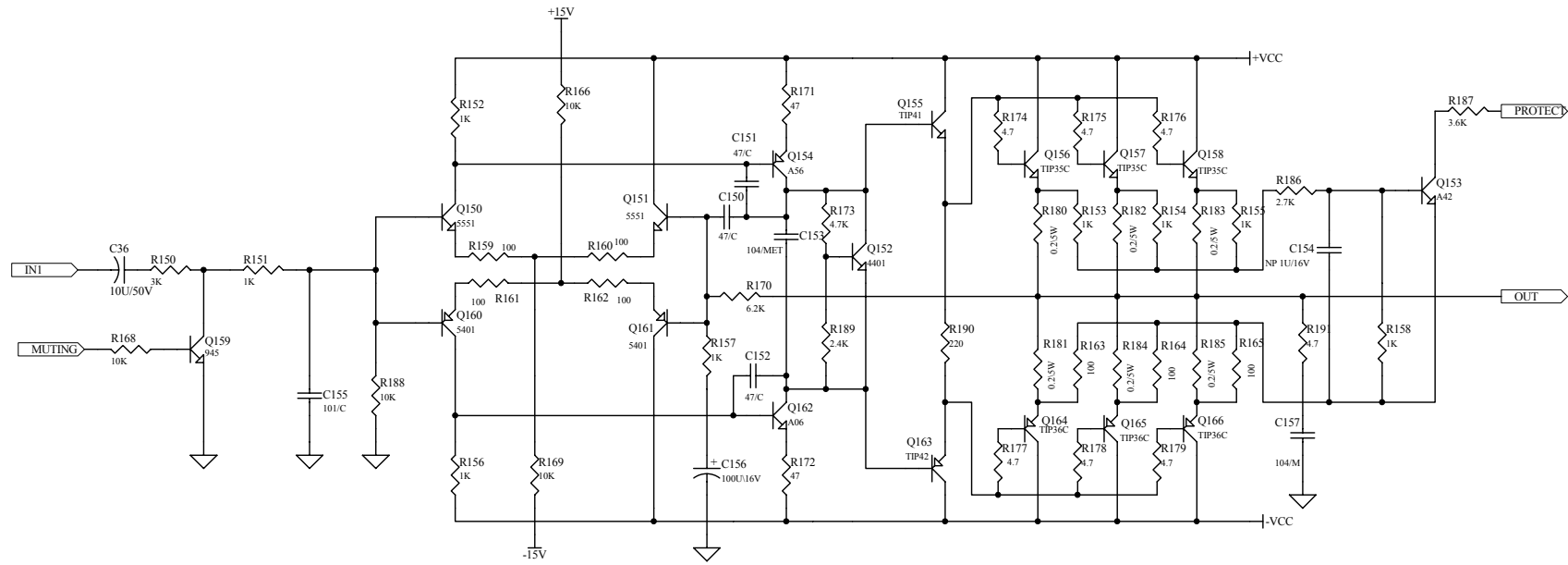

TITLE:		JBL CS200.1		
DRAWN:	DATE:	CHECKED:	DATE:	APPROVED:
CZJ	03/18/2004			
DWG NO:	PT-1-B042-01-A1	REV: 2.0B	SHEET:	2/3

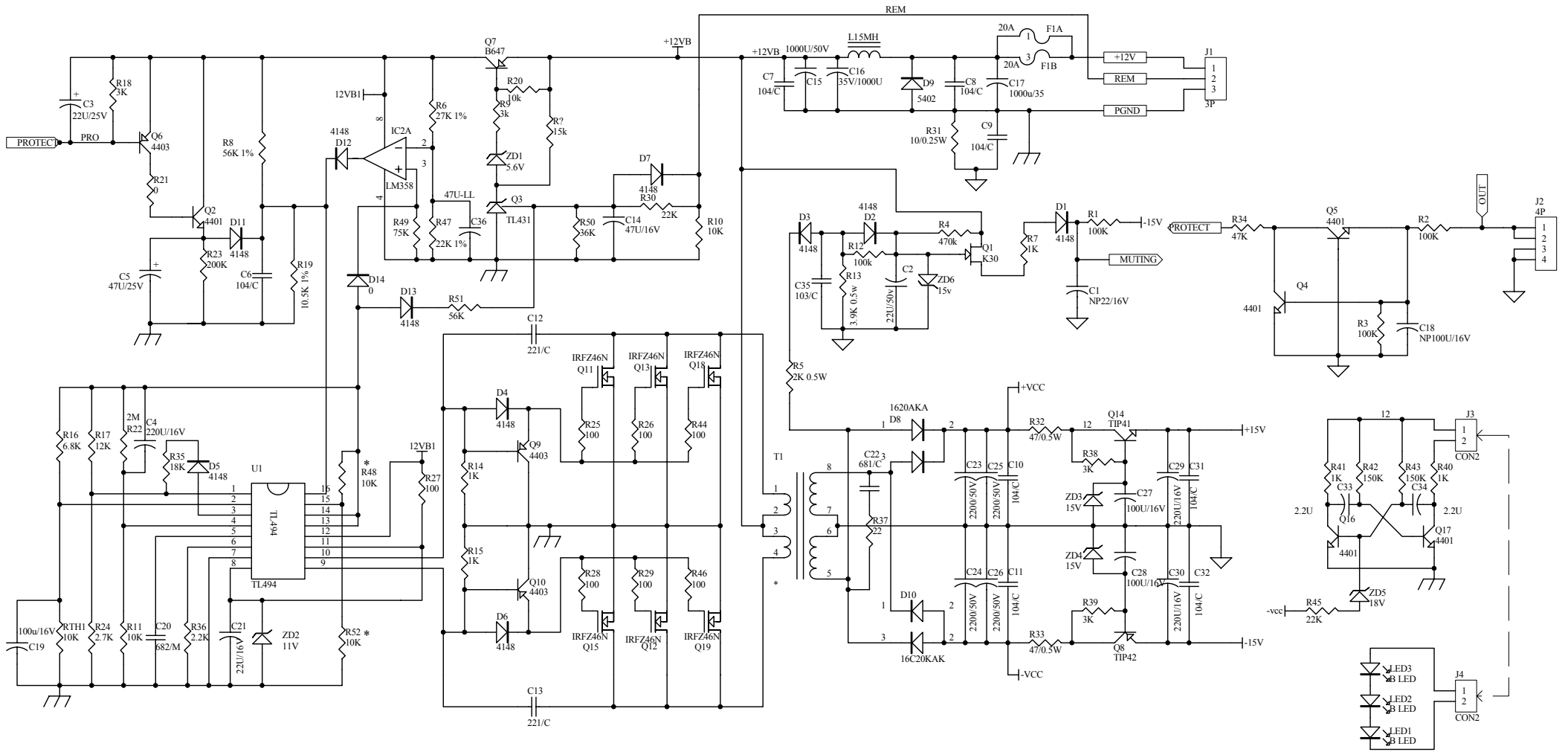

TITLE:		JBL CS200.1		
DRAWN:	DATE:	CHECKED:	DATE:	APPROVED:
CZJ	03/18/2004			
DWG NO:	PT-1-B042-01-A1	REV: V2.0B	SHEET:	3/3

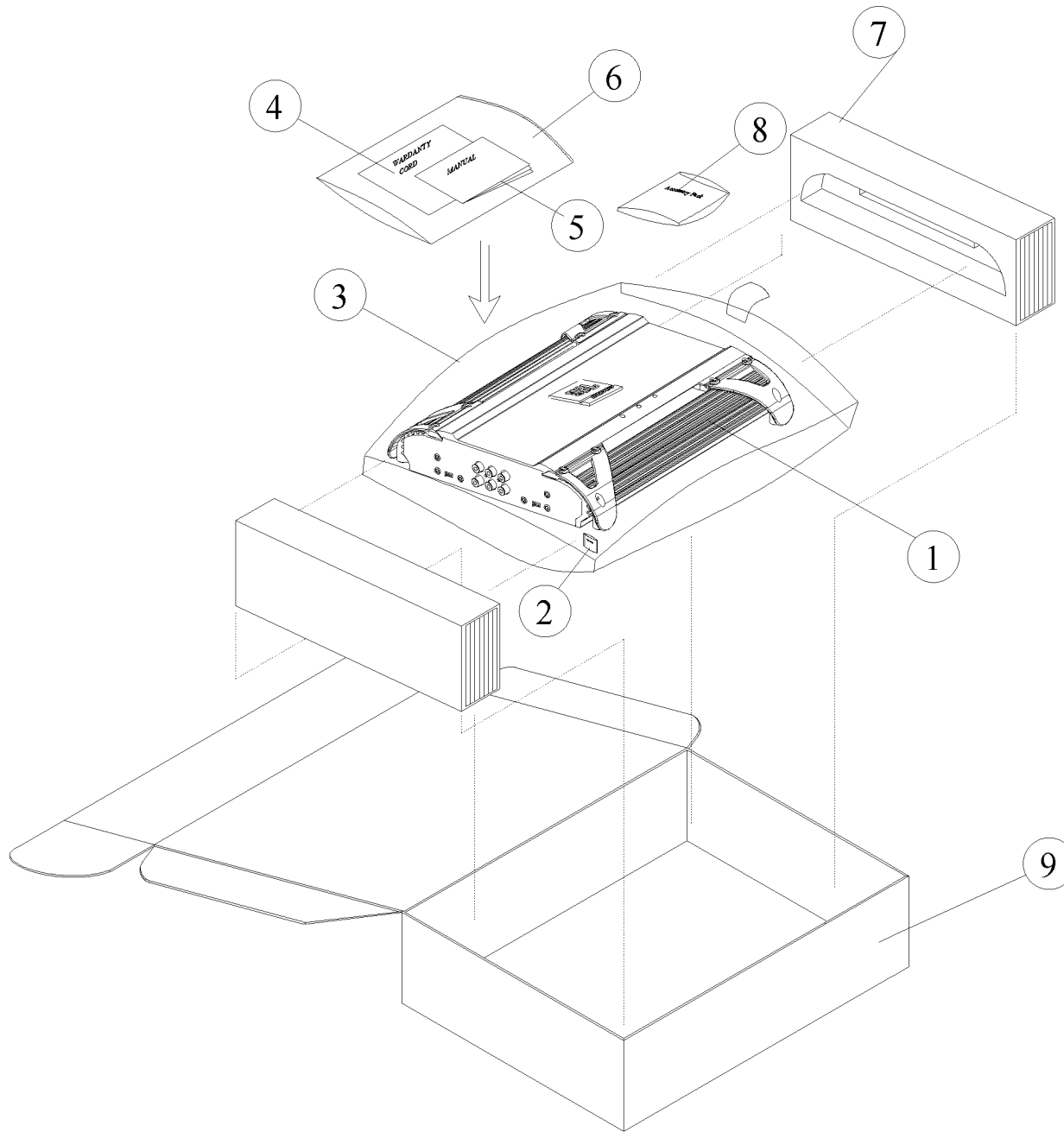

Item	Part No	Part name	Qty
⑨	947TCS201	Outer Carton	1
⑧	CS200.1-08	Accessory Pack	1
⑦	CS200.1-07	End Pads	2
⑥	CS200.1-06	SMALL BAG	1
⑤	CS200.1-05	MANUAL	1
④	CS200.1-04	Warranty Card	1
③	872Y81319	BAG	1
②	999T20002	desiccant	1
①		AMP	1